



PF3100

FARC User Guide

DOC-001065 v8.0

PROFIRE

CONTENTS

1	IMPORTANT SAFETY INFORMATION	3
2	DOCUMENT SCOPE	4
	Applicable Firmware Versions	4
	Additional Documentation	4
3	HARDWARE REQUIREMENTS	5
	PF3100 Components	5
	Peripheral Equipment Requirements	6
4	INSTALLATION	7
5	FARC AND O₂ TRIM TERMINOLOGY	8
	FARC Channels	8
	FARC Table	8
	Leading vs. Lagging Channels	9
	Channel Limitations	9
	O ₂ Trim	10
	Table Configuration	10
	O ₂ Sensor Warmup	11
	O ₂ Trim PI Controller	11
	Operating Sequence.....	12
	Position Monitoring.....	13
	Cross Limiting.....	13
	System Firing Rate vs. Effective Firing Rate.....	13
	Flat Line Tolerance	13
	Cross Limiting Examples	14
6	COMMISSIONING	16
	FARC Configuration Procedure	16
	Create and Assign FARC Inputs and Outputs.....	16
	Configure General FARC settings	17
	Calibrate Outputs	19
	Tune System for stable Pilot Light Off	20
	Configure FARC Table at the Light Off Firing Rate.....	21
	Configure FARC Table at the Minimum Firing Rate	21
	Configure FARC Table at the Maximum Firing Rate	22
	Configure Fuel Channel across Entire Table	23
	Tune the FARC Table Between 5% and 95%	23
	Validate FARC Table	24
	O ₂ TRIM Configuration Procedure.....	25
	Set O ₂ Trim Parameters	25
7	TROUBLESHOOTING	26
8	CANADIAN FIELD APPROVAL REQUIREMENTS	28
9	VERSION HISTORY	31

1 IMPORTANT SAFETY INFORMATION



Warning: Do not disconnect power, open enclosures, or otherwise service the product unless area is known to be non-hazardous.



Warning: Installation and modification shall not be performed while the system is energized. Disconnect power source prior to connecting devices or modifying wiring.



Warning: System settings and appliance configuration details must only be modified by qualified personnel familiar with the both the appliance under PF3100 control and related plant processes that could be affected.



Warning: Do not bypass any of the safety functions or modify any of the internal circuitry of the system. Doing so can lead to death, serious injury, electrocution, property damage, product damage and/or government fines

The configuration examples provided in this guide are for demonstration purposes only and do not necessarily represent safe or reliable configurations. Installation, commissioning and tuning of a FARC system must be performed by a qualified technician with experience in commissioning and tuning forced draft positioning-type FARC systems in accordance with local safety codes, design documentation and appliance manufacturer specifications. Regular maintenance should be performed on the system to verify tuning and system operation.

2 DOCUMENT SCOPE

The Profire PF3100 combustion control system can be configured to operate as a parallel positioning fuel-air ratio control (FARC) system for forced draft applications requiring up to five control channels (fuel, air, and up to three auxiliary channels). The system allows specific output positions to be configured for each channel at 5% firing rate intervals across the entire operating range of the appliance. Channel feedback inputs are constantly monitored to ensure accurate positioning and outputs are adjusted to maintain precise ratio control in relation to all configured FARC channels. The system also supports single channel O₂ Trim to maintain desired stack oxygen readings and increase appliance efficiency. Desired stack oxygen levels can also be configured at 5% firing rate intervals across the entire operating range of the appliance.

This user guide contains a general overview of the PF3100 FARC system features, commissioning procedures and operation.

APPLICABLE FIRMWARE VERSIONS

The information provided in this document applies only to PF3100 systems configured for FARC applications running NA-43 firmware.

ADDITIONAL DOCUMENTATION

This document outlines information specific to FARC applications only. Visit the [Profire Documentation Website](#) to access additional PF3100 documentation.

3 HARDWARE REQUIREMENTS

The following sections specify the PF3100 components and peripheral equipment required to commission a FARC system with a PF3100. The items listed below do not include standard fuel train components required in accordance with local safety codes and heater manufacturer specifications.

PF3100 COMPONENTS

At a minimum, A PF3100 system configured for FARC applications must include: one PF3100-00 User Interface card, one PF3101-00 BMS Controller card, one PF3102-00 Ion Pilot card, one PF3103-00 Temperature card and one PF3113-00 I/O Expansion card. This will accommodate a single pilot FARC system controlling fuel and air position and up to 2 additional I/O Expansion inputs.

Additional Network cards, Pilot cards, temperature cards, and I/O Expansion cards can be added as required to accommodate more complex FARC applications in accordance with the diagram below:

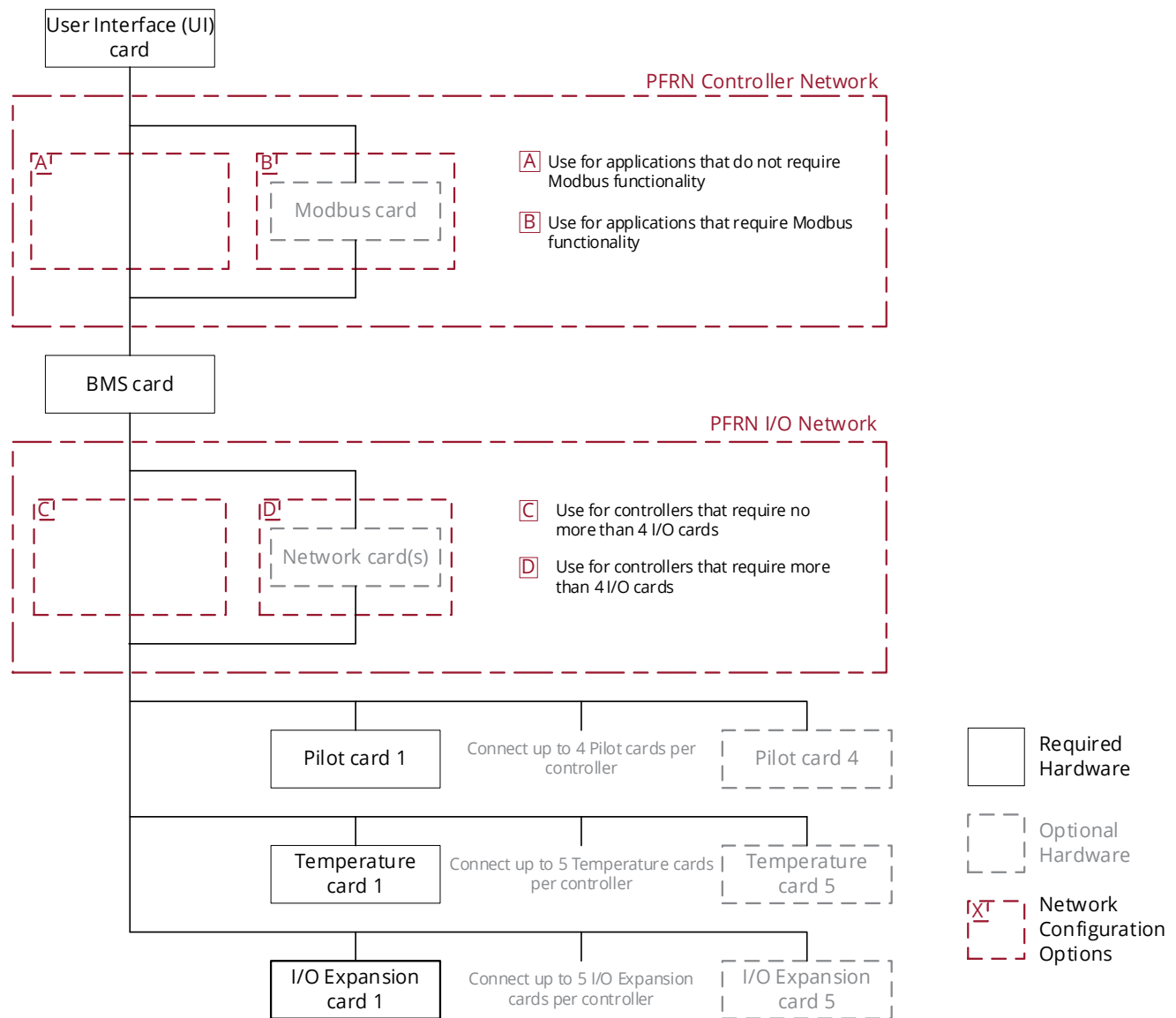

PERIPHERAL EQUIPMENT REQUIREMENTS

The following peripheral equipment is required to satisfy the input and output requirements of a PF3100 FARC system:

Item	Input Requirements	Output Requirements	Application Requirements
Fuel Gas Control Valve	Position must be controlled by a 4-20mA input signal.	Current position must be represented by a 4-20mA position feedback signal.	Required for all FARC applications
Air damper or VFD blower	Position/speed must be controlled by a 4-20mA input signal.	Current position/speed must be represented by a 4-20mA position feedback signal	Required for all FARC applications
Auxiliary FARC channel actuator	Position must be controlled by a 4-20mA input signal.	Current position must be represented by a 4-20mA position feedback signal only if the channel is to be used for cross limiting.	Required for FARC application with control channels beyond Fuel and Air.
Proof of Airflow device	N/A	Must be an airflow switch or 4-20mA transmitter.	Required for all FARC applications
Oxygen sensor	N/A	Must be a 4-20mA transmitter.	Required for FARC applications utilizing PF3100 O ₂ trim functionality.
Additional safety interlocks and sensors	N/A	Can be switches or 4-20mA transmitters and can be configured as alarms, waits, warnings or main permissives.	Can be added as required in accordance with local safety codes and heater manufacturer specifications.

4 INSTALLATION

The diagram below shows the expected configuration for all FARC inputs and outputs only. Refer to the [PF3100 Product Manual](#) for detailed installation instructions and wiring diagrams. Note that a single I/O Expansion card is required for basic FARC applications, but a network card and additional I/O Expansion cards are required for multichannel FARC applications or those requiring additional instrumentation.

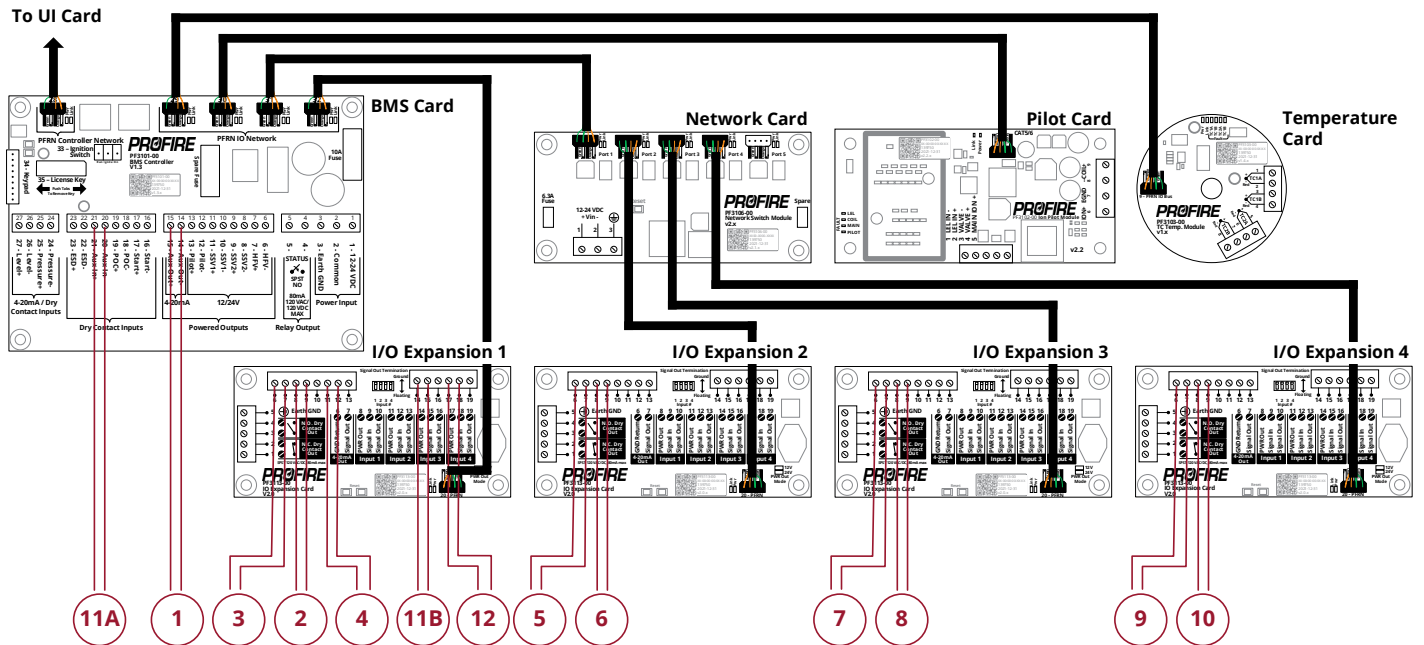

#	Input/Output	Signal Type	PF3100 Card / Terminal
1	Fuel actuator output	4-20mA output	BMS / Aux Out
2	Fuel position feedback input	4-20mA input	Any I/O Expansion card / Any available input
3	Air actuator output	4-20mA output	I/O Expansion 1 / 4-20mA Out
4	Air position feedback input	4-20mA input	Any I/O Expansion card / Any available input
5	Aux 1 channel output	4-20mA output	I/O Expansion 2 / 4-20mA Out
6	Aux 1 channel feedback input	4-20mA input	Any I/O Expansion card / Any available input
7	Aux 2 channel output	4-20mA output	I/O Expansion 3 / 4-20mA Out
8	Aux 2 channel feedback input	4-20mA input	Any I/O Expansion card / Any available input
9	Aux 3 channel output	4-20mA output	I/O Expansion 4 / 4-20mA Out
10	Aux 3 channel feedback input	4-20mA input	Any I/O Expansion card / Any available input
11A	Proof of Airflow input Option 1	Digital input	BMS / Aux In
11B	Proof of Airflow input Option 2	Digital or 4-20mA input	Any I/O Expansion card / Any available input
12	Oxygen sensor input	4-20mA input	Any I/O Expansion card / Any available input

5 FARC AND O₂ TRIM TERMINOLOGY

FARC CHANNELS

A FARC channel is a controller output for which precise position control is required over the operating range of an appliance.

FARC TABLE

The FARC Table specifies the output positions of each FARC channel at 5% firing rate intervals across the operating range of the appliance (21 configurable points for each channel). Each column represents a specific firing rate for the system and each row specifies the corresponding channel output position required at that firing rate.

Table View

Firing Rate	15	20	25	30	35	40	45	50	55	60	65	70	75	80	85	90
Fuel	19	22	25	28	31	34	37	40	43	46	49	52	55	58	61	64
Air	49	52	55	58	61	64	67	70	73	76	79	82	85	88	91	94
Aux 1	1	1	15	15	15	15	15	15	15	15	15	40	40	40	40	40
Aux 2	5	5	20	20	20	20	20	20	20	20	20	20	20	5	5	5

Curve View

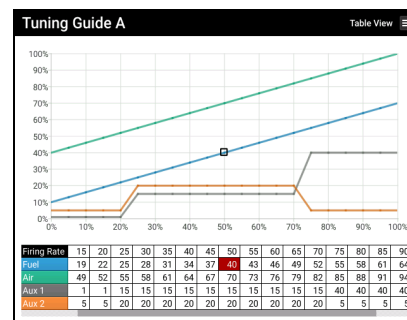

MANUAL MODE

The Manual Mode setting on the FARC Status Screen must be enabled to make any changes to the FARC Table. Manual Mode holds the system firing rate at the configured Manual Firing Rate setting during the Process Control state and must only be enabled during commissioning. A warning is displayed on the Alerts Screen when Manual Mode is enabled – ensure that Manual Mode is disabled when commissioning is complete.

ADJUSTING POINTS

Use **+** and **-** to incrementally adjust a configured point or press **OK** to access the numerical entry dialog.

ADDING POINTS

Press **OK** on an unconfigured point to activate its FARC Table column.

REMOVING POINTS

Press **DEL** on a configured point to de-activate its FARC Table column. Configured points in the deleted column are removed and replaced with interpolated values.

INTERPOLATION

Configured columns are shown in black, while unconfigured columns are shown in gray. A FARC Table with a single configured column remains flat (i.e., Every point in the table row matches the value in the configured column). Unconfigured points between configured points are linearly interpolated and treated as configured points.

CURVE SWITCHING

The system allows for two separate FARC curves to be configured to account for varying demand profiles. The curves can be switched by configuring the Selected Curve setting in the FARC/O₂ Trim Wizard or the FARC status screen. Note: If the Selected Curve setting is changed while the system is in a main fuel state the system remains running but first transitions out of the main fuel state to reinitiate the light off sequence with the new curve configuration.

LEADING VS. LAGGING CHANNELS

Leading channels are those that can increase above their expected positions without creating a dangerous fuel mixture. For this reason, leading channels always move before lagging channels upon firing rate increase and after lagging channels upon firing rate decrease ensuring that the leading channels are always in excess while transitioning. The air channel is a leading FARC channel, the fuel channel is a lagging FARC channel, and auxiliary channels can be configured as (1) leading, (2) lagging, or (3) neither.

CHANNEL LIMITATIONS

The curves for the fuel and air channels must not have any sections with a negative slope. The curves for leading or lagging auxiliary channels must have no inflection points. Auxiliary channels configured as neither a leading nor lagging channel have no slope and inflection point limitations.

Acceptable Cross Limited Auxiliary Channel Curves

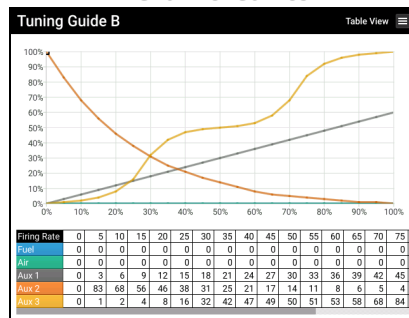

Unacceptable Cross Limited Auxiliary Channel Curves

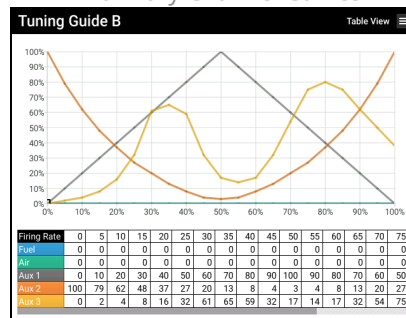

O₂ TRIM

O₂ Trim is designed to fine-tune either the fuel or air channel output to maintain appliance efficiency across a variety of environmental conditions without having to recommission the FARC Table.

TABLE CONFIGURATION

The Manual Mode setting on the O₂ Trim Status Screen must be enabled to make any changes to the O₂ Trim curves. Manual Mode holds both (1) the system firing rate at the configured Manual Firing Rate setting and (2) the Trim Offset at the configured Manual Offset setting during the Process Control state and must only be enabled during commissioning. A warning is displayed on the Alerts Screen when Manual Mode is enabled – ensure that Manual Mode is disabled when commissioning is complete.

TARGET O₂ CURVE

The Target O₂ curve specifies the optimal stack O₂ reading in 5% firing rate intervals across the entire operating range of the appliance. The Target O₂ values must be configured between the High and Low O₂ setpoints – they are displayed on the Target O₂ curve when in curve view. An O₂ reading below the Low Setpoint results in a Lockout, while an O₂ reading above the High Setpoint displays a warning on the Alerts Screen but has no effect on system operation. (Note: The lower boundary of the Target O₂ Trim curve is the higher of the configured Low O₂ Setpoint and 0.5%)

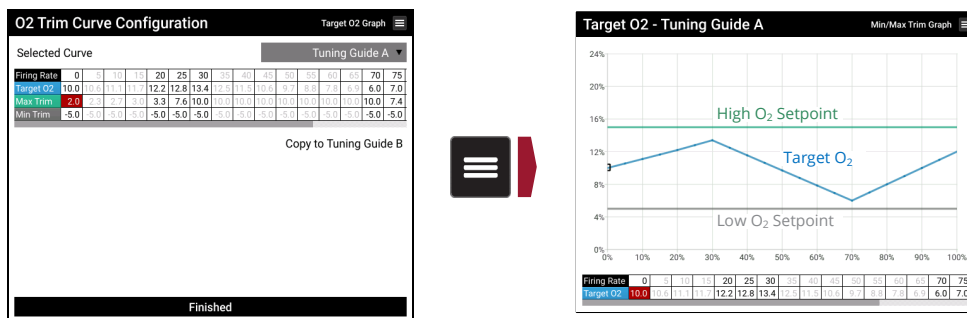

MAX/MIN TRIM CURVE (OFFSET CURVE)

The Max/Min Trim curve specifies the maximum and minimum offset percentage that can be applied to a FARC channel output (up to a maximum of +10% and a minimum of -10% as specified by the configured Trim Channel setting on the O₂ Trim Tab of the FARC/O₂ Trim Wizard) while trimming. The current applied O₂ Offset is displayed on the Status Screen (e.g., A displayed O₂ Offset of -3.5% means the system has decreased the trimmed channel output 3.5% below its configured FARC Table value).

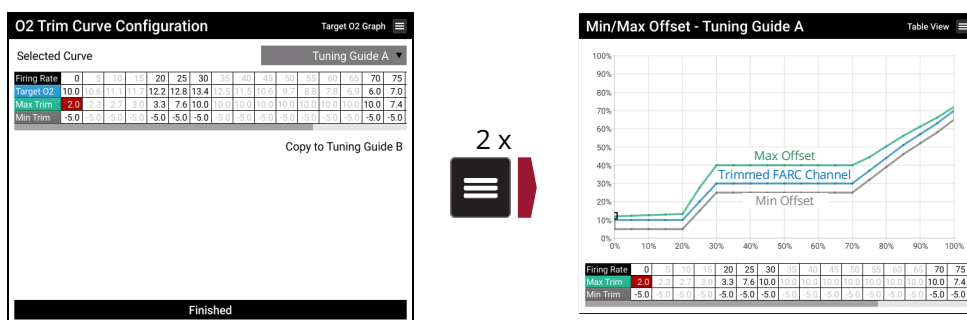

O₂ SENSOR WARMUP

Stack-heated O₂ sensors require the stack to be at a specific temperature before they can be relied upon for accurate readings while self-heating O₂ sensors do not rely on stack temperature. The configuration requirements for Warmup Mode and related settings on the FARC Wizard O₂ Trim Tab are dictated by the manufacturer recommendations for the type of sensor used.

Stack-heated sensor configuration

FARC Wizard (H-4 FARC Heater)	
General	O ₂ Trim
Trim Channel	Fuel
Low O ₂ Setpoint	0.0 %
High O ₂ Setpoint	15.0 %
O ₂ Deadband	1.0 %
O ₂ Sensor Warmup Mode	Stack Temp
Stack Temperature Input	TE-402 Stack
Minimum Stack Temperature	100 °C
Stack Temperature Deadband	2 °C
O ₂ Proportional Band	500.0
O ₂ Integral Time	10.0 min
System Delay Time	10 sec

Self-heating sensor configuration

FARC Wizard (H-4 FARC Heater)	
General	O ₂ Trim
Trim Channel	Fuel
Low O ₂ Setpoint	0.0 %
High O ₂ Setpoint	15.0 %
O ₂ Deadband	1.0 %
O ₂ Sensor Warmup Mode	Time Delay
O ₂ Sensor Warmup Time	10 min
O ₂ Proportional Band	500.0
O ₂ Integral Time	10.0 min
System Delay Time	10 sec

O₂ TRIM PI CONTROLLER

The O₂ Trim PI controller uses the configured O₂ Proportional Band and O₂ Integral Time settings to apply an offset to the configured Trim Channel to achieve the Target O₂ specified in the O₂ table. It is meant to be a slow acting controller to maintain appliance stability.

SYSTEM DELAY TIME

The system delay time specifies the sample time of the PI Controller and does not begin until after (1) the system has reached the Process Control State, and (2) sensor warmup has been satisfied.

OPERATING SEQUENCE

The following section outlines the controller states applicable to FARC applications as well as the proof of position and proof of airflow requirements for each. Refer to the [PF3100 Product Manual](#) for detailed state information including safety output behavior and transition requirements.

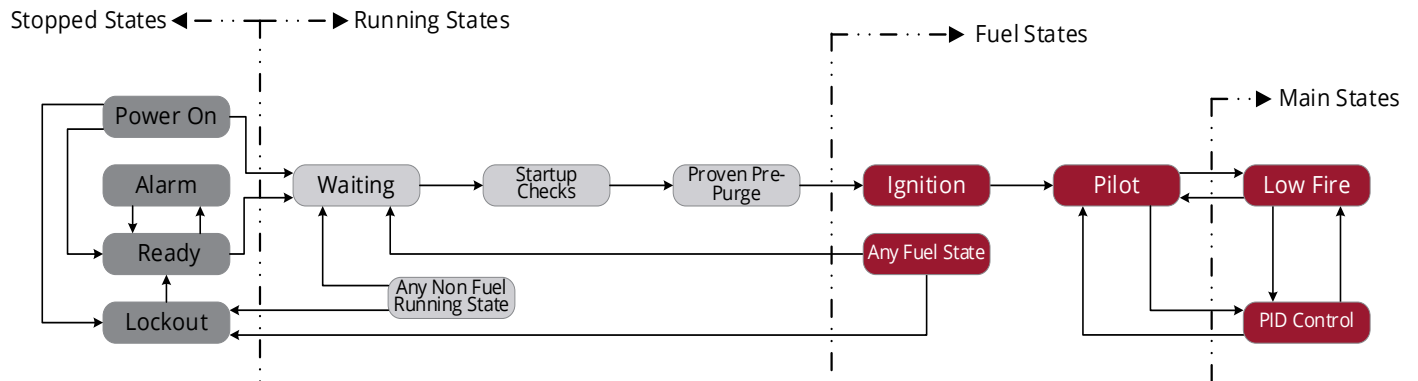

Controller State	FARC Channel	O ₂ Trim	Proof of Airflow
Power On	Off Position	Inactive	
Alarm	Off Position ¹	Inactive	N/A
Ready	Off Position ¹	Inactive	N/A
Lockout	Off Position ¹	Inactive	N/A
Waiting	Off Position ¹	Inactive	N/A
Startup Checks	Off Position	Inactive	must not be satisfied
Proven Pre Purge – Request Purge Position	Purge Position ²	Inactive	must be satisfied
Proven Pre Purge – Prove Airflow	Purge Position ³	Inactive	must be satisfied
Proven Pre Purge – Pre- Purge	Purge Position ³	Inactive	must be satisfied
Proven Pre Purge – Request Pilot Position	Pilot Position ²	Inactive	must be satisfied
Ignition	Pilot Position ³	Inactive	must be satisfied
Pilot	Pilot Position ³	Inactive	must be satisfied
Pilot – Request Light Off Position	Light Off Position per FARC Table ²	Inactive	must be satisfied
Low Fire	Light Off Position per FARC Table ³	Inactive	must be satisfied
PID Control	FARC Table position per effective firing rate or configured Manual Firing Rate	Active ⁴	must be satisfied

¹ If Purging, channel output matches configured Purge Position or last position in accordance with Post Purge Mode setting.

² System proceeds to Lockout if position is not satisfied within 90 seconds.

³ System proceeds to Lockout if position is not maintained for the duration of the state.

⁴ Following O₂ sensor warmup.

POSITION MONITORING

Channel position feedback inputs are continuously compared against their expected positions while the system is running. The system proceeds to Lockout if an actual position is outside the configured Position Error tolerance setting with respect to its expected position for the duration of the configured Position Error Timeout setting.

CROSS LIMITING

Cross limiting is applied to all channels to ensure that the current channel positions always adhere to the FARC Table. If the channel positions cannot be achieved at the system firing rate column of the FARC Table, the outputs are modulated in accordance with the Position Error and the Cross Limit Error setting to achieve the correct channel positions as configured in another column of the FARC Table – the column corresponds to the effective firing rate of the system. The system proceeds to Lockout if a fuel-air mixture consistent with the FARC Table cannot be maintained within the configured Position Error and Cross Limit Error tolerance settings.

SYSTEM FIRING RATE VS. EFFECTIVE FIRING RATE

The system firing rate is the current firing rate of the system and represents the column of the FARC Table to which all channel outputs are driven under ideal conditions. The system automatically adjusts channel outputs (through cross limiting) to maintain acceptable fuel-air mixtures in the event of stuck, inaccurate or slow-moving positioners that cause fuel rich conditions. The effective firing rate represents the FARC Table column corresponding to the feedback input reading of the channel causing the fuel-rich condition.

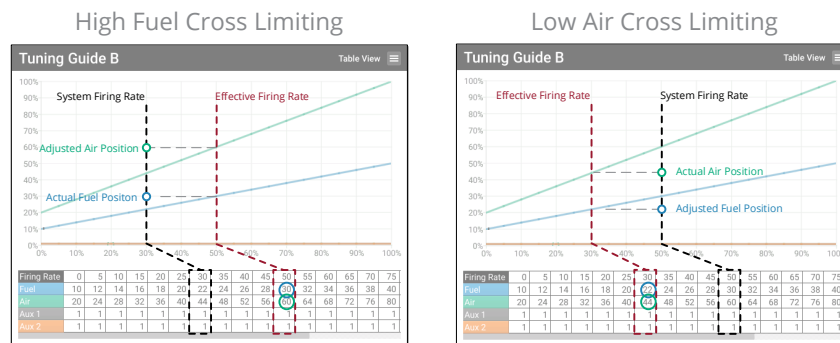

FLAT LINE TOLERANCE

The Flat Line Tolerance setting is meant to compensate for positioner inaccuracies that could cause chattering across flat sections of a FARC curve. The setting specifies the area above and below a flat section of a FARC channel curve within which the effective firing rate is ignored and outputs are held based on the system firing rate. Cross limiting is applied only when a channel feedback signal is outside its Flat Line Tolerance. The flat line tolerance applies to the entire operating range of the appliance - all three fuel positions indicated in the image below fall within the Flat Line Tolerance and result in the air position being held in accordance with the system firing rate rather than being cross limited in accordance with the effective firing rate.

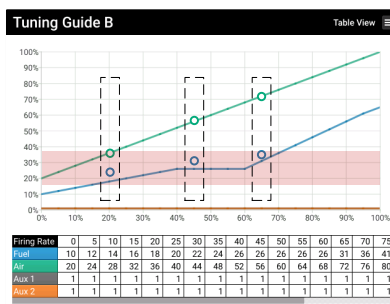

CROSS LIMITING EXAMPLES

EXAMPLE 1A - INACCURATE OR STUCK FUEL ACTUATOR:

The system is running at a firing rate of 20% and sourcing an 18% fuel position, but the fuel feedback input is reading 22%. The Flat Line Tolerance setting is indicated by the red box in each image below.

Fuel feedback position within Flat Line Tolerance

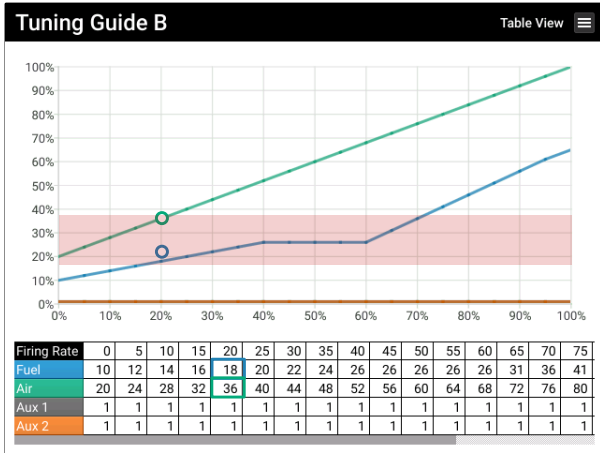

The controller attempts to drive the fuel channel to its FARC table position and holds the air channel output in accordance with the FARC table at the current firing rate.

Fuel feedback position outside Flat Line Tolerance

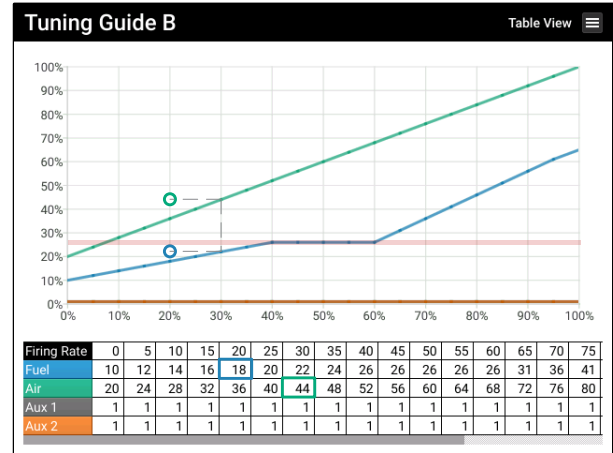

The controller attempts to drive the fuel channel to its FARC table position and automatically increases the air channel output from 36% to 44% to compensate for the higher-than-expected fuel position to maintain a safe fuel-air mixture.

EXAMPLE 1B - INACCURATE OR STUCK FUEL ACTUATOR:

The system is running at a firing rate of 55% and sourcing a 26% fuel position, but the fuel feedback input is reading 31%. The Flat Line Tolerance setting is indicated by the red box in each image below.

Fuel feedback position within Flat Line Tolerance

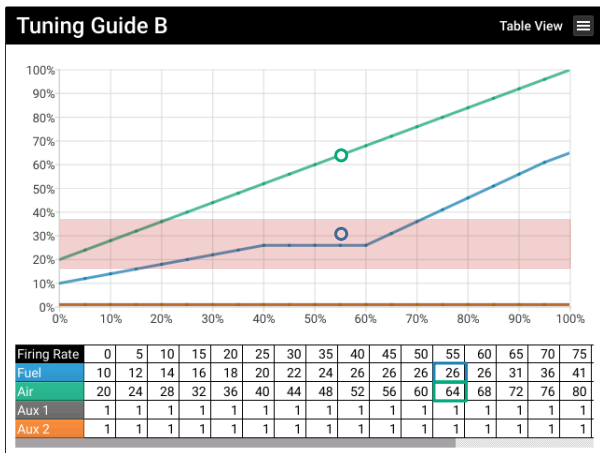

The controller attempts to drive the fuel channel to its FARC table position and holds the air channel output in accordance with the FARC table at the current firing rate.

Fuel feedback position outside Flat Line Tolerance

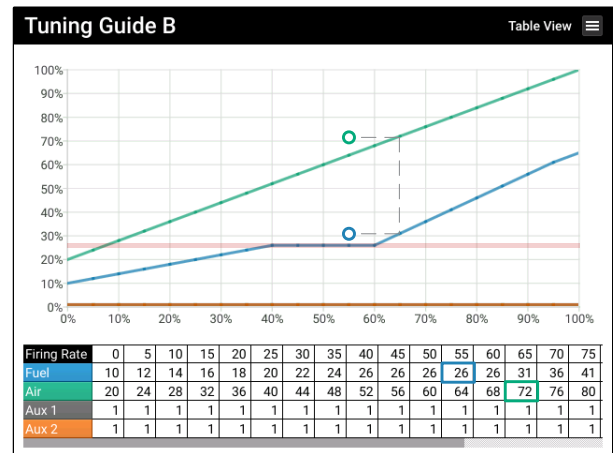

The controller attempts to drive the fuel channel to its FARC table position and automatically increases the air channel output from 64% to 72% to compensate for the higher-than-expected fuel position to maintain a safe fuel-air mixture.

EXAMPLE 2 - INACCURATE OR STUCK AIR ACTUATOR:

The system is running at a firing rate of 75% and sourcing an 80% air position, but the air feedback input is stuck at 76%. The Flat Line Tolerance setting is indicated by the red box in each image below.

Air feedback position within Flat Line Tolerance

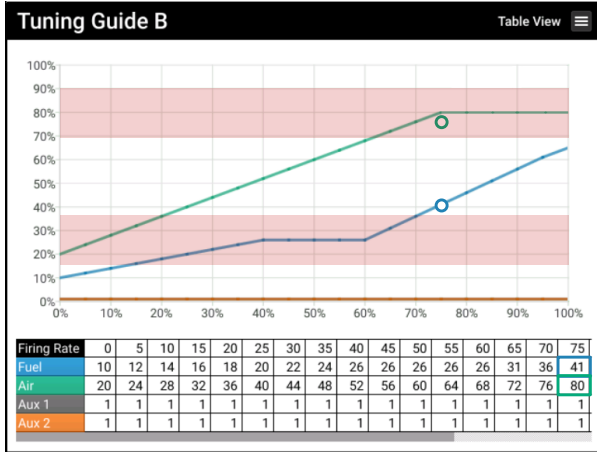

The controller attempts to drive the air channel to its FARC table position and holds the fuel channel output in accordance with the FARC table at the current firing rate.

Air feedback position outside Flat Line Tolerance

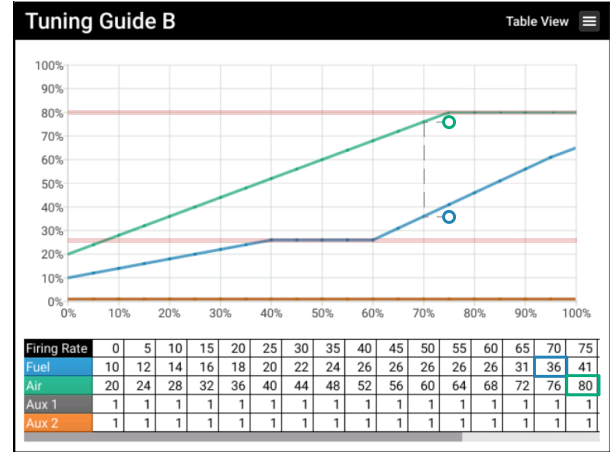

The controller attempts to drive the air channel to its FARC table position and automatically decreases the fuel channel output from 41% to 36% to compensate for the lower-than-expected air position to maintain a safe fuel-air mixture.

EXAMPLE 3 – CROSS LIMITING WITH A NEGATIVELY SLOPED FARC CHANNEL:

The system is running at 20% firing rate and sourcing an output of 80% to the Aux 2 channel, but the Aux 2 feedback input is stuck as indicated below.

Aux 2 configured as a lagging channel and stuck at 70%

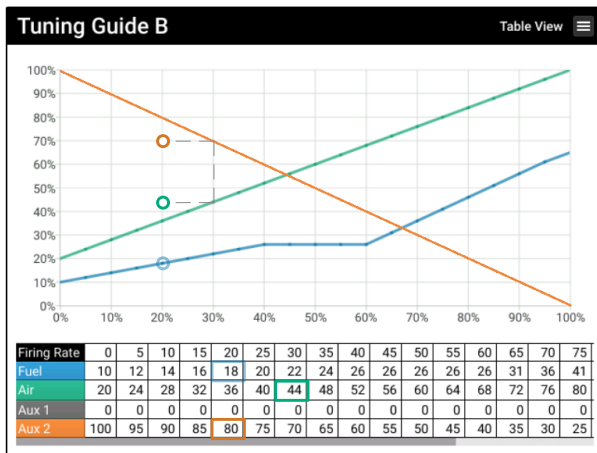

The system attempts to drive the Aux 2 output to its FARC table position and automatically increases the air channel output from 36% to 44% to compensate for the lower-than-expected Aux 2 channel position. The fuel channel output is not affected by lagging Aux channels.

Aux 2 configured as a leading channel and stuck at 90%

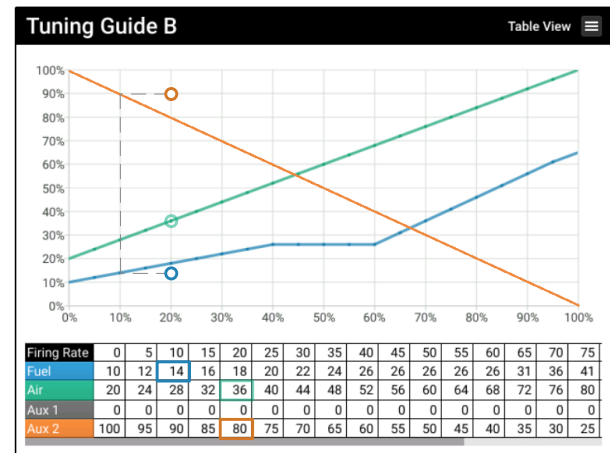

The system attempts to drive the Aux 2 output to its FARC table position and automatically decreases the fuel channel output from 18% to 14% to compensate for the higher-than-expected Aux 2 channel position. The air channel output is not affected by leading Aux channels.

6 COMMISSIONING

Prior to configuring FARC settings ensure the BMS system has been configured per design documentation and manufacturer specifications. This may include configuring temperatures, pilot modules, valves, instrumentation, etc. This section covers the configuration procedures for FARC functionality only - refer to the [PF3100 Product Manual](#) for commissioning instructions and descriptions of configuration options.

The FARC Configuration Wizard and all FARC settings are protected by the level 3 FARC password and should only be modified by qualified personnel. Please contact Profire for the password to modify these settings.

There are multiple methods that can be used to configure a FARC system. The method outlined in the steps below is designed to maximize control over the operating range of the appliance - the FARC Table 0% firing rate column is mapped to the minimum firing rate of the appliance and the 100% column is mapped to the maximum firing rate of the appliance ensuring that all 21 points on the table can be used to maintain stability.

FARC CONFIGURATION PROCEDURE

CREATE AND ASSIGN FARC INPUTS AND OUTPUTS

1. Skip this step if the appliance proof of airflow device is not wired to the BMS controller card (i.e., the proof of airflow device is wired to an I/O Expansion card). Otherwise configure the BMS Aux In input as a Proof of Airflow input (BMS Settings > Inputs > Aux In Contact > Aux In Contact Mode = Proof of Airflow).

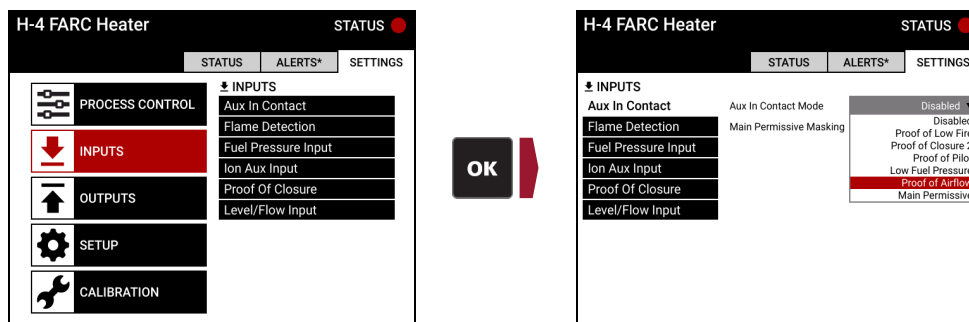

2. Open the I/O Wizard and advance to the Add Inputs Tab.
3. Create and name the following inputs:
 - Proof of Airflow input (if not using BMS Aux In above)
 - o Input Type: Custom
 - o Signal Type: Digital or 4-20mA per device type
 - o Input Mode: Proof of Airflow
 - o Name: Per equipment tag
 - o Units: As desired
 - o Low/High Setpoint and Deadband: Per design documentation.
 - FARC Fuel Position input
 - FARC Air Position input
 - FARC Aux 1 Position input (if required)
 - FARC Aux 2 Position input (if required)
 - FARC Aux 3 Position input (if required)
 - O2 Sensor (if required)

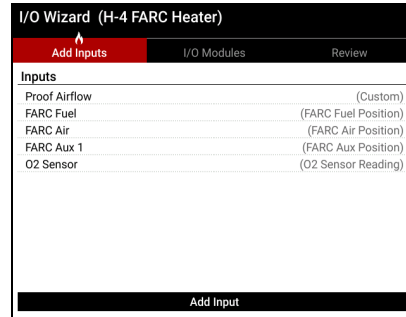
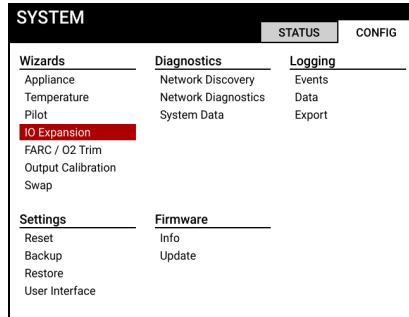

4. Advance to the I/O Modules Tab.
5. Assign each created input to the physical card input to which it is wired in the field (e.g., If the fuel position feedback input is wired to I/O Expansion card 1, Input 1 (terminals 8 & 9), select Input 1 from I/O Expansion card 1 and choose "FARC Fuel" from the assignment dialog).
6. Assign the Air channel output to the appropriate I/O Expansion card 4-20 Output slot in accordance with actual field wiring.
7. Repeat previous step for each auxiliary FARC channel as required (note: the fuel channel output is automatically assigned and must be wired to the BMS card Aux Out output - it cannot be assigned to an I/O Expansion output slot).
8. Advance to the Review Tab.
9. Ensure there are no errors then accept changes and exit the wizard.

CONFIGURE GENERAL FARC SETTINGS

10. Open the FARC/O2 Trim Wizard and advance to the General Tab.
11. Configure the settings as follows:
 - Set FARC Enable setting to Enabled.
 - Set 4-20 Aux Out Mode and Low Fire Mode per design documentation.
 - Set the Minimum Firing Rate setting to 0%.
 - Set the Light off Firing Rate setting to 5%.
 - Set the Flat Line Tolerance, Cross Limit Error, Position Error and Position Error Timeout settings in accordance with design documentation, heater manufacturer specifications and local safety codes.
 - Specify Names for Curve A and Curve B (e.g., Summer and Winter, Low Demand and High Demand, etc.)
 - Set Selected Curve setting as desired to specify the active curve.

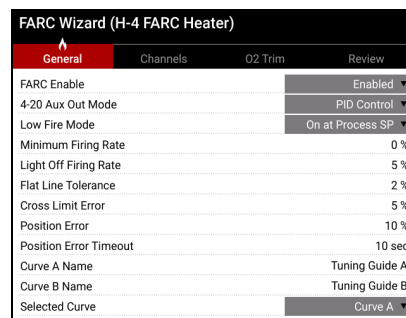
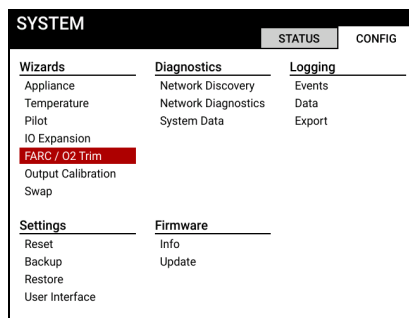

12. Advance to the Channels Tab.

13. Select the fuel channel to access its channel configuration dialog and configure as follows:
 - Set Name setting as desired.
 - Set Direction setting in accordance with actuator manufacturer specifications (i.e., positioner action).
 - Set Post Purge Mode and Purge Position settings in accordance with design documentation, heater manufacturer specifications and local safety codes.
 - Set Pilot Position to expected pilot position (to be adjusted during tuning).
 - Set Off Position as desired in accordance with design documentation, heater manufacturer specifications and local safety codes.

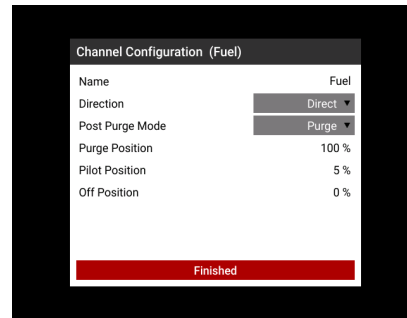
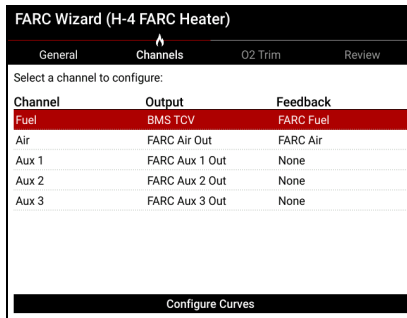

14. Repeat the previous step for the air channel.

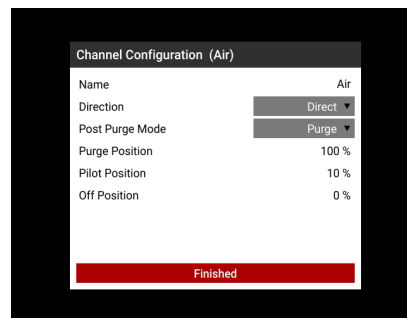
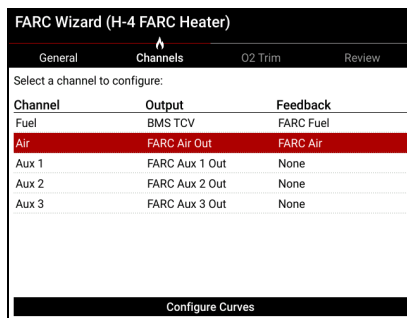

15. Repeat the previous step for each configured auxiliary channel (if required) with the following additional configuration items:
 - Set Position Feedback input and Cross Limiting settings as desired in accordance with design documentation, heater manufacturer specifications and local safety codes.

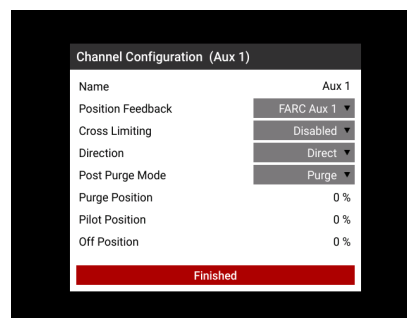
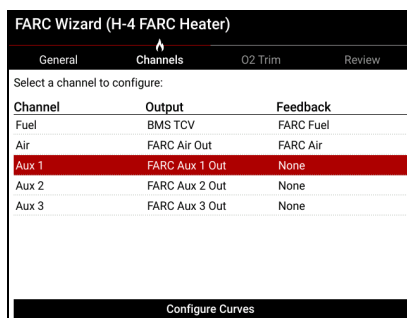

16. Select "Configure Curves" and configure the 5% firing rate column with the configured Pilot Position for each channel from the above steps.

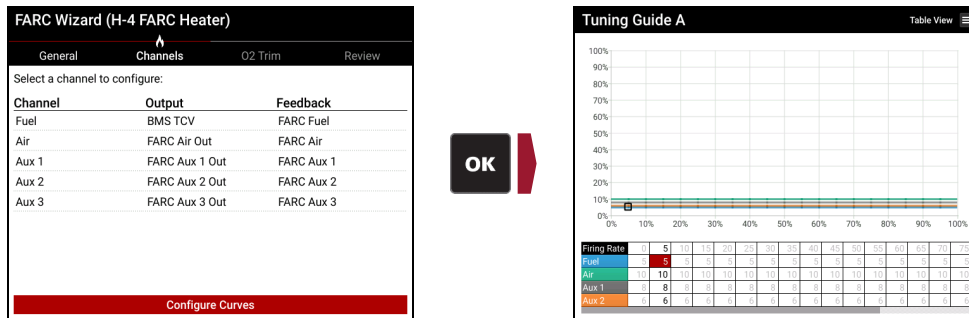

17. Advance to the O2 Trim Tab and leave O2 Trim disabled for now.

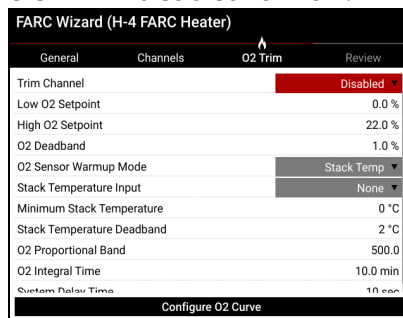

18. Advance to the Review Tab.
19. Ensure there are no errors then accept changes and exit the wizard.

CALIBRATE OUTPUTS

20. Open the Output Calibration Wizard.
21. Disconnect a FARC channel actuator from the PF3100 and connect a process calibrator/DMM configured to measure current in its place.

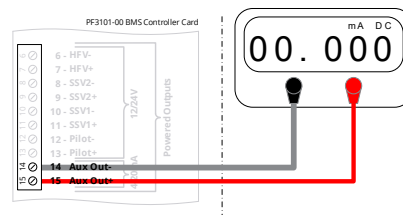

22. Follow on screen instructions to calibrate the output.
23. Disconnect the process calibrator/DMM and reconnect the output actuator.
24. Repeat above steps for all configured FARC channels.

TUNE SYSTEM FOR STABLE PILOT LIGHT OFF

25. Start the system. Ensure that the system does not transition into a main state during the following steps (the system will remain in the Pilot state for the duration of the Pilot to Main Delay setting in BMS Settings > Process Control > Timing. Ensure that any changes to this setting are reverted after Pilot tuning is complete).

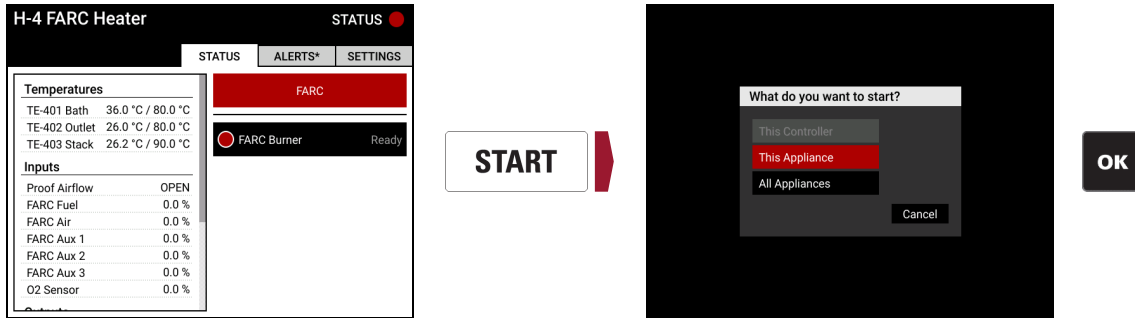

- 26. Observe pilot light off and pilot flame stability.
- 27. Open the FARC Status Screen.
- 28. Adjust Pilot Position for each channel until a stable pilot flame is established.



29. Stop the system before the transition into a main state.

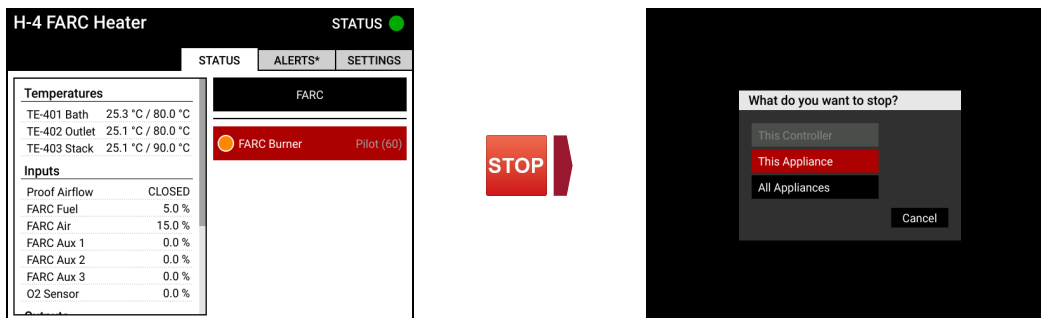

30. Restart the system and repeat above steps as necessary to ensure that the pilot flame ignites correctly and maintains stability.
31. Update the 5% Firing Rate column of the FARC Table to reflect the Pilot Positions for each channel.

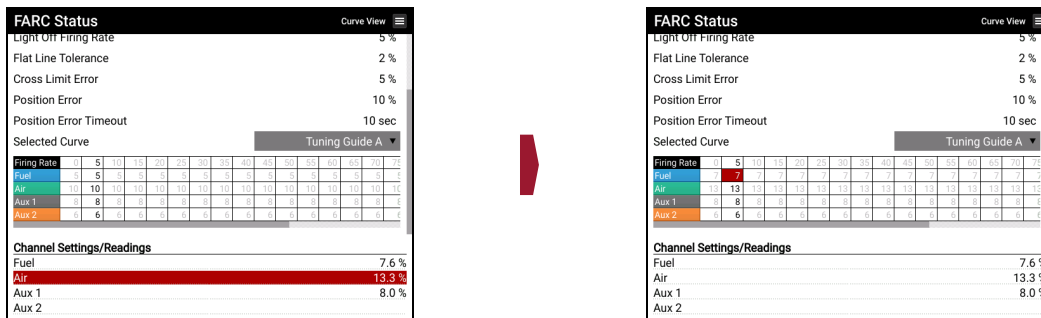

32. Ensure that any changes made to the Pilot to Main Delay setting in Step 25 are reverted back to their initial design values.

CONFIGURE FARC TABLE AT THE LIGHT OFF FIRING RATE

33. Set Manual Firing Rate to 5%.
34. Start the system and monitor the Pilot to Main light off transition and stack O₂ and CO readings.
35. Stop the system, adjust all the channel values in the FARC Table 5% Firing Rate column, then repeat the step above until correct Main Light off and appropriate stack readings are achieved.

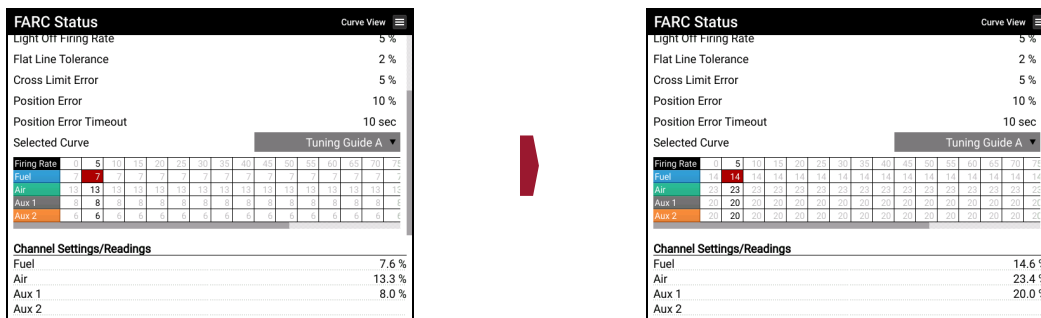

CONFIGURE FARC TABLE AT THE MINIMUM FIRING RATE

36. Set the Manual Firing Rate to 0%.
37. Start the system and allow it to proceed to the Manual Control state. Monitor the main flame and stack O₂ and CO readings.
38. Decrease 0% Firing Rate column fuel and air to the lowest possible values while maintaining flame/burner stability and appropriate stack readings.

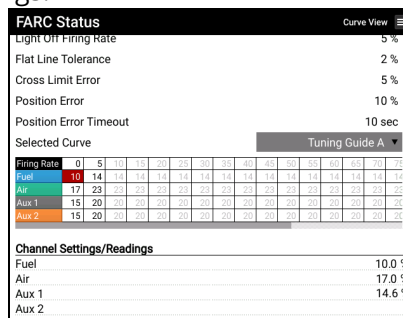

CONFIGURE FARC TABLE AT THE MAXIMUM FIRING RATE

- 39. Set the air channel to 100% in the 100% Firing Rate column of the FARC Table.
- 40. For multichannel FARC only: Set any configured leading auxiliary channels to 100% in the 100% Firing Rate column of the FARC Table

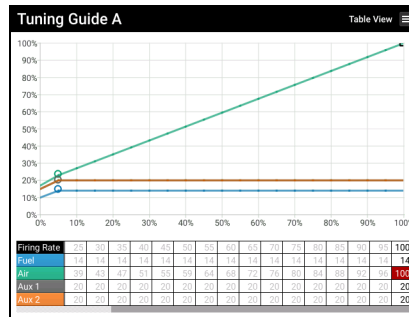

- 41. Keep the fuel channel flat between 5% and 100% (i.e., The 5% Firing Rate column and the 100% Firing Rate column must have the same value configured for the fuel channel).
- 42. For multichannel FARC only: Keep any configured lagging auxiliary channels flat between 5% and 100%.
- 43. Slowly increase the Manual Firing Rate to 100%.

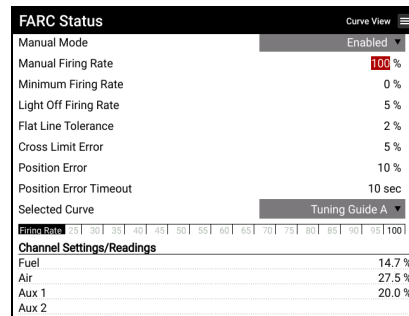

- 44. Increase the FARC Table 100% Firing Rate column fuel value until the appliance reaches its maximum BTU rating (ensure that fuel regulators are set correctly to ensure the ratings of the appliance are not exceeded)

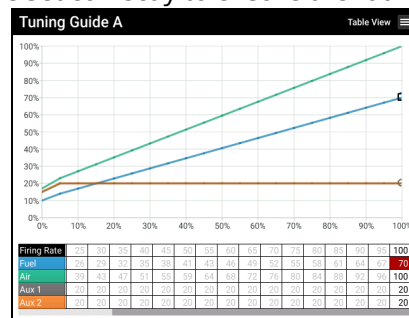

- 45. For multichannel FARC only: Increase the FARC Table 100% value for any configured lagging auxiliary channels until it is at its maximum.

- Adjust the FARC Table 100% Firing Rate column air value until stack readings indicate fuel-air mixture is correct per appliance manufacturer specifications.

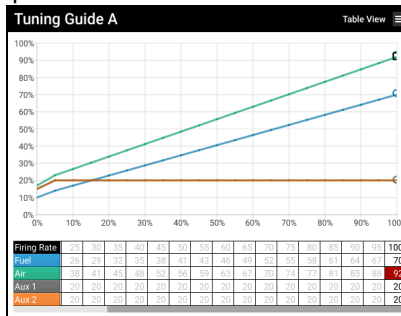

- For multichannel FARC only: Adjust the FARC Table 100% Firing Rate column for any configured auxiliary channel outputs per manufacturer specifications.
- Adjust the FARC Table 95% Firing Rate column air value to match its 100% column value.

CONFIGURE FUEL CHANNEL ACROSS ENTIRE TABLE

- Configure FARC Table 10% to 95% column fuel values with expected values based on appliance BTU (i.e., the configured fuel values do not necessarily have to increase linearly, but the corresponding expected BTU at each fuel value should be linear – expected BTU is indicated by the dashed line in the image below).

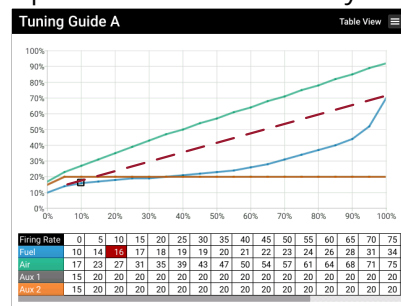

- For multichannel FARC only: Configure FARC Table 10% to 95% columns for any configured lagging auxiliary channels as applicable.

TUNE THE FARC TABLE BETWEEN 5% AND 95%

- For multichannel FARC only: Adjust the FARC Table 95% Firing Rate column for any configured leading auxiliary channels to match its 100% value.
- Change the Manual Firing rate to 95%.

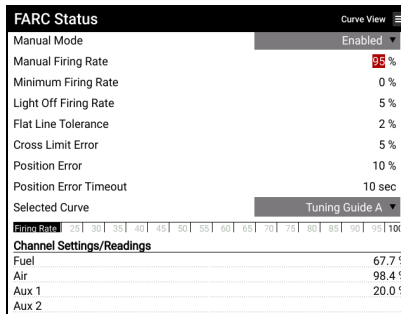

53. Adjust the air value in the FARC Table column corresponding to the Manual Firing Rate until stack readings are consistent with manufacturer specifications.

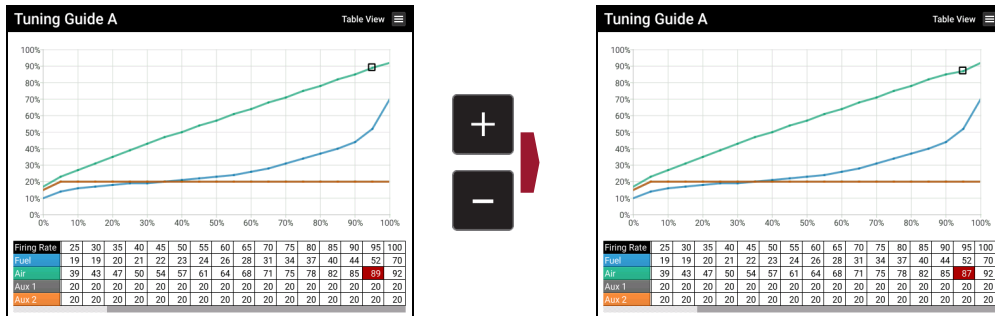

54. For multichannel FARC only: Adjust the values of the FARC Table column corresponding to the Manual Firing Rate for any configured auxiliary channels per manufacturer specifications.

55. Copy air value from the current column into the next lowest firing rate column. Do not overwrite previously configured columns (i.e., Light Off Firing Rate column).

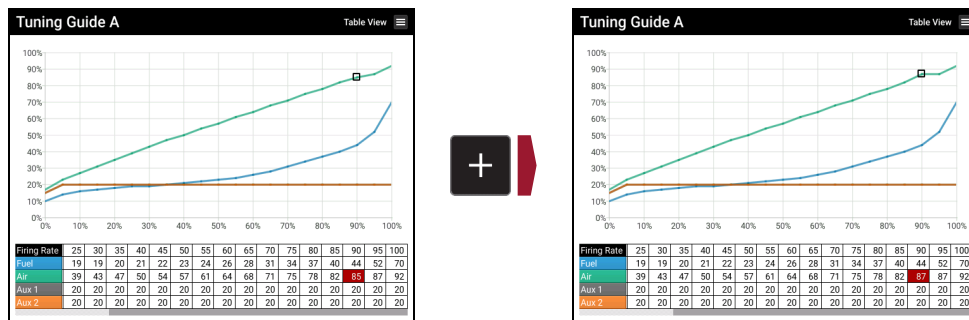

56. For multichannel FARC only: Copy any leading aux channel as with the air channel in the previous step

57. Decrease Manual Firing rate by 5% and repeat above steps. Repeat until the entire table is configured between 10% and 100% Firing Rate for all channels.

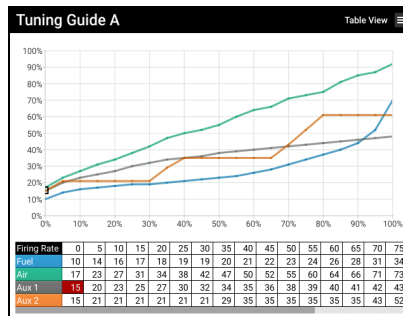

VALIDATE FARC TABLE

- 58. Set the Manual Firing Rate setting to match the Light Off firing rate.
- 59. Monitor flame stability and stack O₂ and CO readings while carefully increasing the Manual Firing Rate in ~20% increments up to 100% and then back down in ~20% increments. Adjust FARC Table values throughout to achieve smooth and safe transitions in both directions.
- 60. Repeat above validation steps with ~30% increments.
- 61. Repeat above validation steps with a single increase to 100% and a single decrease back to the Light Off firing rate.
- 62. Make any adjustments to the FARC Table as necessary.
- 63. Repeat all above validation steps until safe and smooth transitions have been achieved for all increments in both directions.

O₂ TRIM CONFIGURATION PROCEDURE

O₂ Trim must only be applied to a fully commissioned and tuned FARC system. Ensure that all previous steps are complete before proceeding with O₂ Trim configuration.

SET O₂ TRIM PARAMETERS

64. Stop the system
65. Open the FARC/O₂ Trim Wizard and advance to the O₂ Trim tab.
66. Enable O₂ Trim.
67. Set the Trim Channel setting as desired to specify whether the air or fuel channel is to be trimmed.
68. Set the Low and High O₂ Setpoints per design documentation and appliance manufacturer specifications.
69. Specify O₂ sensor warmup details per design documentation and sensor manufacturer specifications.
70. Configure Target O₂, Max Trim and Min Trim per appliance manufacturer specifications.
 - Target O₂: Desired stack O₂ reading in % for each firing rate
 - Max Trim: Maximum amount that the trimmed channel can be increased above its configured FARC Table value for a given firing rate.
 - Min Trim: Maximum amount that the trimmed channel can be decreased below its configured FARC Table value for a given firing rate.

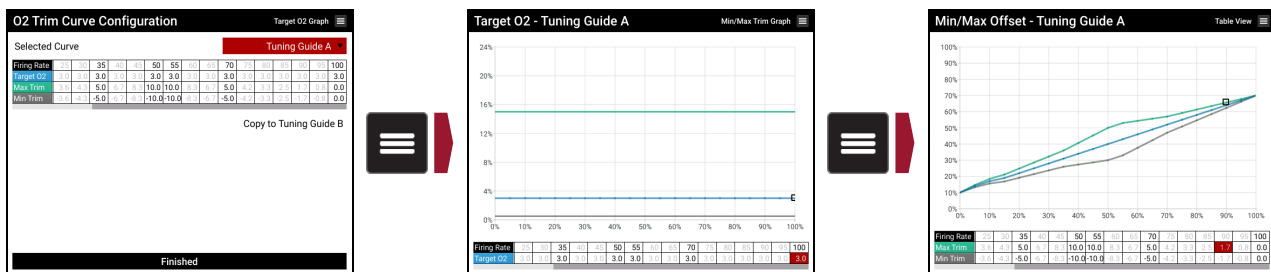

71. Start the system with the default O₂ Proportional Band and O₂ Integral Time settings and tune the PI loop as required to achieve stability while the system is actively trimming. The PF3100 Data Logging tool can be used as a tuning aid – refer to [PF3100 Product Manual](#) for details.

7 TROUBLESHOOTING

Issue	Corrective Action
Cross Limiting on Invalid Curve Alarm	Remove inflection points from all cross limited channel curves.
No Position Feedback on Cross Limited Channel Alarm	Ensure every cross limited channel has a feedback input assigned in the FARC/O ₂ Trim Wizard.
FARC Requires Proof of Airflow Alarm	Ensure that a Proof of Airflow input is configured on either the BMS card or an I/O Expansion card.
FARC Requires Forced Draft Fan Alarm	Ensure HFV Output Mode settings is set to Forced Draft Fan.
FARC Requires Low Fire Alarm	Ensure that Low Fire Mode setting is Enabled.
FARC Requires Aux Out Mode Alarm	Ensure Aux Out Mode setting is set to PID Control or Appliance Firing Rate
FARC Tables Require Commissioning Alarm	Ensure that the currently selected FARC Table has been configured.
FARC Fuel and Air Channels not Assigned Alarm	Ensure that fuel and air channels are configured correctly. Re-run the FARC/O ₂ Trim Wizard.
FARC Air Control Output Configuration Error Alarm	Ensure that the Air channel output is correctly assigned in the I/O Expansion Wizard
FARC Light Off Firing Rate Configuration Error Alarm	Ensure that the configured Light Off Firing Rate setting is greater than or equal to the configured Minimum Firing rate setting.
FARC Settings Out of Range Alarm	Ensure all channel outputs are calibrated and positioners are functioning properly. Re-run the Calibration Wizard.
Failed to Prove Purge Position Alarm	
Failed to Prove Pilot Position Alarm	
Failed to Prove Light Off Position Alarm	
Failed to Prove Airflow While Running Alarm	Ensure positioners operate smoothly and respond accurately to channel output signals.
Failed to Prove Airflow While Purging Alarm	
Cross Limit Error Alarm	
FARC Channel X Position Error Alarm	
FARC Feedback Missing Alarm	Ensure every cross limited channel has a feedback input assigned in the FARC/O ₂ Trim Wizard.

Issue	Corrective Action
FARC Redundant Inputs Alarm	Ensure all devices are wired and assigned to single card inputs only.
FARC Output Config Error Alarm	Ensure that each channel output is assigned to a single I/O Expansion output only.
Proof of Airflow Config Error Alarm	Ensure that only one proof of airflow input is configured.
Low %O ₂ Alarm	Ensure that oxygen sensor is functioning properly and warmup settings are appropriate for the sensor type.
O ₂ Trim Enabled Without Stack Temp Input Alarm	Ensure that a stack temperature is assigned when Warmup Mode is set to Stack Temp.
O ₂ Sensor Configuration Error Alarm	Ensure that an O ₂ sensor is not configured if FARC is disabled.
O ₂ Trim Requires Correctly Commissioned Curves Alarm	Ensure that O ₂ Trim curves have at least 2 configured columns.
Airflow Input Stuck Alarm	Ensure that proof of airflow device is unsatisfied during Startup Checks state.
FARC Enabled on Multi-Controller System Alarm	Ensure that FARC system is configured on an appliance with a single BMS controller card only.
FARC Feedback Configuration Error Alarm	Ensure every cross limited channel has a feedback input assigned in the FARC/O ₂ Trim Wizard.
O ₂ Trim Requires an O ₂ Sensor Alarm	Ensure that an O ₂ Sensor is configured in the I/O Expansion Wizard
O ₂ Trim At Limit Warning	No action required – For information. Consider re-tuning
High Measured %O ₂ Warning	No action required – For information. Consider re-tuning
Manual O ₂ Trim Warning	Ensure system is not in Manual Mode unless the system is being commissioned.
FARC Manual Mode Warning	
FARC Switch to Curve A Main Permissive	System does not switch curves while in a main fuel state.
FARC Switch to Curve B Main Permissive	

8 CANADIAN FIELD APPROVAL REQUIREMENTS

FARC systems in Canada must comply with the requirements found in CSA B149.3-20 Annex D. Canadian regulations generally require gas fired equipment to be field approved by an inspector prior to commissioning. The following table provides a summary of the Annex D requirements which Canadian inspectors will refer to and a corresponding explanation of how the PF3100 system meets each of those requirements. Note that some requirements are addressed inherently by the PF3100, others must be addressed through the engineering design of the overall system, and yet others must be addressed at the time of commissioning of the equipment. These requirements are labelled in the table below as being addressed by "PF3100", "System Design", and "Commissioning" respectively.

The standards requirements have been summarized, please refer to the applicable document for interpretation.

Summarized Requirement		Implementation	Addressed by:
D.2	Option to certify to ISO 23552-1.	The PF3100 is not currently certified to this standard.	
	Option to use a microprocessor-based system compliant with clause 12.7.	The PF3100 does comply with this requirement.	PF3100
	Option to integrate FARC with the BMS.	The PF3100 does integrate these features. The PF3101-00 BMS Controller card runs the FARC control algorithm and may be configured to use IO on additional PF3100 family cards.	PF3100
	Option to use a non-certified system compliant with the following additional requirements.	The PF3100 FARC feature set is not certified (as per ISO 23552-1) and does comply with the following requirements.	PF3100
D.2 a	The FARC system shall be evaluated as a closed loop system.	Control of the FARC system is based on positioning according to the fuel air ratio table and the appliance firing rate and relies on a closed loop feedback to verify correct operation.	PF3100, System Design
D.2.b.i	Continuous feedback of actuator/fan positions to ensure requested position has been achieved.	Feedback is provided via 4-20 analog input signals. If the position feedback is lost or the signal goes out of the 4 - 20mA range the system will alarm. If the end device has a fault available as a digital output, it can be connected as a system alarm.	PF3100, System Design
D.2.b.ii	The inability of any actuator/fan to achieve the requested position shall be detected and the corresponding actuator/fan shall be prevented from traveling past the corresponding position.	The requested position is compared to the feedback position. If this difference is larger than the position error setting for a duration greater than the Position Error Timeout setting the system will alarm. The corresponding actuator cannot travel past the corresponding position due to the cross limiting between the two positions.	PF3100, System Design
D.2.b.iii	The actuator/fan error tolerance shall be within the appliances safe operating range.	The error tolerance between the requested position and the feedback position can be adjusted to be within the safe operating range of the appliance. Positioning that is outside of the tolerance will cause a system alarm.	PF3100, System Design, Commissioning

Summarized Requirement		Implementation	Addressed by:
D.2.b.iv	Cross limiting shall be used to be ensure the error tolerance is not exceeded.	Cross limiting is used to enforce a safe fuel/air ratio. When the firing rate is increased the air position will increase first with the fuel position following behind it. On air position increase the air position will only be adjusted to a maximum of the position error limit before waiting for the fuel flow to increase. It will step up to the requested position while maintaining its limit within the position error. When the firing rate is decreased the fuel will decrease first with the air position following behind it. On fuel decrease the fuel flow will only be adjusted to a minimum of the position error limit before waiting for the air position to decrease. It will step down to the requested position while maintaining its limit within the position error. Auxiliary channels, if cross limiting is enabled, will act as the air does above if set to lead and will act as the fuel does above if set to lag.	PF3100
D.2.b.v	Upon detection of a position fault or any other unsafe condition the system shall revert to a risk adverse state or shutdown.	If a position fault is detected or any other unsafe condition the system will alarm and shutdown.	PF3100
D.2.b.vi	The valve or air position must be accurately measured. This may be done by using a shaft position sensor. Any linkages between the position sensor and the actual air actuator must be fully secured.	This requirement must be met via the installation method and equipment used.	System Design
D.2.b.vii	The actuator assembly must have indication of position.	This requirement must be met via the equipment used.	System Design
D.2.b.viii	Purge and light off position must be interlocked with the system.	The purge position is verified before beginning the purge state. The light off position is verified before lighting off the main burner. The position tolerance is continually monitored to be within the position error in all states. If the error is out of tolerance the system will not start due to an alarm or shutdown if already running.	PF3100
D.2.b.ix	If a variable speed fan is used, secondary feedback must be used from the fan including current, fan speed, or flow sensor.	Feedback is provided via the 4-20mA analog feedback input. The feedback must match the requested position within the position error.	PF3100, System Design
D.2.c	Meter type system	The PF3100 is a positioning type system, so this condition does not apply.	
D.2.d	A checker system may optionally provide redundant confirmation of valve/air/fan positions, airflow, pressures and temperatures.	No additional checker system is implemented. The FARC and BMS control are integrated into one solution. The BMS side of the system will verify the airflow (airflow switch), fuel pressure limits and temperature limits.	PF3100

Summarized Requirement		Implementation	Addressed by:
D.2.e	If O2 Trim is used its control range must be limited to +/- 10% of combustion airflow.	The control range is limited to +/- 10% of combustion airflow	PF3100
D.2.f	The FARC system must be interlocked with the BMS controller to ensure proper operation. The following must be proven before starting the system: All communication links, Confirmation of purge position, Low fire position, and fail-safe trip in the case the FARC system detects a fault.	The FARC system is fully interlocked with the BMS controller. The communication links are continually verified, if they are lost then the system will alarm and shut down. Purge position is verified before beginning the purge state. If an airflow transmitter is used, it is verified to indicate no airflow before starting the fan. If an airflow switch is used it is verified to be open before starting the fan. Proof of light off position is verified before lighting off the mains.	PF3100
D.2.g	The combustion control microprocessor may be independent from the BMS or incorporated into a PLC based burner management system.	The BMS and FARC control system is incorporated on the same platform and is SIL certified as a safety system according to IEC 61508.	PF3100
D.2.h	FARC tables and related settings are password protected.	All fuel air ratio table adjustments and FARC settings require a level 3 operator password to be adjusted.	PF3100
D.2.i	The system shall shutdown (or annunciate a warning depending on application) if a sensor or an actuator has a fault or if the FARC system has a fault.	The system will alarm and shutdown if a sensor such as a position sensor or an actuator has a fault. Additional device faults can be connected into the system as an alarm. All alarms are annunciated.	PF3100
D.2.j	The system must shutdown if readings exceed a safe limit as declared by the appliance manufacturer.	The safe limit of operation for the FARC system is defined by the position error and the cross-limit error. If the system exceeds these limits it will alarm and shutdown. This tolerance should be set by a qualified professional that is familiar with the appliance requirements.	PF3100, System Design, Commissioning
D.2.k	The system must be protected from RF interference.	The system meets noise immunity levels and has been tested against IEC 61000-4	PF3100
D.2.l	The system must be commissioned by a qualified technician along with regularly maintained.	This requirement must be met via the commissioning party. The requirement for regular maintenance and for the system to be commissioned by a qualified technician is stated in the user manual.	Commissioning

9 VERSION HISTORY

Document Version	Release date	Changes
v8.0	04MAY2022	Updated Cross Limiting examples
v7.0	31JAN2022	Updated for NA-43.0 firmware release: <ul style="list-style-type: none"> - Added multichannel support - Added O₂ Trim support - Added hardware and installation sections - Added commissioning procedure - Reformatted document
v6.0	12MAR2021	Updated for NA-42.0 firmware release: Added new "Airflow Control Type" setting. Updated to reflect changing of "Damper" references to "Air" for new VFD feature
v5.0	26NOV2020	Updated for NA-41.1 firmware release: Changed the cross limit maximum value from 5% to 15%
v4.0	11JUN2020	Updated for NA-41 firmware release: Changed references to fuel flow and air flow to fuel position and air position where related to the positioning of the actuators. Added additional details to explain cross limit and position errors. Added light off position. Added defaults and ranges for FARC settings. Position error default changed to 2%. Cross limit error default changed to 1%. Improved description of light off firing rate. Improved description of the effect the position error has on excess air during firing rate transitions. The cross limit error does not have any control over modulating excess air. Updated description of start/stop and wait sequences. Positioning timeouts and airflow timeouts have now been extended to 90 seconds. Startup purging section has an extended description of purge positioning requirements in this state. Pilot ignition section now refers to maintaining the pilot position throughout this state. Position error timeout minimum has been changed from 0 to 1 second. Fuel Air table firing rate description updated. Cross limiting description clarified regarding excess fuel shutdown. Updated settings table to show authentication level and if editable while running. Updated description of post purge not requiring position proving and the effect this has on purge time.