



PF2200 - DB

PRODUCT MANUAL

**Warning:**

All PF2200 installations must follow the installation, commissioning, operation, and maintenance procedures outlined in this manual. Failure to comply with the instructions and warnings in this manual may result in death, serious injury, electrocution, property damage, product damage, and/or government fines. All PF2200 installations must be performed in accordance with local electrical code(s) by a capable electrician, and must be field inspected by the Authority Having Jurisdiction to ensure compliance with local electrical and gas codes.

Explosion Hazard. Do not connect or disconnect when energized.

Do not service or open enclosure unless power has been switched off or the area is known to be non-hazardous.

Do not remove or replace fuse when system is powered. Replacement fuses must be ceramic and of correct rating (10A, 150V_{DC}, Slow Blow). Contact Profire for fuse replacements.

All safety functions must be end-to-end proven following commissioning of the system.

Substitution of components may impair suitability for Class I, Division 2.

**Avertissement:**

Toutes les installations PF2200 doivent être conformes aux procédures d'installation, de mise en service, d'utilisation et d'entretien décrites dans ce manuel. Le non-respect des instructions et des avertissements de ce manuel peut entraîner la mort, des blessures graves, l'électrocution, des dommages matériels, des dommages au produit et/ou des amendes gouvernementales. Toutes les installations PF2200 doivent être effectuées conformément au(x) code(s) électrique(s) local(aux) par un électricien compétent, et doivent être inspectées sur place par l'autorité compétente afin de garantir la conformité aux codes locaux de l'électricité et du gaz.

Risque d'explosion. Ne pas brancher ni débrancher sous tension.

Ne pas réparer ou ouvrir le boîtier si l'instrument est sous tension ou que la zone est reconnue pour être non-dangereuse.

Ne pas retirer ou remplacer le fusible lorsque le système est sous tension. Les fusibles de remplacement doivent être en céramique et de valeur nominale correcte (10A, 150VDC, slow blow). Contactez Profire pour le remplacement des fusibles.

Toutes les fonctions de sécurité doivent être éprouvées de bout en bout après la mise en service du système.

La substitution de composants peut rendre ce matériel inacceptable pour les emplacements de Classe I, Division 2.

CONTENTS

1 SCOPE.....	4	6 INSTALLATION.....	61
2 APPROVALS AND RATINGS	4	6.1 Mounting Considerations.....	61
2.1 Product Declarations	5	6.2 Connection Diagrams	62
2.2 Electrical And Mechanical Ratings	6	7 SYSTEM CONFIGURATION	68
3 USER INTERFACE CARD	9	7.1 Temperatures	68
3.1 Keypad	9	7.2 Inputs.....	71
3.2 Controller Interface	10	7.3 Process Control.....	76
3.3 Status LED.....	15	7.4 Outputs.....	78
3.4 Modbus Communication	15	7.5 Setup	80
3.5 USB Port.....	16	8 MAINTENANCE	82
4 BMS CARD	17	8.1 Transportation and Storage Conditions	82
4.1 Upstream Pressure Input	18	8.2 Repair and Replacement	82
4.2 Burner A Pressure Input.....	20	8.3 Decommissioning.....	82
4.3 Burner B Pressure Input.....	21	8.4 Useful Life.....	82
4.4 Burner A Proof of Closure Input	22	8.5 Manufacturer Notification.....	82
4.5 Burner A Temperature Control Valve Output	23	9 TROUBLESHOOTING	83
4.6 Burner A Pilot Valve Solenoid Output	25	10 ALERT CODES & RESPONSE TIMES	84
4.7 Burner B Pilot Valve Solenoid Output	26	10.1 Alarms.....	84
4.8 Burner A Main Valve Solenoid Output	27	10.2 Waits	89
4.9 Burner B Main Valve Solenoid Output	28	10.3 Warnings.....	90
4.10 Upstream Main Solenoid Valve Output	29	10.4 Main Permissives.....	92
4.11 Status Contact.....	30	11 GLOSSARY	93
4.12 Controller Power Input	31	12 ACRONYMS	94
4.13 Emergency Shutdown Input.....	32	13 DOCUMENT REVISION HISTORY	95
4.14 Remote Start Input	33		
4.15 Auxiliary Output.....	34		
4.16 Burner B Temperature Control Valve Output	35		
4.17 Level/Flow Input	36		
4.18 Auxiliary Temperature Input	37		
4.19 Auxiliary Inputs	39		
4.20 Burner B Proof of Closure Input.....	42		
4.21 Upstream Proof of Closure Input	43		
4.22 Pilot Ignition I/O	44		
4.23 External Ignition Switch Input	45		
4.24 Bath Temperature Input.....	46		
4.25 Outlet/Burner B Stack Temperature Input.....	47		
4.26 Shared Stack/Burner A Stack Temperature Input .	49		
5 OPERATING SEQUENCE	50		
5.1 Power On State	51		
5.2 Lockout State	52		
5.3 Alarm State.....	54		
5.4 Ready State.....	55		
5.5 Waiting State	56		
5.6 Ignition State	57		
5.7 Pilot State.....	58		
5.8 Main Light Off State.....	59		
5.9 Process Control States.....	60		

1 SCOPE

The PF2200-DB Burner Management System is an automated safety controller designed to monitor and control industrial heating processes that utilize dual burner natural draft appliances. It provides for safe burner ignition, ionization flame detection, temperature control and peripheral input device monitoring for two independent burners. The user interface provides real-time system status and state information as well as detailed alert annunciation, advanced diagnostics and data logging. The system has been optimized for power consumption to be utilized in a variety of applications and can be monitored remotely.

This document provides detailed descriptions of the PF2200-DB inputs, outputs and operating sequence as well as installation, maintenance and commissioning instructions. This document is applicable for the following hardware and firmware versions:

BMS Card Hardware Version	UI Card Hardware Version	PF2200-DB Firmware Version
v2.3.x	v3.2.x	DB 1.1.0

Contact Profire if you require a previous version of the PF2200-DB Product Manual.

The card hardware versions and current system firmware can be found on the Information screen (System > Firmware > Info) of the User Interface, where the BOM Version corresponds to the card hardware and Bundle Version corresponds to the system firmware. Additionally, the card hardware version is printed on the last line of the QR code label affixed to each card.

Note that the BMS firmware version and the UI firmware version must match in order for the system to operate correctly. Mismatched firmware is not supported.

2 APPROVALS AND RATINGS

The PF2200-DB is approved for use in a 1oo1 deployment configuration and is certified to the following standards:



SIL 2 Capable
IEC 61508: 2010 Parts 1-7



Electrical Burner Control System
UL 60730-2-5/ ANSI Z21.20-2014 • CSA C22.2 No. 60730-2-5
Class I Div 2 Group A, B, C & D, T4A (Class I, Zone 2, Group IIC – US Only)
UL 121201 • CSA-C22.2 No. 213



Type 4X
CSA C22.2 No. 94.1:15 • CSA C22.2 No. 94.2:15, Ed. 2
UL 50:15, Ed. 13 • UL 50E:15, Ed. 2
IP66
CSA-C22.2 No. 60529:16

2.1 PRODUCT DECLARATIONS

System Parameter	Value
Maximum Flame Detector Response Time	50ms
Minimum Flame Detector Self-Checking Rate	1Hz
Maximum Flame Failure Lock-Out Time	4s
Maximum Flame-Failure Reignition Time	1s
Maximum Ignition Time	11s
Maximum Pilot-Flame Establishing Period	10s
Maximum Post-Ignition Time	2.5s
Maximum Pre-Ignition Time	1s
Minimum Purge Time	10s
Minimum Recycle Time	10s ^{Note 1}
Maximum Start-up Lock-Out Time	10s ^{Note 2}
Maximum Number of Start-Up Retries	3
Minimum Waiting Time	5s
Pollution Degree	1 ^{Note 3}
Signal for Absence/Presence of Flame	-2.54V ^{Note 4}
High Voltage Spark Gap Range	2 – 8mm
Types of Action	Type 2: Electronic Disconnection, Non-volatile Lockout, Permanent Operation
Types of Burners	Full Rate Start and Low Rate Start
Type of Control	Incorporated Control
Types of Ignition	Interrupted
Types of Pilot	Continuous and Intermittent

¹ Automatic Recycle is only permitted upon loss of a proven flame when configured **Relight Attempts** settings is not set to **0**.

² Since recycling is allowed, this time is from fuel flow energizing on start-up to fuel flow de-energize due to no flame presence.

³ Pollution degree when installed in enclosure with a rating of IP54 or equivalent

⁴ Flame signal is the amount that the AC signal being applied to the flame rod is rectified (i.e. the DC offset to the AC waveform)

2.2 ELECTRICAL AND MECHANICAL RATINGS

2.2.1 PRODUCT RATINGS

Type	Rating
Temperature - Operating	-40°C to 55°C (-40°F to 131°F)
Temperature - Storage	-40°C to 55°C (-40°F to 131°F)
Voltage Range - 12V Mode	10.2 V _{DC} to 16.2 V _{DC}
Voltage Range - 24V Mode	20.4 V _{DC} to 32.4 V _{DC}
Power Consumption - 12V Mode	Running with USB installed: 1.1 W, No USB: 0.7 W
Power Consumption - 24V Mode	Running with USB installed: 1.3 W, No USB: 0.9 W
Humidity - Product	0% to 100% Condensing
Humidity - BMS and UI Card	0% to 90% Non-condensing
Vibration - Tested	3g swept from 10Hz to 150Hz, 10 consecutive sweeps, 3-axis
Enclosure	304 Stainless Steel, Type 4X, IP66
Enclosure Dimensions	335mm x 251mm x 145mm (13.2" x 9.9" x 5.7")
Enclosure Weight	7.26 kg / 16 lbs.

A #2 Phillips screwdriver is required to open and close the enclosure.

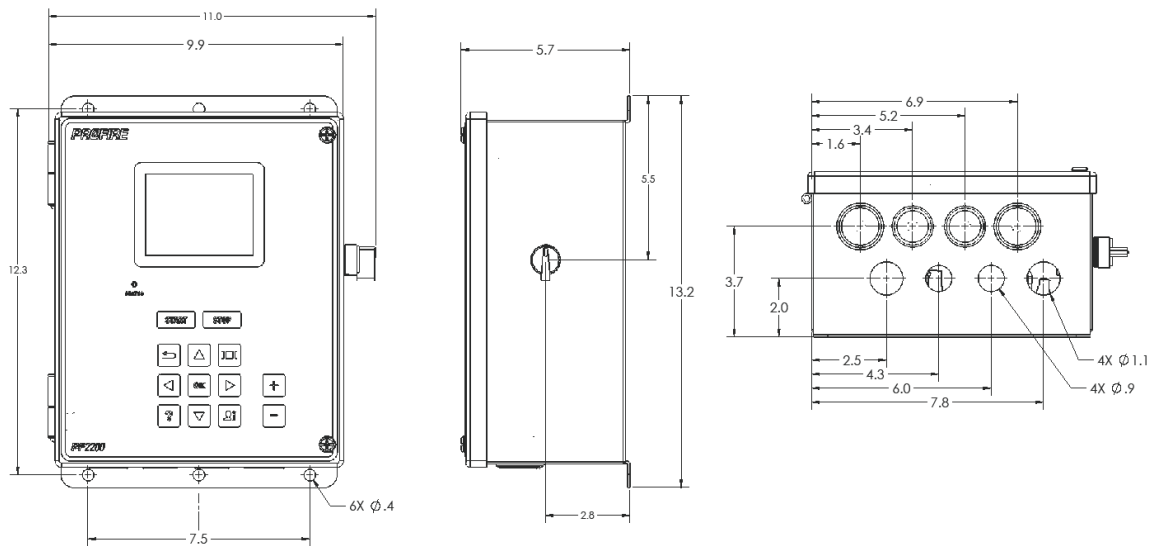

2.2.2 USER INTERFACE CARD ELECTRICAL RATINGS

Terminal	Input/ Output	Rating	AWG		Torque (Nm)		
			Min	Max	Min	Max	
MODBUS	1 A	RS-485, -7V – 7V Common Mode Range with reference to terminal 3 (-)	30	14	0.22	0.25	
	2 B						
	3 -						
PFN	1 +	O	30	14	0.22	0.25	
	2 PFN A	I/O					
	3 PFN B	I/O					
	4 -	O					
USB	- USB	I/O	5V _{DC} , 200mA max	-	-	-	-
KEYPAD	- KEYPAD	I	3V _{DC} , 4.75kΩ source impedance	-	-	-	-

2.2.3 BMS CARD ELECTRICAL RATINGS

Name	Safety Rated	Terminal	Input/ Output	Rating	AWG ⁴		Torque (Nm)	
					Min	Max	Min	Max
USER INTERFACE	NO	1 +	O					
		2 PFN A	I/O	Power Out: 7-35V _{DC} , 500mA Max	30	14	0.22	0.25
		3 PFN B	I/O	PFN: -7V – 7V Common Mode Range				
		4 -	O					
PRESS. UP	YES	5 PWR	O	12V Mode: 12V _{DC} , 24V Mode: 13.5V _{DC} , 30mA Max				
PRESS. A	YES	6 SIG IN	I	30V _{DC} Max ^{2,3}	30	12	0.5	0.6
		7 PWR	O	12V Mode: 12V _{DC} , 24V Mode: 13.5V _{DC} , 30mA Max				
PRESS. B	YES	8 SIG IN	I	30V _{DC} Max ^{2,3}	30	12	0.5	0.6
		9 PWR	O	12V Mode: 12V _{DC} , 24V Mode: 13.5V _{DC} , 30mA Max				
PoC A	YES	10 SIG IN	I	30V _{DC} Max ^{2,3}	30	12	0.5	0.6
		11 PWR	O	12V Mode: 12V _{DC} , 24V Mode: 13.5V _{DC} , 30mA Max				
TCV A	NO	12 SIG IN	I	30V _{DC} Max ²	30	12	0.5	0.6
		13 OUT	O	20mA Max Output, Expected Load: < 350Ω				
PILOT A	YES	14 GND		±0.1 mA Accuracy	30	12	0.5	0.6
		15 +	O					
PILOT B	YES	16 -	O		30	12	0.5	0.6
		17 +	O					
SSV A	YES	18 -	O	12V _{DC} /24V _{DC}	30	12	0.5	0.6
		19 +	O	5A Max				
SSV B	YES	20 -	O	Pulsed Output with configurable PWM	30	12	0.5	0.6
		21 +	O	Expected Load: Inductive/Resistive				
SSV UP	NO	22 -	O		30	12	0.5	0.6
		23 +	O					
RUN STATUS	NO	24 -	O		30	12	0.5	0.6
		25 A	-	120V, 170Vpk Max				
		26 NOT USED		1500V Max impulse				
EGND	NO	27 B	-	1A _{RMS} Max	30	12	0.5	0.6
		28 EGND		Earth ground terminal				
POWER IN	NO	29 -			30	12	0.5	0.6
		30 -	I	12V _{DC} /24V _{DC}				
		31 +	I	10A Max				
ESD	YES	32 +			30	12	0.5	0.6
		33 PWR	O	12V Mode: 12V _{DC} , 24V Mode: 13.5V _{DC} , 30mA Max				
START	YES	34 SIG IN	I	30V _{DC} Max ²	30	12	0.5	0.6
		35 PWR	O	12V Mode: 12V _{DC} , 24V Mode: 13.5V _{DC} , 30mA Max				
AUX OUT	NO	36 SIG IN	I	30V _{DC} Max ²	30	12	0.5	0.6
		37 OUT	O	20mA Max Output				
TCV B	NO	38 GND		Expected Load: < 350Ω	30	12	0.5	0.6
		39 OUT	O	±0.1 mA Accuracy				
LEVEL/ FLOW	YES	40 GND			30	12	0.5	0.6
		41 PWR	O	12V Mode: 12V _{DC} , 24V Mode: 13.5V _{DC} , 30mA Max				
		42 SIG IN	I	30V _{DC} Max ^{2,3}				

Name	Safety Rated	Terminal	Input/ Output	Rating	AWG ⁴		Torque (Nm)	
					Min	Max	Min	Max
AUX TEMP	YES	43 PWR	O	12V Mode: 12V _{DC} , 24V Mode: 13.5V _{DC} , 30mA Max	30	12	0.5	0.6
		44 SIG IN	I	30V _{DC} Max, ±0.5 mA Accuracy				
AUX IN 1	YES	45 PWR	O	12V Mode: 12V _{DC} , 24V Mode: 13.5V _{DC} , 30mA Max	30	12	0.5	0.6
		46 SIG IN	I	30V _{DC} Max ^{2 3}				
AUX IN 2	YES	47 PWR	O	12V Mode: 12V _{DC} , 24V Mode: 13.5V _{DC} , 30mA Max	30	12	0.5	0.6
		48 SIG IN	I	30V _{DC} Max ^{2 3}				
POC B	YES	49 PWR	O	12V Mode: 12V _{DC} , 24V Mode: 13.5V _{DC} , 30mA Max	30	12	0.5	0.6
		50 SIG IN	I	30V _{DC} Max ²				
POC UP	YES	51 SIG IN	I	30V _{DC} Max ²	30	12	0.5	0.6
		52 NOT USED						
PILOT A ION	YES	53 +	I/O	Intermittent 80-130 V _{RMS} Output	30	12	0.5	0.6
		54 -	I/O					
PILOT A COIL	YES	55 -	O	12V _{DC} /24V _{DC} Pulsed Output	30	12	0.5	0.6
		56 +	O	Expected Load: Inductive				
PILOT B ION	YES	57 +	I/O	Intermittent 80-130 V _{RMS} Output	30	12	0.5	0.6
		58 -	I/O					
PILOT B COIL	YES	59 -	O	12V _{DC} /24V _{DC} Pulsed Output	30	12	0.5	0.6
		60 +	O	Expected Load: Inductive				
BATH	YES ¹	61 +	I	Thermocouple Mode: Type K Grounded or Ungrounded -100 °C to 1350 °C ±2 °C Accuracy	30	12	0.22	0.25
		62 -	I					
		63 R	I					
		64 +	I					
		65 -	I					
		66 R	I					
OUTLET	NO	67 +	I	RTD Mode: PT-100 RTD -100 °C to 850 °C ±0.5 °C Accuracy	30	12	0.22	0.25
		68 -	I					
		69 R	I					
STACK	NO	70 +	I		30	12	0.22	0.25
		71 -	I					
SWITCH ⁵	YES	72 R	I	3.3V _{DC} max	30	12	0.22	0.25
		- RUN	I					
		- IGN	I					
		- PWR	O	3.3V _{DC} , 1kΩ source impedance				

¹ The Bath Temperature Input is safety rated ONLY if the input is configured as a Dual. If configured as a Single element the Bath temperature input is NOT safety rated.

² A digital input with an input current of 1.25mA or greater will be seen by the system as an energized input, while a digital input with an input current of 500µA or less will be seen by the system as a de-energized input.

³ Input accuracy when configured in 4-20mA mode: ±0.1 mA









⁴ All wire sizes listed indicate the size restrictions of the BMS connector only. All wires must be adequately sized for their respective current requirements in accordance with local electrical codes.

⁵ Ignition Switch contacts must (1) be connected to a pre-wired, Profire-supplied PF2200 ignition switch (Part No. PFA-004260) or (2) have RUN and PWR terminals connected with a wire jumper.

3 USER INTERFACE CARD

The User Interface Card allows interaction with the system through the use of the keypad, display, Modbus port, and USB port. The card interacts with the BMS card through a proprietary communication protocol called PFN, which utilizes the RS-485 physical transport layer. PFN and power to the User Interface are factory wired to the BMS card through a wiring harness.

3.1 KEYPAD

Button	Functions
	Start the system or individual burners from the Ready state
	Stop the system or individual burners while running ¹
	Return to previous screen from an on-screen menu
	Cycle through Status, Settings and System screens
	Display keypad functionality help screen
	Switch to Commissioner Mode to see all available settings Switch to Operator Mode to see only essential settings and setpoints
	Navigate Menus and highlight items
	Select highlighted item Open settings adjustment dialog when highlighting numeric settings
	Change Status screen display mode Make incremental changes to numeric settings Scroll Event Log by full page

¹The keypad is intended to aid in commissioning and system navigation, and it must not be incorporated into any safety function. If user shut-down is a required safety function, then the BMS Card ESD input or External Ignition Switch must be used.

Use the Keypad Diagnostic Tool (System > Diagnostics > Keypad) to check the functionality of each button individually.

3.2 CONTROLLER INTERFACE

The PF2200-DB controller consists of 3 main screens:

1. Status Screen – Always-on display that shows real-time system data including input device readings, individual burner state and alerts
2. Settings Screen – Screen containing all the configuration settings required to set up the system
3. System Screen – Screen containing tools for data logging and settings backup as well as a suite of diagnostic information for troubleshooting

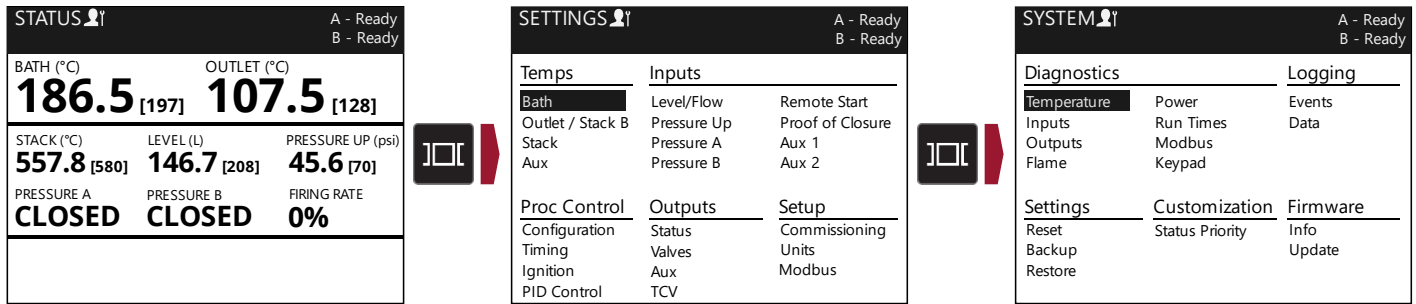

3.2.1 STATUS SCREEN

The Status Screen displays the current state of each burner in the Status Bar at the top of the Status Screen. All current alarms, waits, warnings, and main permissives are displayed in the Alerts Pane at the bottom of the Status Screen. The main window of the Status Screen shows the current states/readings of the connected input devices.

The information displayed can be customized to show one, five, or eight status elements; use **+** and **-** to cycle between the one-item, five-item, and eight-item zoom levels. The order in which the status elements are displayed on each zoom level can be customized using the Status Priority Tool (System > Customization > Status Priority).

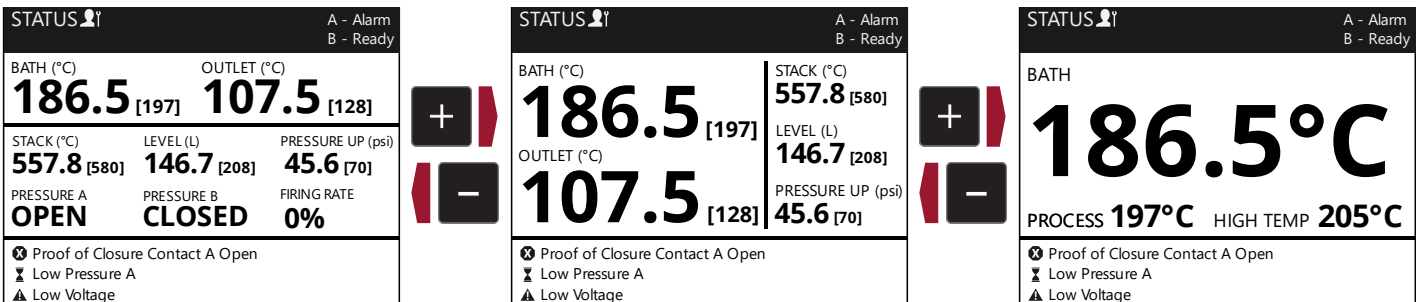

3.2.2 SETTINGS SCREEN

The Settings Screen contains sub-menus for all configuration settings required to commission a system. Use **◀ ▶ ▾ ▹** to select a menu and press **OK** to see a list of all related settings. By default, the Settings Screen is shown in Operator Mode, so a limited number of settings are displayed for quickly making changes after the system has been commissioned. Pressing **F1** will switch to Commissioning Mode and read-only access will be granted to all settings. Users must enter a valid password when prompted in order to modify settings.

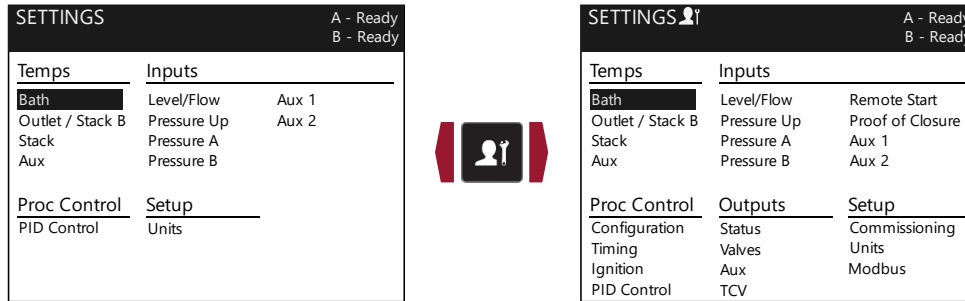

SETTINGS MODIFICATION

A valid password must be entered when prompted in order to adjust any setting. Each setting has a pre-determined security level based on its potential safety and reliability impact, and each security level has a separate password.

- L1 security level: settings that DO NOT impact the safety-integrity of the system BUT can impact the process operation.

If the **L1 Password Enable** setting is **Enabled**, L1 setting modification requires the L1 password. If the **L1 Password Enable** setting is **Disabled**, L1 settings can be modified with no password.

- L2 security level: settings that DO impact the safety-integrity of the system

For L1 and L2 passwords, please contact Profire customer service. Passwords will only be distributed to individuals that are capable of assessing the safety impact of the changes they intend to make.

After entering a valid password, the user is authenticated and can make changes to the associated settings. The authentication will timeout after 15 minutes regardless of activity. Any further attempt to adjust settings requires the user to re-authenticate.

There are two different types of settings that can be configured: Settings in a drop-down menu and numeric settings.

Setting Type	Quick Settings Adjustment Method	Accepted Change Method
Drop-down menu options	<ol style="list-style-type: none"> 1. Highlight drop down menu 2. Use + and - to cycle through options 	<ol style="list-style-type: none"> 1. Highlight drop-down menu 2. Press OK to display the full list of options 3. Use ▲ and ▼ to select desired option 4. Press OK to accept change
Numeric settings	<ol style="list-style-type: none"> 1. Highlight setting 2. Use + and - to change value incrementally 	<ol style="list-style-type: none"> 1. Highlight setting 2. Press OK to open settings modification dialog 3. Use ◀ and ▶ to select digit to change 4. Use + and - to change selected digit 5. Select Accept and press OK to save the change

Settings changes made using the Quick Settings Adjustment methods take effect immediately when changed. Settings changes made using the Accepted Change method do not take effect until after the change has been accepted by the user. When using the accepted change method, pressing **⇒** will discard a change that has not yet been accepted by the user.

3.2.3 SYSTEM SCREEN

The PF2200 System Screen contains tools for system monitoring, troubleshooting, and customization. The diagnostics menus contain useful real-time troubleshooting information, the logging tools provide detailed event history and data logging functionality, the settings tools allow saving and loading of settings between controllers, and the status priority tool allows for customization of the information displayed on the Status screen.

DIAGNOSTICS

Menu Item	Description
Temperature Diagnostics	Displays real-time temperature readings of all temperature inputs and ambient temperature sensors.
Input Diagnostics	Displays real-time external switch position and voltage or current readings of all BMS inputs.
Output Diagnostics	Displays real-time TCV output positions and power consumption readings for all solenoid outputs.
Flame Diagnostics	Displays real-time flame strength information, flame fails since last power cycle and allowable relights remaining.
Power Diagnostics	Displays real-time and average hourly power consumption readings.
Run Times	Displays system and valve run times since last power cycle.
Modbus Diagnostics	Displays Modbus transmission statistics, error counts and key troubleshooting information.
Keypad Diagnostics	Interactive tool for testing the functionality of each key on the keypad.

LOGGING

EVENT LOG

The Event Log screen displays a full history of system events for reference and troubleshooting. Events are continuously recorded to the USB storage device when inserted.

The event log displays all events that are stored on the USB storage device. If no USB is installed, the system only displays a limited number of past events and gets cleared upon power cycle. When the USB device is full, the oldest event will be deleted to make room for a new event to be logged.

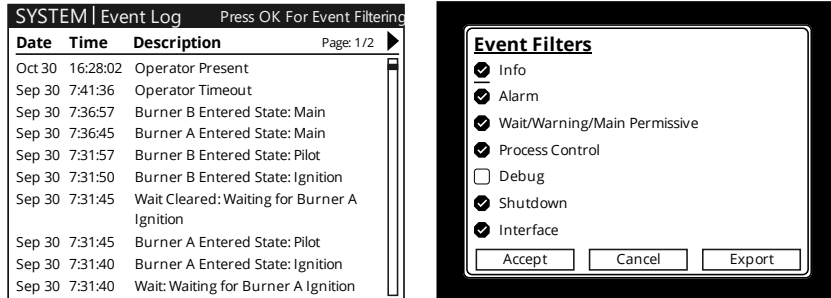

Use the event log filter to view specific events on the system screen. All event types will still be logged to the USB storage device, regardless of the filters selected.

DATA LOGGING

The Data Logging tool logs input/output readings for up to 8 user selectable pieces of system information to the USB storage device. The data is logged in 15 second intervals and saved to the USB storage device regularly.

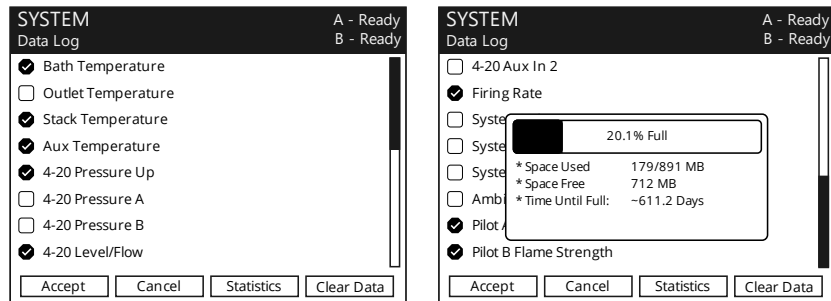

Use the Data Log Statistics window to see an estimate of how long the system will run before the USB storage device becomes full. Once full, the oldest data will be deleted and replaced with new data.

SETTINGS

Menu Item	Description
Reset	Resets all BMS settings to their default values.
Backup	Saves all current BMS settings to the USB storage device.
Restore	Tool to load BMS settings from the USB storage device.

Some settings may not be restored when loading a settings file from a system with a different version of firmware installed. The settings restore tool provides a list of all settings that were not restored. Ensure that all settings are correct after using the Settings Restore tool.

STATUS PRIORITY

The Status Priority tool allows configuration of the items displayed on the main Status screen. Use **▲** and **▼** to select a status element and **+** and **-** to move it up or down the priority list.

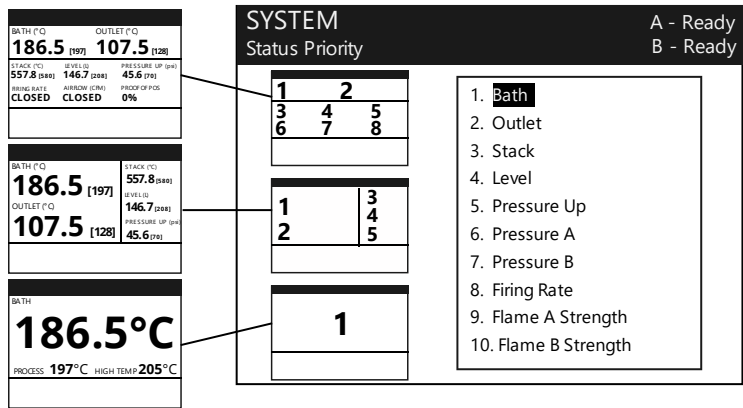

The images on the Status Priority screen represent the Status screen and show how the status elements will be displayed in the one, five, or eight element Status screen views.

FIRMWARE

INFORMATION

The Information screen shows displays useful firmware and hardware information associated with the BMS and UI cards.

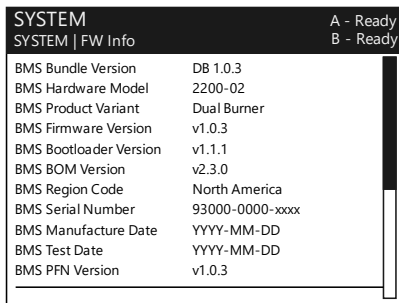

It is useful to have this system information on hand when contacting Profire for technical support.

3.3 STATUS LED

The LED on the front of the PF2200-DB indicates the current operating state of the system.

3.3.1 STATUS LED BEHAVIOR

Burner A State	Burner B State	Condition	Behavior
Power On	Power On	Any	Green-Amber-Red
Alarm	Alarm	Any	Slow blinking Red
Ready	Ready	Any	Solid Red
Lockout	Any stopped state	Any	Fast flashing Red
Any stopped state	Lockout	Any	
Lockout	Any running state	Any	Fast alternating Green and red
Any running state	Lockout	Any	
Any running state	Alarm	Any	Slow alternating Green and Red
Alarm	Any running state	Any	
Any running state	Ready	Any	Slow alternating Green and Amber
Ready	Any running state	Any	
Any running state	Any running state	No waits present ¹	Solid Green
		No warnings present	Slow blinking Green
		Wait present ¹	
		No warnings present	Slow blinking Amber
		Wait present ¹	
		Warning present	Solid Amber

¹ With the exception of Waiting on High Process Temp.

3.4 MODBUS COMMUNICATION

Remote access to status information and non-safety critical settings is available via the Modbus terminals on the UI card. Refer to the PF2200-DB Modbus Configuration Guide for detailed programming information.

3.4.1 INTENDED FIELD DEVICE CONNECTIONS

Field Device	Configuration Requirements	Connection Diagrams
Modbus Communication Module -Terminating resistor not required	Settings > Setup > Modbus Modbus RTU Communication: Enabled Modbus Termination: Disabled All other settings: As desired	Modbus Input Wiring
Modbus Communication Module -Terminating resistor required	Settings > Setup > Modbus Modbus RTU Communication: Enabled Modbus Termination: Enabled All other settings: As desired	Modbus Input Wiring
Not Used	Settings > Setup > Modbus Modbus RTU Communication: Disabled	N/A

Navigate to the Modbus Diagnostics Screen (System > Diagnostics > Modbus) for useful Modbus troubleshooting information.

3.5 USB PORT

The USB port of the User Interface card is used for data-logging as well as settings backup and restore functionality.

3.5.1 USB FUNCTIONS

Function	Configuration Requirements
Event logging to USB	System > Logging > Events No configuration required - Event log is automatically stored to USB when installed
Data logging to USB	System > Logging > Data Select up to 8 items to log
Saving current controller settings to USB	System > Settings > Backup
Loading saved controller settings from USB	System > Settings > Restore Select desired file to load

An approved USB storage device must be used; use of a non-approved USB storage device may compromise USB functionality. Each PF2200 is shipped with one approved USB storage device. Please contact Profire for replacements.

4 BMS CARD

The BMS card provides the necessary inputs and outputs to safely control two burners in a single appliance as well as additional inputs and outputs to reliably accommodate a variety of dual burner applications. The following section outlines the behavior and intended device connections for each BMS input and output and provides brief configuration instructions and links to the appropriate [Connection Diagrams](#).

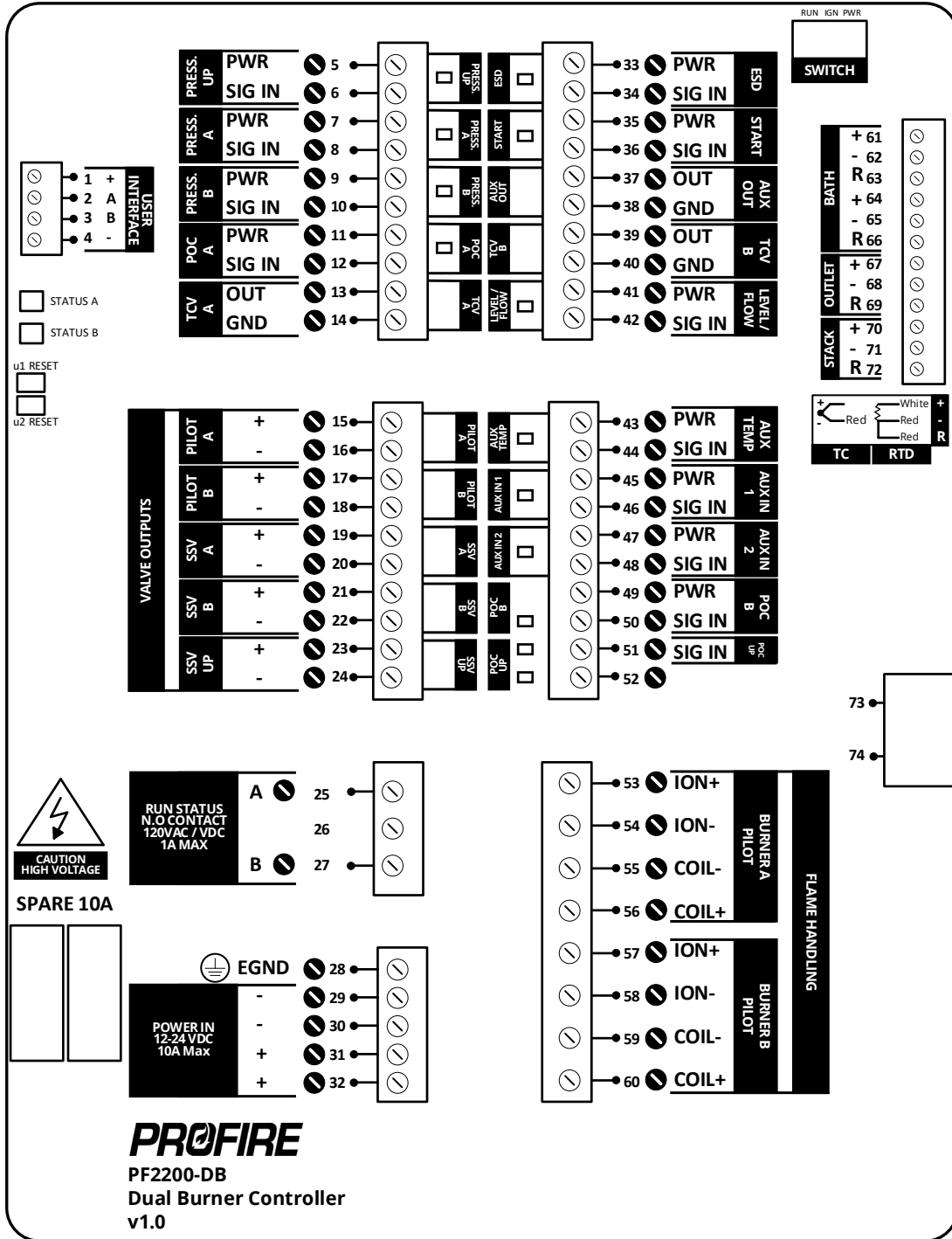

4.1 UPSTREAM PRESSURE INPUT

4.1.1 DETAILS

Item	
Terminals	5 & 6
Name	PRESS. UP
Type	Configurable digital or 4-20mA input
Burners affected	Burner A and Burner B

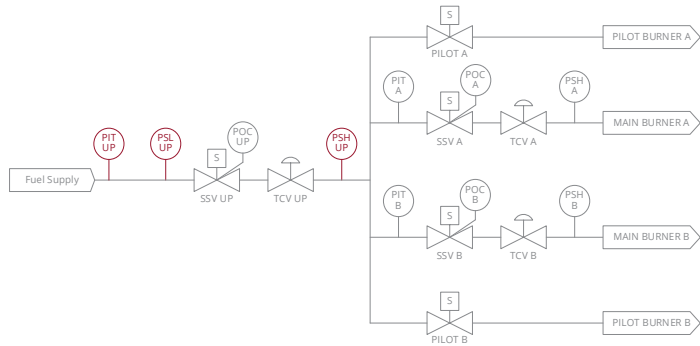

4.1.2 INTENDED FIELD DEVICE CONNECTIONS

Field Device	Configuration Requirements	Connection Diagrams
Upstream 4-20mA pressure transmitter	Settings > Inputs > Pressure Up Type: 4-20 Digital Type: Ignored Span Min/Max: transmitter Min/Max All other settings: As desired Settings > Setup > Units Pressure: As desired System > Customization > Status Priority As desired	Analog Input – Loop Powered 4-20mA Transmitter Analog Input – Self Powered 4-20mA Transmitter
Upstream low-pressure switch	Settings > Inputs > Pressure Up Type: Digital Low Pressure Mode: As desired All other settings: Ignored System > Customization > Status Priority As desired	Digital Input – Dry Contact Digital Input – Wet Contact
Upstream high-pressure switch	Settings > Inputs > Pressure Up Type: Digital All other settings: Ignored System > Customization > Status Priority As desired	Digital Input – Dry Contact Digital Input – Wet Contact
Not Used	Settings > Inputs > Pressure Up Type: Disabled	N/A

The Upstream Pressure input is a shared appliance input that affects the behavior of Burner A and Burner B identically.

4.1.3 SYSTEM BEHAVIOR – 4-20mA PRESSURE TRANSMITTER

Low Pressure Mode Setting	Scenario		Burner A Transition	Burner B Transition	Alerts Pane
	Press. Up Input	Burner State			
Any	Out of Range	Running	Lockout	Lockout	Upstream Pressure Out of Range Alarm
		Stopped	Alarm	Alarm	Upstream Pressure Out of Range Alarm
Alarm	High Trip	Main fuel state	Lockout	Lockout	High Upstream Pressure Alarm
		Not a main fuel state	No effect	No effect	High Upstream Pressure Warning
Wait	Low Trip	Running	Lockout	Lockout	Low Upstream Pressure Alarm
		Stopped	Alarm	Alarm	Low Upstream Pressure Alarm
Warning	Low Trip	Running	Waiting	Waiting	Low Upstream Pressure Wait
		Stopped	No effect	No effect	Low Upstream Pressure Wait
Main Permissive	Low Trip	Any	No effect	No effect	Low Upstream Pressure Warning
		Main fuel state	Pilot	Pilot	Low Upstream Pressure Main Permissive
		Not a main fuel state	No effect	No effect	Low Upstream Pressure Main Permissive

4.1.4 SYSTEM BEHAVIOR – DIGITAL LOW-PRESSURE SWITCH

Low Pressure Mode Setting	Scenario		Burner A Transition	Burner B Transition	Alerts Pane
	Press. Up Input	Burner State			
Any	Energized	Any	No effect	No effect	N/A
Alarm	De-energized	Running	Lockout	Lockout	Low Upstream Pressure Alarm
		Stopped	Alarm	Alarm	Low Upstream Pressure Alarm
Wait	De-energized	Running	Waiting	Waiting	Low Upstream Pressure Wait
		Stopped	No effect	No effect	Low Upstream Pressure Wait
Warning	De-energized	Any	No effect	No effect	Low Upstream Pressure Warning
Main Permissive	De-energized	Main fuel state	Pilot	Pilot	Low Upstream Pressure Main Permissive
		Not a main fuel state	No effect	No effect	Low Upstream Pressure Main Permissive

4.1.5 SYSTEM BEHAVIOR – DIGITAL HIGH-PRESSURE SWITCH

Low Pressure Mode Setting	Scenario		Burner A Transition	Burner B Transition	Alerts Pane
	Press. Up Input	Burner State			
Ignored	Energized	Any	No effect	No Effect	N/A
	De-energized	Main fuel state	Lockout	Lockout	High Upstream Pressure Alarm
	De-energized	Not a main fuel state	No effect	No effect	High Upstream Pressure Warning

4.2 BURNER A PRESSURE INPUT

4.2.1 DETAILS

Item	
Terminals	7 & 8
Name	PRESS A
Type	Configurable Digital or 4-20mA Input
Burners Affected	Burner A only

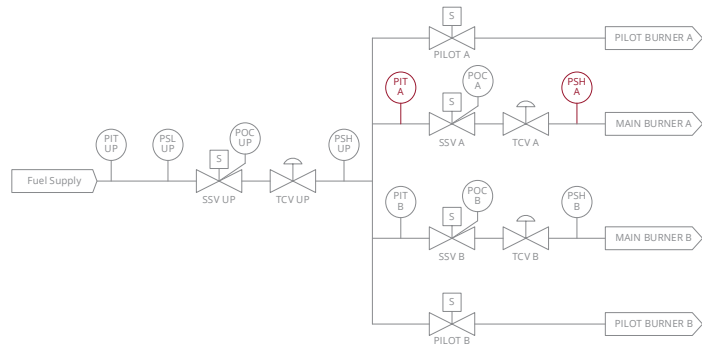

4.2.2 INTENDED FIELD DEVICE CONNECTIONS

Field Device	Configuration Requirements	Connection Diagrams
Burner A 4-20mA pressure transmitter	Settings > Inputs > Pressure A Type: 4-20 Span Min/Max: transmitter Min/Max All other settings: As desired Settings > Setup > Units Pressure: As desired System > Customization > Status Priority As desired	Analog Input - Loop Powered 4-20mA Transmitter Analog Input - Self Powered 4-20mA Transmitter
Burner A digital high-pressure switch	Settings > Inputs > Pressure A Type: Digital All other settings: Ignored System > Customization > Status Priority As desired	Digital Input - Dry Contact Digital Input - Wet Contact
Not Used	Settings > Inputs > Pressure A Type: Disabled	N/A

4.2.3 SYSTEM BEHAVIOR - 4-20mA PRESSURE TRANSMITTER

Low Pressure Mode Setting	Scenario	Burner A Transition	Burner B Transition	Alerts Pane	
				Press. A Input	Burner State
Any	Out of Range	Running	Lockout	Lockout	Pressure A Out of Range Alarm
		Stopped	Alarm	Alarm	Pressure A Out of Range Alarm
Alarm	High Trip	Main fuel state	Lockout	No effect	High Pressure A Alarm
		Not a main fuel state	No effect	No effect	High Pressure A Warning
Wait	Low Trip	Running	Lockout	No effect	Low Pressure A Alarm
		Stopped	Alarm	No effect	Low Pressure A Alarm
Warning	Low Trip	Running	Waiting	No effect	Low Pressure A Wait
		Stopped	No effect	No effect	Low Pressure A Wait
Main Permissive	Low Trip	Any	No effect	No effect	Low Pressure A Warning
		Main fuel state	Pilot	No effect	Low Pressure A Main Permissive
		Not a main fuel state	No effect	No effect	Low Pressure A Main Permissive

4.2.4 SYSTEM BEHAVIOR - DIGITAL HIGH-PRESSURE SWITCH

Low Pressure Mode Setting	Scenario	Burner A Transition	Burner B Transition	Alerts Pane	
				Press. A Input	Burner State
Ignored	De-energized	Any	No effect	No effect	N/A
		Main fuels state	Lockout	No effect	High Pressure A Alarm
		Not a main fuel state	No effect	No effect	High Pressure A Warning

4.3 BURNER B PRESSURE INPUT

4.3.1 DETAILS

Item	
Terminals	9 & 10
Name	PRESS B
Type	Configurable Digital or 4-20mA Input
Burners Affected	Burner B only

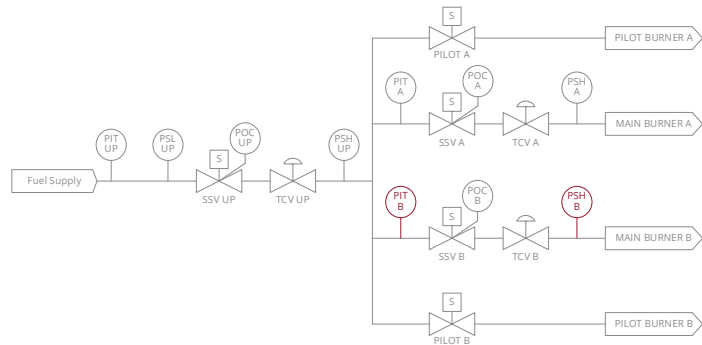

4.3.2 INTENDED FIELD DEVICE CONNECTIONS

Field Device	Configuration Requirements	Connection Diagrams
Burner B 4-20mA pressure transmitter	Settings > Inputs > Pressure B Type: 4-20 Span Min/Max: transmitter Min/Max All other settings: As desired Settings > Setup > Units Pressure: As desired System > Customization > Status Priority As desired	Analog Input - Loop Powered 4-20mA Transmitter Analog Input - Self Powered 4-20mA Transmitter
Burner B digital high-pressure switch	Settings > Inputs > Pressure B Type: Digital All other settings: Ignored System > Customization > Status Priority As desired	Digital Input - Dry Contact Digital Input - Wet Contact
Not Used	Settings > Inputs > Pressure B Type: Disabled	N/A

4.3.3 SYSTEM BEHAVIOR - 4-20mA PRESSURE TRANSMITTER

Low Pressure Mode Setting	Scenario	Burner A Transition	Burner B Transition	Alerts Pane	
				Press. B Input	Burner State
Any	Out of Range	Running	Lockout	Lockout	Pressure B Out of Range Alarm
		Stopped	Alarm	Alarm	Pressure B Out of Range Alarm
Alarm	High Trip	Main fuel state	No effect	Lockout	High Pressure B Alarm
		Not a main fuel state	No effect	No effect	High Pressure B Warning
Wait	Low Trip	Running	No effect	Lockout	Low Pressure B Alarm
		Stopped	No effect	Alarm	Low Pressure B Alarm
Warning	Low Trip	Running	No effect	Waiting	Low Pressure B Wait
		Stopped	No effect	No effect	Low Pressure B Wait
Main Permissive	Low Trip	Any	No effect	No effect	Low Pressure B Warning
		Main fuel state	No effect	Pilot	Low Pressure B Main Permissive
		Not a main fuel state	No effect	No effect	Low Pressure B Main Permissive

4.3.4 SYSTEM BEHAVIOR - DIGITAL HIGH-PRESSURE SWITCH

Low Pressure Mode Setting	Scenario	Burner A Transition	Burner B Transition	Alerts Pane	
				Press. B Input	Burner State
Ignored	De-energized	Any	No effect	No effect	N/A
		Main fuels state	No effect	Lockout	High Pressure B Alarm
		Not a main fuel state	No effect	No effect	High Pressure B Warning

4.4 BURNER A PROOF OF CLOSURE INPUT

4.4.1 DETAILS

Item	
Terminals	11 & 12
Name	POC A
Type	Digital input
Burners Affected	Burner A only

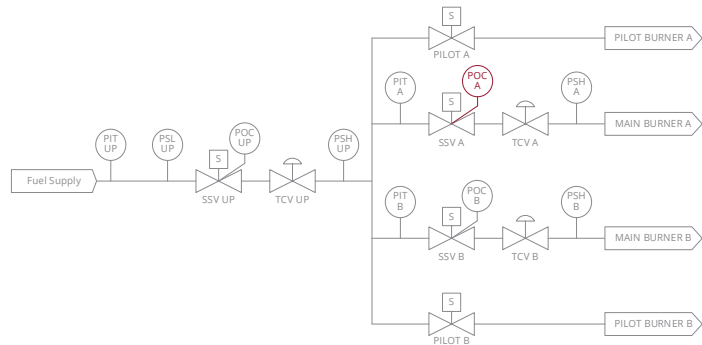

4.4.2 INTENDED FIELD DEVICE CONNECTIONS

Field Device	Configuration Requirements	Connection Diagrams
Burner A Main Valve (SSV A) Proof of Closure Switch	Settings > Inputs > Proof of Closure Proof of Closure A: Enabled	Digital Input – Dry Contact Digital Input – Wet Contact
Not Used	Settings > Inputs > Proof of Closure Proof of Closure A: Disabled	N/A

4.4.3 SYSTEM BEHAVIOR

POC A Setting	Scenario	Burner A Transition	Burner B Transition	Alerts Pane
Energized	Main fuel state	No effect	No effect	Proof of Closure A Failed to Open Warning
	Not a main fuel state	No effect	No effect	N/A
Enabled	Main fuel state	No effect	No effect	N/A
	Running – not a main fuel state	Lockout	No effect	Proof of Closure Contact A Open Alarm
De-energized	Stopped	Alarm	No effect	Proof of Closure Contact A Open Alarm
	Any	Any	No effect	No effect

4.5 BURNER A TEMPERATURE CONTROL VALVE OUTPUT

4.5.1 DETAILS

Item	
Terminals	13 & 14
Name	TCV A
Type	4-20mA output

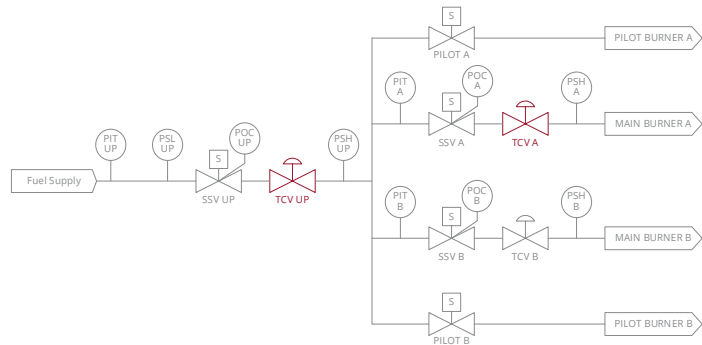

4.5.2 INTENDED FIELD DEVICE CONNECTIONS

Field Device	Configuration Requirements	Connection Diagrams
Upstream 4-20mA Proportional Fuel Gas Valve using internal PID algorithm	Settings > Outputs > TCV Shared TCV (A): Enabled All other settings: As desired Settings > Proc Control > Configuration Process Control Mode: PID Control Settings > Proc Control > PID Control All settings: As desired	TCV Output Wiring
Upstream 4-20mA Proportional Fuel Gas Valve using external firing rate signal	Settings > Outputs > TCV Shared TCV (A): Enabled All other settings: As desired Settings > Proc Control > Configuration Process Control Mode: Firing Rate Settings > Inputs > Aux 1 or Aux 2 Configure as a 4-20mA Appliance Firing Rate input	TCV Output Wiring
Burner A 4-20mA Proportional Fuel Gas Valve using internal PID algorithm	Settings > Outputs > TCV Shared TCV (A); Disabled All other settings: As desired Settings > Proc Control > Configuration Process Control Mode: PID Control Settings > Proc Control > PID Control All settings: As desired	TCV Output Wiring
Burner A 4-20mA Proportional Fuel Gas Valve using external firing rate signal	Settings > Outputs > TCV Shared TCV (A): Disabled All other settings: As desired Settings > Proc Control > Configuration Process Control Mode: Firing Rate Settings > Inputs > Aux 1 or Aux 2 Configure as a 4-20mA Appliance Firing Rate input	TCV Output Wiring
Not Used	N/A	N/A

4.5.3 SYSTEM BEHAVIOR

Shared TCV		Scenario		
Setting	Burner A State	Burner B State	TCV A Output Position	
Disabled	Any stopped state	Any	Purge Position	
	Waiting	Any	Purge Position	
	Ignition	Any	Pilot Position	
	Pilot	Any	Pilot Position	
	Main Light Off	Any	Min Position	
	Process Control – Main	Any	100%	
	Process Control – PID Control	Any	Between Minimum Position and 100% per configured PID Control settings	
	Process Control – External Firing Rate	Any	Between Minimum Position and 100% per appliance firing rate input	
	Enabled	Any non-fuel state	Any non-fuel state	Purge Position
Ignition or Pilot		Any non-fuel state while system purging	Purge Position	
Any non-fuel state while system purging		Ignition or Pilot	Purge Position	
Ignition or Pilot		Any non-fuel state while system not purging	Pilot Position	
Any non-fuel state while system not purging		Ignition or Pilot	Pilot Position	
Process Control – Main		Any state other than Main Light Off	100%	
Process Control – PID Control		Any state other than Main Light Off	Between Minimum Position and 100% per internal PID algorithm	
Process Control – External Firing Rate		Any state other than Main Light Off	Between Minimum Position and 100% per appliance firing rate input	
Any Process Control		Main Light Off		Minimum Position
		Process Control – Main		100%
Any state other than Main Light Off		Process Control – PID Control		Between Minimum Position and 100% per configured PID Control settings
		Process Control – External Firing Rate		Between Minimum Position and 100% per appliance firing rate input
Main Light Off		Any Process Control		Minimum Position

When the TCV **Manual Override** setting is **Enabled** the TCV A output will match the configured TCV **Manual Position** setting regardless of burner state.

4.6 BURNER A PILOT VALVE SOLENOID OUTPUT

4.6.1 DETAILS

Item	
Terminals	15 & 16
Name	PILOT A
Type	Powered solenoid valve output with configurable PWM

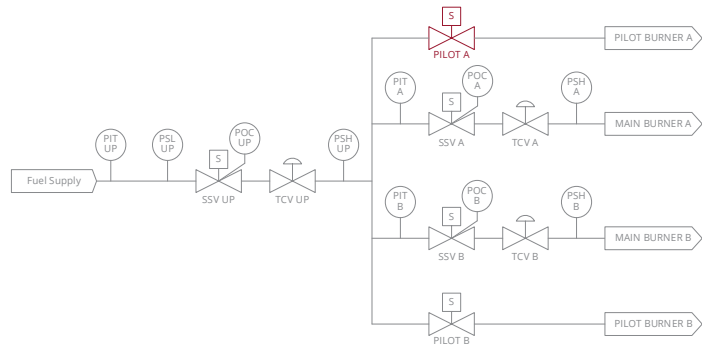

4.6.2 INTENDED FIELD DEVICE CONNECTIONS

Field Device	Configuration Requirements	Connection Diagrams
Burner A Normally Closed Pilot Gas Shutoff Valve – Peak and Hold	Settings > Proc Control > Configuration Pilot Off Mode: As desired Minimum Pilots Running: As desired Settings > Proc Control > Timing Pilot Startup Delay Time: As desired Settings > Outputs > Valves Pilot Valve A PWM: As desired	Solenoid Output – 12V/24V
Burner A Normally Closed Pilot Gas Shutoff Valve – Constant current	Settings > Proc Control > Configuration Pilot Off Mode: As desired Minimum Pilots Running: As desired Settings > Proc Control > Timing Pilot Startup Delay Time: As desired Settings > Outputs > Valves Pilot Valve A PWM: 100%	Solenoid Output – 12V/24V

4.6.3 SYSTEM BEHAVIOR

Burner A State	Pilot A Output
Any stopped state	De-energized
Waiting	De-energized
Ignition	Energized
Pilot	Energized
Main Light Off	Energized
Process Control	Energized

4.7 BURNER B PILOT VALVE SOLENOID OUTPUT

4.7.1 DETAILS

Item	
Terminals	17 & 18
Name	PILOT B
Type	Powered solenoid valve output with configurable PWM

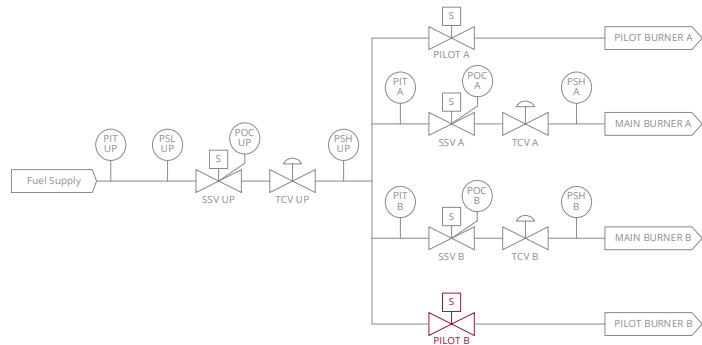

4.7.2 INTENDED FIELD DEVICE CONNECTIONS

Field Device	Configuration Requirements	Connection Diagrams
Burner B Normally Closed Pilot Gas Shutoff Valve – Peak and Hold	Settings > Proc Control > Configuration Pilot Off Mode: As desired Minimum Pilots Running: As desired Settings > Outputs > Valves Pilot Valve B PWM: As desired	Solenoid Output – 12V/24V
Burner B Normally Closed Pilot Gas Shutoff Valve – Constant current	Settings > Proc Control > Configuration Pilot Off Mode: As desired Minimum Pilots Running: As desired Settings > Outputs > Valves Pilot Valve B PWM: 100%	Solenoid Output – 12V/24V

4.7.3 SYSTEM BEHAVIOR

Burner B State	Pilot B Output
Any stopped state	De-energized
Waiting	De-energized
Ignition	Energized
Pilot	Energized
Main Light Off	Energized
Process Control	Energized

4.8 BURNER A MAIN VALVE SOLENOID OUTPUT

4.8.1 DETAILS

Item	
Terminals	19 & 20
Name	SSV A
Type	Powered solenoid valve output with configurable PWM

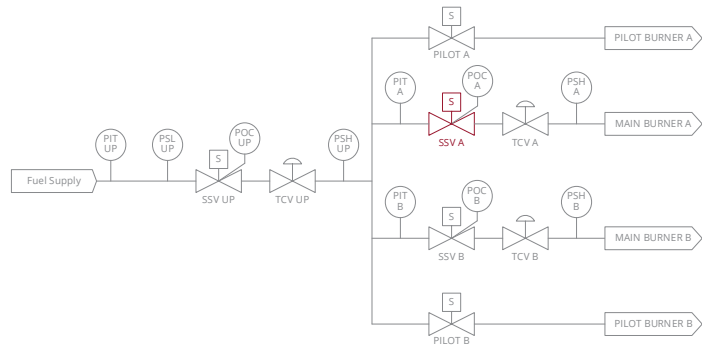

4.8.2 INTENDED FIELD DEVICE CONNECTIONS

Field Device	Configuration Requirements	Connection Diagrams
Burner A Normally Closed Main Gas Shutoff Valves – Peak and Hold	Settings > Outputs > Valves SSV A PWM: As desired	Solenoid Output – 12V/24V
Burner A Normally Closed Main Gas Shutoff Valves – Constant current	Settings > Outputs > Valves SSV A PWM: 100%	Solenoid Output – 12V/24V

4.8.3 SYSTEM BEHAVIOR

Burner A State	SSV A Output
Power On	De-energized
Lockout	De-energized
Alarm	De-energized
Ready	De-energized
Waiting	De-energized
Ignition	De-energized
Pilot	De-energized
Main Light Off	Energized
Process Control	Energized

4.9 BURNER B MAIN VALVE SOLENOID OUTPUT

4.9.1 DETAILS

Item	
Terminals	21 & 22
Name	SSV B
Type	Powered solenoid valve output with configurable PWM

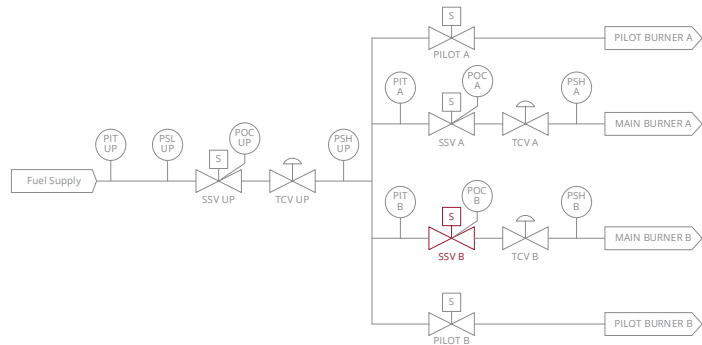

4.9.2 INTENDED FIELD DEVICE CONNECTIONS

Field Device	Configuration Requirements	Connection Diagrams
Burner B Normally Closed Main Gas Shutoff Valves – Peak and Hold	Settings > Outputs > Valves SSV B PWM: As desired	Solenoid Output – 12V/24V
Burner B Normally Closed Main Gas Shutoff Valves – Constant current	Settings > Outputs > Valves SSV B PWM: 100%	Solenoid Output – 12V/24V

4.9.3 SYSTEM BEHAVIOR

Burner B State	SSV B Output
Power On	De-energized
Lockout	De-energized
Alarm	De-energized
Ready	De-energized
Waiting	De-energized
Ignition	De-energized
Pilot	De-energized
Main Light Off	Energized
Process Control	Energized

4.10 UPSTREAM MAIN SOLENOID VALVE OUTPUT

4.10.1 DETAILS

Item	
Terminals	23 & 24
Name	SSV UP
Type	Powered solenoid valve output with configurable PWM

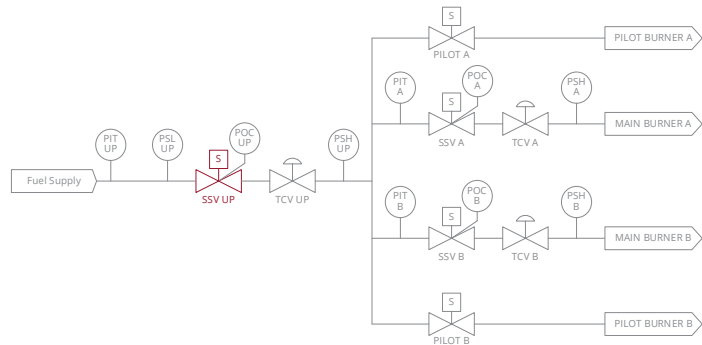

4.10.2 INTENDED FIELD DEVICE CONNECTIONS

Field Device	Configuration Requirements	Connection Diagrams
Upstream Normally Closed Main Gas Shutoff Valves – Peak and Hold	Settings > Proc Control > Configuration Minimum Pilots Running: As desired Settings > Outputs > Valves SSV Upstream PWM: As desired	Solenoid Output – 12V/24V
Upstream Normally Closed Main Gas Shutoff Valves – Constant current	Settings > Proc Control > Configuration Minimum Pilots Running: As desired Settings > Outputs > Valves SSV Upstream PWM: 100%	Solenoid Output – 12V/24V

4.10.3 SYSTEM BEHAVIOR

Minimum Pilots Running Setting	Burner A State	Burner B State	SSV Up Output
1	Main fuel state	Any	Energized
	Any	Main fuel state	Energized
	Not a main fuel state	Not a main fuel state	De-energized
2	Main fuel state	Main fuel state	Energized
	Not a main fuel state	Any	De-energized
	Any	Not a main fuel state	De-energized

The **Minimum Burners Running** setting must be set to **2** if the Upstream SSV is being used as a safety shutoff. This will cause both SSV A and SSV B outputs as well as the SSV Up output to de-energize in the event of a system shutdown.

4.11 STATUS CONTACT

4.11.1 DETAILS

Item	
Terminals	25 & 27
Name	RUN STATUS
Type	Normally open dry contact

4.11.2 INTENDED FIELD DEVICE CONNECTIONS

Field Device	Configuration Requirements	Connection Diagrams
Site equipment status panel	Settings > Outputs > Status Mode: As desired	Run Status – External AC Source Run Status – External DC Source Run Status – BMS Power
Tank pump motor enable via relay	Settings > Outputs > Status Mode: Level/Flow Control Settings > Inputs > Level/Flow Type: 4-20 4-20 High Trip Setpoint: As desired 4-20 Deadband: As desired 4-20 Span Min/Max: per transmitter	Run Status – Pump Control

4.11.3 STATUS CONTACT BEHAVIOR – RUN STATUS MODE

Burner A State	Burner B State	Status Contact Behavior
Any stopped state	Any	De-energized
Any	Any stopped state	De-energized
Any running state	Any running state	Energized

4.11.4 STATUS CONTACT BEHAVIOR – HEATING STATUS MODE

Burner A State	Burner B State	Status Contact Behavior
Any fuel state	Any	Energized
Any	Any fuel state	Energized
Any non-fuel state	Any non-fuel state	De-energized

4.11.5 STATUS CONTACT BEHAVIOR – LOW TEMP WARNING MODE

Burner A State	Burner B State	Process Temp Reading	Status Contact Behavior
Any stopped state	Any	Below Low Temp Setpoint	De-energized
		Above Low Temp Setpoint	De-energized
Any	Any stopped state	Below Low Temp Setpoint	De-energized
		Above Low Temp Setpoint	De-energized
Any running state	Any running state	Below Low Temp Setpoint	De-energized
		Above Low Temp Setpoint	Energized

4.11.6 STATUS CONTACT BEHAVIOR – LEVEL/FLOW CONTROL MODE

Burner A State	Burner B State	4-20mA Level/Flow Input Reading	Status Contact Behavior
Any	Any	Below High Trip Setpoint	Energized
		Above High Trip Setpoint	De-energized ¹

¹ Status Contact will remain De-energized until the 4-20mA Level/Flow input reading drops below the configured **4-20 High Trip Setpoint** minus the configured **4-20 Deadband**.

4.12 CONTROLLER POWER INPUT

4.12.1 DETAILS

Item	
Terminals	28, 29, 30, 31, 32
Name	POWER IN
Type	BMS power input

4.12.2 INTENDED FIELD DEVICE CONNECTIONS

Field Device	Configuration Requirements	Connection Diagrams
12V Power Supply	Settings > Setup > Commissioning Voltage Setting: 12V	Power Input Wiring
24V Power Supply	Settings > Setup > Commissioning Voltage Setting: 24V	Power Input Wiring

Use the Power Diagnostics Screen (System > Diagnostics > Power) to see real time voltage and power consumption numbers.

4.13 EMERGENCY SHUTDOWN INPUT

4.13.1 DETAILS

Item	
Terminals	33 & 34
Name	ESD
Type	Digital input
Burners Affected	Burner A and Burner B

4.13.2 INTENDED FIELD DEVICE CONNECTIONS

Field Device	Configuration Requirements	Connection Diagrams
External Emergency Stop Pushbutton		Digital Input - Dry Contact
Shutdown signal from PLC	N/A - ESD Input is always enabled	Digital Input - Wet Contact
Plant ESD loop		

4.13.3 SYSTEM BEHAVIOR

ESD Input	Burner State	Burner A Transition	Burner B Transition	Alerts Pane
De-energized	Running	Lockout	Lockout	ESD Contact Open Alarm
	Stopped	Alarm	Alarm	ESD Contact Open Alarm
Energized	Any	No effect	No effect	N/A

4.14 REMOTE START INPUT

4.14.1 DETAILS

Item	
Terminals	35 & 36
Name	START
Type	Digital input
Burners Affected	Burner A and Burner B

4.14.2 INTENDED FIELD DEVICE CONNECTIONS

Field Device	Configuration Requirements	Connection Diagrams
Remote Control Panel BMS Start Switch	Settings > Inputs > Remote Start Remote Start: Enabled	Digital Input - Dry Contact Digital Input - Wet Contact
Start signal from PLC	Settings > Inputs > Remote Start Remote Start: Enabled	Digital Input - Wet Contact
Not Used	Settings > Inputs > Remote Start Remote Start: Disabled	N/A

4.14.3 SYSTEM BEHAVIOR

Start Input	Initial Burner State	Burner Transition	Alerts Pane
Energized	Any	No effect	N/A
	Any stopped	No effect	Start Contact Open Wait
De-energized	Any running	Waiting	Start Contact Open Wait
	Lockout	Ready	N/A
Energized to de-energized to energized	Alarm	No effect	N/A
	Ready	Startup	N/A
	Any running	Waiting	N/A

The Remote Start input affects each burner independently. Be aware that each burner will respond differently depending on its current state when using the Remote Start input to start burners and acknowledge lockout messages. For example, If Burner A is in the Lockout state and Burner B is in the Ready state, toggling the Remote Start input from energized to de-energized to energized will acknowledge the Burner A lockout message, but will also start Burner B. The UI keypad, External Ignition Switch and Modbus functionality can be used to acknowledge a lockout message without starting the other burner.

4.15 AUXILIARY OUTPUT

4.15.1 DETAILS

Item	
Terminals	37 & 38
Name	AUX OUT
Type	4-20mA output

4.15.2 INTENDED FIELD DEVICE CONNECTIONS

Field Device	Configuration Requirements	Connection Diagrams
BMS Temperature input echo to PLC	Settings > Outputs > Aux Mode: As desired Temp Echo Spans: As desired	Analog Output – 4-20mA echo to PLC
BMS input echo to PLC	Settings > Setup > Units Temperature: As desired	Analog Output – 4-20mA echo to PLC
Modbus Register Echo to PLC	Settings > Outputs > Aux Mode: Modbus Echo Temp Echo Spans: Ignored Settings > Setup > Modbus RTU Communication: Enabled All other settings: As desired Modbus Setup: Write desired value (x10) to <i>Remote Echo for Aux</i> Modbus register	Analog Output – 4-20mA echo to PLC

4.15.3 SYSTEM BEHAVIOR

Configuration Details	Aux Out Behavior	Example
Mode: Any Temperature Echo mode	Temperature input value is echoed out on the Aux Output as a 4-20mA signal mapped between the Temp Echo Span values	Settings > Outputs > Aux Mode: Bath Temp Echo Temp Echo Span Min (4mA): 0 °F Temp Echo Span Max (20mA): 100 °F Actual Bath Temperature: 50 °F Aux Output Value: 12mA
Mode: Any BMS input Echo mode	BMS input value is echoed out on the Aux Output as an identical 4-20mA signal	Settings > Outputs > Aux Mode: Level/Flow Echo Actual Level/Flow Input Value: 12mA Aux Output Value: 12mA
Mode: Modbus Echo	Value written to <i>Remote Echo for Aux</i> Modbus register is echoed out on the Aux Output as a 4-20mA signal mapped between 0 and 100%. Note: Written value is interpreted as 10x the intended echo value (i.e. value of 255 written to Modbus register corresponds to a 25.5% output)	Settings > Outputs > Aux Mode: Modbus Echo Settings > Setup > Modbus RTU Communication: Enabled Actual value written to <i>Remote Echo for Aux</i> Modbus register: 500 (50.0%) Aux Output Value: 12mA

Refer to PF2200-DB Modbus Configuration Guide detailed Modbus register information.

4.16 BURNER B TEMPERATURE CONTROL VALVE OUTPUT

4.16.1 DETAILS

Item

Terminals	39 & 40
Name	TCV B
Type	4-20mA output

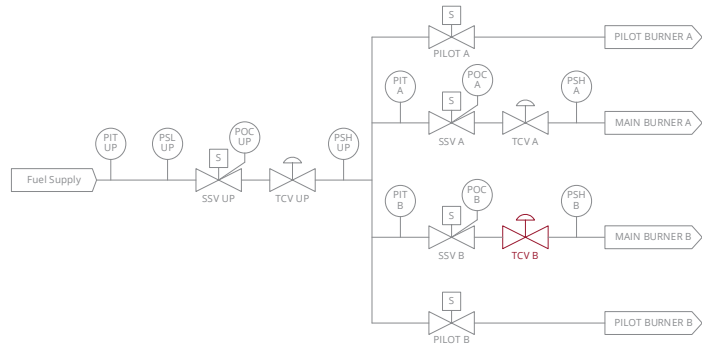

4.16.2 INTENDED FIELD DEVICE CONNECTIONS

Field Device	Configuration Requirements	Connection Diagrams
Burner B 4-20mA Proportional Fuel Gas Valve using internal PID algorithm	Settings > Outputs > TCV All settings: As desired Settings > Proc Control > Configuration Process Control Mode: PID Control Settings > Proc Control > PID Control All settings: As desired	TCV Output Wiring
Burner B 4-20mA Proportional Fuel Gas Valve using external firing rate input	Settings > Outputs > TCV All settings: As desired Settings > Proc Control > Configuration Process Control Mode: Firing Rate Settings > Inputs > Aux 1 or Aux 2 Configure as a 4-20mA Appliance Firing Rate input	TCV Output Wiring
Not Used	N/A	N/A

4.16.3 SYSTEM BEHAVIOR

Scenario		
Burner A State	Burner B State	TCV B Output Position
Any	Any stopped state	Purge Position
Any	Waiting	Purge Position
Any	Ignition	Pilot Position
Any	Pilot	Pilot Position
Any	Main Light Off	Min Position
Any	Process Control - Main	100%
Any	Process Control - PID Control	Between Minimum Position and 100% per configured PID Control settings
Any	Process Control - External Firing Rate	Between Minimum Position and 100% per external firing rate input

When the TCV **Manual Override** setting is **Enabled** the TCV B output will match the configured TCV **Manual Position** setting regardless of burner state.

4.17 LEVEL/FLOW INPUT

4.17.1 DETAILS

Item	
Terminals	41 & 42
Name	Level/Flow
Type	Configurable digital or 4-20mA input
Burners Affected	Burner A and Burner B

4.17.2 INTENDED FIELD DEVICE CONNECTIONS

Field Device	Configuration Requirements	Connection Diagrams
Digital level or flow switch	Settings > Inputs > Level/Flow Type: Digital Digital Mode: As desired Level/Flow Delay: As desired All other settings: Ignored System > Customization > Status Priority As desired	Digital Input - Dry Contact Digital Input - Wet Contact
4-20mA level or flow transmitter	Settings > Inputs > Level/Flow Type: 4-20 Digital Mode: Ignored Span Min/Max: Transmitter Min/Max All other settings: As desired Settings > Setup > Units Level/Flow: As desired System > Customization > Status Priority As desired	Analog Input - Loop Powered 4-20mA Transmitter Analog Input - Self Powered 4-20mA Transmitter
Not Used	Settings > Inputs > Level/Flow Type: Disabled	N/A

4.17.3 SYSTEM BEHAVIOR - DIGITAL LEVEL/FLOW SWITCH

Digital Mode Setting	Level/Flow Input	Scenario		Burner A Transition	Burner B Transition	Alerts Pane
		Burner State	Burner State			
Alarm	De-energized	Running	Running	Lockout	Lockout	Level/Flow Contact Open Alarm
		Stopped	Stopped	Alarm	Alarm	
Wait	De-energized	Running	Running	Waiting	Waiting	Level/Flow Contact Open Wait
		Stopped	Stopped	No effect	No effect	
Warning	De-energized	Any	Any	No effect	No effect	Level/Flow Contact Open Warning
		Any	Energized	Any	No effect	

4.17.4 SYSTEM BEHAVIOR - 4-20mA LEVEL/FLOW TRANSMITTER

Configuration Details	Level/Flow Input	Scenario		Burner A Transition	Burner B Transition	Alerts Pane
		Burner State	Burner State			
Any	Out of Range	Running	Running	Lockout	Lockout	Level/Flow Range Alarm
		Stopped	Stopped	Alarm	Alarm	
High Trip Mode: Alarm	High	Running	Running	Lockout	Lockout	High Level/Flow Alarm
		Stopped	Stopped	Alarm	Alarm	
High Trip Mode: Wait	High	Running	Running	Waiting	Waiting	High Level/Flow Wait
		Stopped	Stopped	No effect	No effect	
High Trip Mode: Warning	High	Any	Any	No effect	No effect	High Level/Flow Warning
Low Trip Mode: Alarm	Low	Running	Running	Lockout	Lockout	Low Level/Flow Alarm
		Stopped	Stopped	Alarm	Alarm	
Low Trip Mode: Wait	Low	Running	Running	Waiting	Waiting	Low Level/Flow Wait
		Stopped	Stopped	No effect	No effect	
Low Trip Mode: Warning	Low	Any	Any	No effect	No effect	Low Level/Flow Warning
Any	Valid Range	Any	Any	No effect	No effect	N/A

4.18 AUXILIARY TEMPERATURE INPUT

4.18.1 DETAILS

Item	
Terminals	43 & 44
Name	AUX TEMP
Type	4-20mA input
Burners Affected	Burner A and Burner B

4.18.2 INTENDED FIELD DEVICE CONNECTIONS

Field Device	Configuration Requirements	Connection Diagrams
4-20mA Primary Process Temperature Input	<p>Settings > Temps > Aux Mode: Process Control High Temp Setpoint: Per appliance safety requirements 4-20 Span Min/Max: Transmitter Min/Max All other settings: As desired</p> <p>Settings > Proc Control > Configuration Process Control Mode: Aux PID Control* Pilot Off Mode: As desired</p> <p>Settings > Setup > Units Temperature: As desired</p> <p>System > Customization > Status Priority As desired</p> <p>* If Process Control Mode is set to On/Off Control then Bath Mode (Settings > Temps > Bath) must be set to High Temp ESD</p>	<p>Analog Input - Loop Powered 4-20mA Transmitter Analog Input - Self Powered 4-20mA Transmitter</p>
4-20mA Secondary Process Temperature Input	<p>Settings > Temps > Aux Mode: Process Control High Temp Setpoint: Per appliance safety requirements 4-20 Span Min/Max: Transmitter Min/Max All other settings: As desired</p> <p>Settings > Proc Control > Configuration Process Control Mode: As desired Pilot Off Mode: As desired</p> <p>Settings > Setup > Units Temperature: As desired</p> <p>System > Customization > Status Priority As desired</p>	<p>Analog Input - Loop Powered 4-20mA Transmitter Analog Input - Self Powered 4-20mA Transmitter</p>
4-20mA High Temperature ESD Input	<p>Settings > Temps > Aux Mode: High Temp ESD High Temp Setpoint: As desired All other Setpoints: Ignored</p> <p>Settings > Setup > Units Temperature: As desired</p> <p>System > Customization > Status Priority As desired</p>	<p>Analog Input - Loop Powered 4-20mA Transmitter Analog Input - Self Powered 4-20mA Transmitter</p>
Display Only 4-20mA Temperature Input	<p>Settings > Temps > Aux Mode: Display Only All other Setpoints: Ignored</p> <p>Settings > Setup > Units Temperature: As desired</p> <p>System > Customization > Status Priority As desired</p>	<p>Analog Input - Loop Powered 4-20mA Transmitter Analog Input - Self Powered 4-20mA Transmitter</p>

4.18.3 SYSTEM BEHAVIOR

Aux Temperature Reading	Aux Temp Mode	Burner A Transition if running	Burner B Transition If running	Alerts Pane
Out of Range	Process Control	Lockout *	Lockout *	Aux Temp Out of Range Alarm
	High Temp ESD	Lockout *	Lockout *	Aux Temp Out of Range Alarm
	Display Only	No effect	No effect	Aux Temp Out of Range Warning
Above High Temp Setpoint	Disabled	No effect	No effect	N/A
	Process Control	Lockout *	Lockout *	High Aux Temp Alarm
	High Temp ESD	Lockout *	Lockout *	High Aux Temp Alarm
Below High Temp Setpoint and Above Low Temp Setpoint	Display Only	No effect	No effect	N/A
	Disabled	No effect	No effect	N/A
	Process Control	Refer to Operating Sequence Section for state specific behavior		
Below Low Temp Setpoint	High Temp ESD	No effect	No effect	N/A
	Display Only	No effect	No effect	N/A
	Disabled	No effect	No effect	N/A
	Process Control	No effect	No effect	Low Aux Temp Warning
	High Temp ESD	No effect	No effect	Low Aux Temp Warning
	Display Only	No effect	No effect	N/A
	Disabled	No effect	No effect	N/A

* Burner transition is to Alarm state rather than Lockout if not running

4.19 AUXILIARY INPUTS

4.19.1 DETAILS

Item	
Terminals	45 & 46 and 47 & 48
Name	AUX IN 1 and AUX IN 2
Type	Configurable digital or 4-20mA inputs
Burners Affected	Configurable - Burner A only or Burner B only or both Burner A and Burner B

4.19.2 INTENDED FIELD DEVICE CONNECTIONS

Field Device	Configuration Requirements	Connection Diagrams
Appliance-wide digital input switch	Settings > Inputs > Aux 1/2 Type: Digital Mode: High/Low Trip Digital Trip Mode: As desired All other settings: Ignored	Digital Input – Dry Contact Digital Input – Wet Contact
Burner specific digital input switch	Settings > Inputs > Aux 1/2 Type: Digital Mode: Burner A or B High/Low Trip Digital Trip Mode: As desired All other settings: Ignored	Digital Input – Dry Contact Digital Input – Wet Contact
Appliance-wide 4-20mA input transmitter	Settings > Inputs > Aux 1/2 Type: 4-20 Mode: High/Low Trip Digital Trip Mode: Ignored 4-20 Span Min/Max: Transmitter Min/Max All other settings: As desired Settings > Setup > Units Aux In 1/2: As desired	Analog Input - Loop Powered 4-20mA Transmitter Analog Input – Self Powered 4-20mA Transmitter Analog Input – Input from PLC
Burner specific 4-20mA input transmitter	Settings > Inputs > Aux 1/2 Type: 4-20 Mode: Burner A or B High/Low Trip Digital Trip Mode: Ignored 4-20 Span Min/Max: Transmitter Min/Max All other settings: As desired Settings > Setup > Units Aux In 1/2: As desired	Analog Input - Loop Powered 4-20mA Transmitter Analog Input – Self Powered 4-20mA Transmitter Analog Input – Input from PLC
External Firing rate input from PLC	Settings > Inputs > Aux 1/2 Type: 4-20 4-20 Mode: Appliance Firing Rate All other settings: Ignored Settings > Proc Control > Configuration Process Control Mode: Firing Rate	Analog Input – Input from PLC
External Bath ¹ Setpoint adjustment input from PLC	Settings > Inputs > Aux 1/2 Type: 4-20 4-20 Mode: Bath ¹ Process SP Adjust 4-20 Span Min/Max: As desired All other settings: Ignored Settings > Temps > Bath¹ Mode: Process Control Settings > Setup > Units Aux In 1/2: Temperature	Analog Input – Input from PLC
Not Used	Settings > Inputs > Aux 1/2 Type: Disabled	N/A

¹ Aux Input can also be configured as a setpoint adjustment input for the Outlet or Aux Temp temperature inputs.

4.19.3 SYSTEM BEHAVIOR - DIGITAL INPUT SWITCH



Configuration Details		Scenario					
Mode	Digital Mode	Aux In Input	Burner State	Burner A Transition	Burner B Transition	Alerts Pane	
Any	Any	Energized	Any	No effect	No effect	N/A	
			Running state	Lockout	Lockout	Aux In Contact Open Alarm	
High Low Trip	Alarm	De-energized	Stopped state	Alarm	Alarm	Aux In Contact Open Alarm	
			Running state	Waiting	Waiting	Aux In Contact Open Wait	
	Wait	De-energized	Stopped state	No effect	No effect	Aux In Contact Open Wait	
			Any	No effect	No effect	Aux In Contact Open Warning	
	Main Permissive	De-energized	Main fuel state	Pilot	Pilot	Aux In Contact Open Main Permissive	
			Not a main fuel state	No effect	No effect	Aux In Contact Open Main Permissive	
	Burner A High Low Trip	Alarm	De-energized	Running state	Lockout	No effect	Aux In Contact Open A Alarm
				Stopped state	Alarm	No effect	Aux In Contact Open A Alarm
		Wait	De-energized	Running state	Waiting	No effect	Aux In Contact Open A Wait
				Stopped state	No effect	No effect	Aux In Contact Open A Wait
Warning		De-energized	Any	No effect	No effect	Aux In Contact Open A Warning	
Main Permissive		De-energized	Main fuel state	Pilot	No effect	Aux In Contact Open A Main Permissive	
			Not a main fuel state	No effect	No effect	Aux In Contact Open A Main Permissive	
Burner B High Low Trip		Alarm	De-energized	Running state	No effect	Lockout	Aux In Contact Open B Alarm
				Stopped state	No effect	Alarm	Aux In Contact Open B Alarm
		Wait	De-energized	Running state	No effect	Waiting	Aux In Contact Open B Wait
	Stopped state			No effect	No effect	Aux In Contact Open B Wait	
	Warning	De-energized	Any	No effect	No effect	Aux In Contact Open B Warning	
	Main Permissive	De-energized	Main fuel state	No effect	Pilot	Aux In Contact Open B Main Permissive	
			Not a main fuel state	No effect	No effect	Aux In Contact Open B Main Permissive	

4.19.4 SYSTEM BEHAVIOR – 4-20mA INPUT TRANSMITTER

Configuration Details		Scenario		Burner A Transition	Burner B Transition	Alerts Pane
Mode	4-20 Trip Mode ¹	Aux In Input	Burner State			
Any	Any	Valid Range	Any	No effect	No effect	N/A
		Out of Range	Running state	Lockout	Lockout	Aux In Out of Range Alarm
			Stopped state	Alarm	Alarm	Aux In Out of Range Alarm
		Alarm	Trip ¹	Running state	Lockout	Lockout
Stopped state	Alarm			Alarm	Aux In Trip ¹ Alarm	
High/Low Trip	Wait	Trip ¹	Running state	Waiting	Waiting	Aux In Trip ¹ Wait
			Stopped state	No effect	No effect	Aux In Trip ¹ Wait
	Warning	Trip ¹	Any	No effect	No effect	Aux In Trip ¹ Warning
			Main Permissive	Trip ¹	Main fuel state	Pilot
		Not a main fuel state	No effect	No effect	Aux In Trip ¹ Main Permissive	
		Alarm	Trip ¹	Running state	Lockout	No effect
Stopped state	Alarm			No effect	Burner A Aux In Trip ¹ Alarm	
Burner A High/Low Trip	Wait	Trip ¹	Running state	Waiting	No effect	Burner A Aux In Trip ¹ Wait
			Stopped state	No effect	No effect	Burner A Aux In Trip ¹ Wait
	Warning	Trip ¹	Any	No effect	No effect	Burner A Aux In Trip ¹ Warning
			Main Permissive	Trip ¹	Main fuel state	Pilot
		Not a main fuel state	No effect	No effect	Burner A Aux In Trip ¹ Main Permissive	
		Alarm	Trip ¹	Running state	No effect	Lockout
Stopped state	No effect			Alarm	Burner B Aux In Trip ¹ Alarm	
Burner B High/Low Trip	Wait	Trip ¹	Running state	No effect	Waiting	Burner B Aux In Trip ¹ Wait
			Stopped state	No effect	No effect	Burner B Aux In Trip ¹ Wait
	Warning	Trip ¹	Any	No effect	No effect	Burner B Aux In Trip ¹ Warning
			Main Permissive	Trip ¹	Main fuel state	No effect
		Not a main fuel state	No effect	No effect	Burner B Aux In Trip ¹ Main Permissive	
		Appliance Firing Rate	Ignored	Refer to Temperature Control Valve output sections for TCV behavior with an external firing rate signal.		

¹ The above table applies to both high trip and low trip events. Each Trip mode setting can be configured independently, and the Alerts Pane will annunciate the specific event that has occurred.

Feature Note
Process Setpoint Adjustment Input

-  Settings
-  Inputs
-  Aux In 1/Aux In 2

Configuring the Aux Input **Mode** setting as **Process SP Adjust** allows a process setpoint to be updated remotely from an external 4-20mA signal. This can be used for applications that require seasonal setpoint adjustments or other process temperature compensation. The Process Setpoint Adjust input can change the configured **Process Setpoint** of a desired temperature input between its configured **Low Temp Setpoint** and **Main Off Setpoint**. A 4mA input signal corresponds to the configured **Aux In 4-20 Span Min** setting and a 20mA input signal corresponds to the configured **Aux In 4-20 Span Max** setting. The Process Setpoint will be clamped between the configured **Low Temp Setpoint** and **Main Off Setpoint** regardless of the setpoint adjustment input signal (e.g. All setpoint adjustment signals below the configured **Low Temp Setpoint** will change the **Process Setpoint** to match the **Low Temp Setpoint**.)

4.20 BURNER B PROOF OF CLOSURE INPUT

4.20.1 DETAILS

Item	
Terminals	49 & 50
Name	POC B
Type	Digital input
Burners Affected	Burner B only

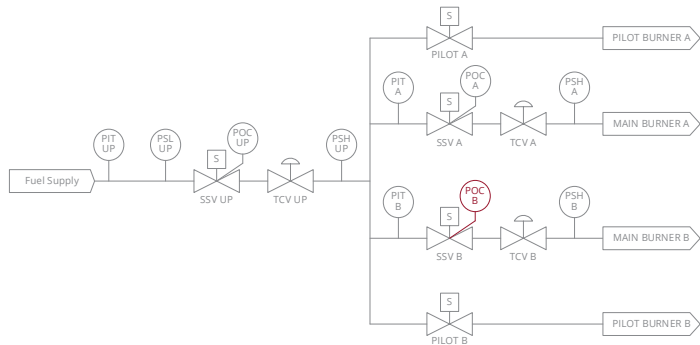

4.20.2 INTENDED FIELD DEVICE CONNECTIONS

Field Device	Configuration Requirements	Connection Diagrams
Burner B Main Valve (SSV B) Proof of Closure Switch	Settings > Inputs > Proof of Closure Proof of Closure B: Enabled	Digital Input – Dry Contact Digital Input – Wet Contact
Not Used	Settings > Inputs > Proof of Closure Proof of Closure B: Disabled	N/A

4.20.3 SYSTEM BEHAVIOR

POC B Setting	Scenario		Burner A Transition	Burner B Transition	Alerts Pane
	POC. B Input	Burner State			
Enabled	Energized	Main fuel state	No effect	No effect	Proof of Closure B Failed to Open Warning
		Not a main fuel state	No effect	No effect	N/A
	De-energized	Main fuel state	No effect	No effect	N/A
		Running - not a main fuel state	No effect	Lockout	Proof of Closure Contact B Open Alarm
Disabled	Any	Stopped	No effect	Alarm	Proof of Closure Contact B Open Alarm
		Any	No effect	No effect	N/A

4.21 UPSTREAM PROOF OF CLOSURE INPUT

4.21.1 DETAILS

Item	
Terminals	51
Name	POC UP
Type	Digital input
Burners Affected	Burner A and Burner B

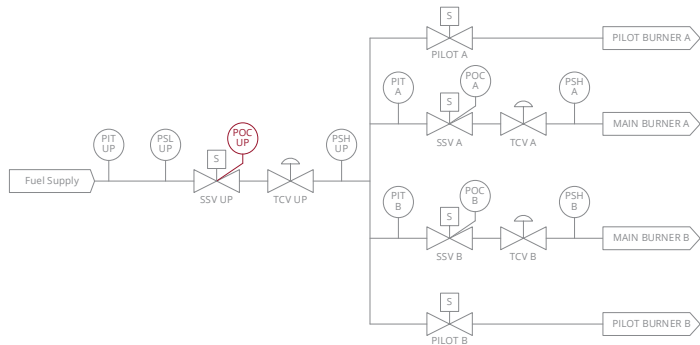

4.21.2 INTENDED FIELD DEVICE CONNECTIONS

Field Device	Configuration Requirements	Connection Diagrams
Upstream Main Valve (SSV UP) Proof of Closure Switch	Settings > Inputs > Proof of Closure Proof of Closure Upstream: Enabled	Upstream Proof of Closure Wiring
Not Used	Settings > Inputs > Proof of Closure Proof of Closure Upstream: Disabled	N/A

4.21.3 SYSTEM BEHAVIOR

POC Up Setting	Scenario		Burner A Transition	Burner B Transition	Alerts Pane
	POC Up Input	Burner State			
Enabled	Energized	Any burner in a main fuel state	No effect	No effect	Upstream Proof of Closure Failed to Open Warning
		Neither burner in a main fuel state	No effect	No effect	N/A
	De-energized	Any burner in a main fuel state	No effect	No effect	N/A
		Running - neither burner in a main fuel state	Lockout	Lockout	Upstream Proof of Closure Contact Open Alarm
Disabled	Any	Stopped	Alarm	Alarm	Upstream Proof of Closure Contact Open Alarm
		Any	No effect	No effect	N/A

4.22 PILOT IGNITION I/O

4.22.1 DETAILS

Item	
Terminals	53, 54, 55, 56 and 57, 58, 59, 60
Name	PILOT 1 ION/COIL and PILOT 2 ION/COIL
Type	ION – Ionization flame detection signal utilizing flame rectification COIL – Powered ignition output

4.22.2 INTENDED FIELD DEVICE CONNECTIONS

Field Device	Configuration Requirements	Connection Diagrams
Ignition Coil	Settings > Proc Control > Ignition Mode: Coil	Single Rod Ignition Wiring Dual Rod Ignition Wiring
Separate ignition module with DC input	Settings > Proc Control > Ignition Mode: HEI	Dual Rod Ignition Wiring

4.22.3 SYSTEM BEHAVIOR – COIL OUTPUTS

Configuration Details	Burner State	Associated Coil Output Behavior
Mode: Coil	Ignition	Energized - Pulsed
	Any other state	De-energized
Mode: HEI	Ignition	Energized - Steady
	Any other state	De-energized

4.22.4 SYSTEM BEHAVIOR – IONIZATION INPUTS

Flame Voltage Readings	System Interpretation	
Strength	Greater than 800 mV	Strong Flame Detected
	Between 400 mV and 800 mV	Weak Flame Detected
	Less than 400 mV	No Flame Detected
DC High	Above 2500 mV	Flame Voltage is within acceptable range
	Below 2500 mV	Flame Voltage Fault
AC	Above 500 mV _{pk-pk}	Flame Load Monitor Check passed
	Below 500 mV _{pk-pk}	Flame Load Monitor Check failed

Check the Flame Diagnostics Screen (System > Diagnostics > Flame) to see real-time flame strength and voltage readings.

4.23 EXTERNAL IGNITION SWITCH INPUT

4.23.1 DETAILS

Item	
Terminals	PWR, IGN, RUN
Name	SWITCH
Type	Digital input
Burners Affected	Burner A and Burner B

4.23.2 INTENDED FIELD DEVICE CONNECTIONS

Field Device	Configuration Requirements	Connection Instructions
Profire PF2200 Ignition Switch	N/A – Always enabled	Connect factory wired switch connector to BMS Switch terminal header.
Not Used	N/A – Always enabled	Add wire jumper between Switch PWR and RUN terminals

4.23.3 SYSTEM BEHAVIOR

External Switch Position	Initial System State		Burner A Transition	Burner B Transition	Alerts Pane / Lockout Screen
	Burner A	Burner B			
Run	Any	Any	No effect	No effect	N/A
Ignite for less than 1s	Any	Any	No effect	No effect	N/A
Ignite for more than 1s	Ready	Ready	Startup	Startup	N/A
Ignite for more than 1s	Ready	Not Ready	Startup	No effect	N/A
Ignite for more than 1s	Not Ready	Ready	No effect	Startup	N/A
Ignite for more than 5s	Stopped state	Stopped state	Alarm	Alarm	External Switch Stuck Alarm
	Running state	Stopped state	Lockout	Alarm	External Switch Stuck Alarm
Stop	Running state	Running state	Lockout	Lockout	External Switch Stuck Alarm
	Stopped state	Stopped state	Alarm	Alarm	User Stop via External Switch Alarm
	Running state	Stopped state	Lockout	Alarm	User Stop via External Switch Alarm
Run to Stop to Run	Running state	Running state	Lockout	Lockout	User Stop via External Switch Alarm
	Lockout	Lockout	Ready	Ready	N/A
	Lockout	Stopped state	Ready	No effect	N/A
	Lockout	Running state	No effect	Lockout	Burner A: Original Lockout message Burner B: Stopped via External Switch

toggling the External Ignition Switch from Run position to Stop position to Run position within 30 seconds will acknowledge on-screen lockout messages and transition locked out burners out of the Lockout state.

4.24 BATH TEMPERATURE INPUT

4.24.1 DETAILS

Item	
Terminals	61, 62, 63 and 64, 65, 66
Name	BATH
Type	Configurable Type K Thermocouple or PT-100 RTD temperature input
Burners Affected	Burner A and Burner B

4.24.2 INTENDED FIELD DEVICE CONNECTIONS

Field Device	Configuration Requirements	Connection Diagrams
Type K Thermocouple installed in Appliance Bath (Grounded or Ungrounded)	<p>Settings > Temps > Bath Type: TC Input: As desired ¹ All other settings: As desired</p> <p>Settings > Proc Control > Configuration Process Control Mode: As desired Pilot Off Mode: As desired</p> <p>Settings > Setup > Units Temperature: As desired</p> <p>System > Customization > Status Priority As desired</p>	<p>Temperature Input- Dual Type K Thermocouple Temperature Input- Single Type K Thermocouple</p>
PT100 RTD installed in Appliance Bath	<p>Settings > Temps > Bath Type: RTD Input: As desired ¹ All other settings: As desired</p> <p>Settings > Proc Control > Configuration Process Control Mode: As desired Pilot Off Mode: As desired</p> <p>Settings > Setup > Units Temperature: As desired</p> <p>System > Customization > Status Priority As desired</p>	<p>Temperature Input- Dual 3-Wire RTD Temperature Input- Single 3-wire RTD</p>

¹ Bath **Input** setting is required to be set to **Dual** if the Bath Input is specified as a safety function.

4.24.3 SYSTEM BEHAVIOR

Temperature Reading	Input Mode	Initial Burner State	Burner A Transition	Burner B Transition	Alerts Pane/Lockout Screen
Open/Out of Range	Any	Running state	Lockout	Lockout	Bath Out of Range
		Stopped state	Alarm	Alarm	Bath Out of Range Alarm
Short in RTD Mode	Any	Running state	Lockout	Lockout	Bath Sensor Short
		Stopped state	Alarm	Alarm	Bath Sensor Short Alarm
Above High Temp Setpoint	Any	Running state	Lockout	Lockout	Bath High Temp ESD
		Stopped state	Alarm	Alarm	Bath High Temp ESD Alarm
Below High Temp Setpoint and Above Low Temp Setpoint	Process Control	Refer to Operating Sequence Section for state specific behavior			
	High Temp ESD	Any	No effect	No effect	N/A

4.25 OUTLET/BURNER B STACK TEMPERATURE INPUT

4.25.1 DETAILS

Item	
Terminals	67, 68, 69
Name	OUTLET
Type	Configurable Type K Thermocouple or PT-100 RTD temperature input
Burners	Outlet: Burner A and Burner B
Affected	Stack B: Burner B only

4.25.2 INTENDED FIELD DEVICE CONNECTIONS

Field Device	Configuration Requirements	Connection Diagrams
Single Element Type K Thermocouple installed at Appliance Outlet (Grounded or Ungrounded)	Settings > Temps > Outlet Type: TC Mode: Outlet - As desired Settings > Setup > Units Temperature: As desired System > Customization > Status Priority As desired	Temperature Input- Single Type K Thermocouple
Single Element PT100 RTD installed at Appliance Outlet	Settings > Temps > Outlet Type: RTD Mode: Outlet - As desired Settings > Setup > Units Temperature: As desired System > Customization > Status Priority As desired	Temperature Input- Single 3-wire RTD
Single Element Type K Thermocouple installed in Burner B Stack (Grounded or Ungrounded)	Settings > Temps > Outlet Type: TC Mode: Stack B - As desired Settings > Setup > Units Temperature: As desired System > Customization > Status Priority As desired	Temperature Input- Single Type K Thermocouple
Single Element PT100 RTD installed in Burner B Stack	Settings > Temps > Outlet Type: RTD Mode: Stack B - As desired Settings > Setup > Units Temperature: As desired System > Customization > Status Priority As desired	Temperature Input- Single 3-wire RTD
Not Used	Settings > Temps > Outlet Mode: Disabled	N/A

4.25.3 SYSTEM BEHAVIOR - OUTLET

Temperature Reading	Input Mode	Initial Burner State	Burner A Transition	Burner B Transition	Alerts Pane/Lockout Screen
Any	Disabled or Display Only	Any	No effect	No effect	N/A
Open/Out of Range	Not Disabled or Display Only	Running state	Lockout	Lockout	Outlet Open/Out of Range Alarm
		Stopped state	Alarm	Alarm	Outlet Open/Out of Range Alarm
Short in RTD Mode	Not Disabled or Display Only	Running state	Lockout	Lockout	Outlet Sensor Short Alarm
		Stopped state	Alarm	Alarm	Outlet Sensor Short Alarm
Above High Temp Setpoint	Not Disabled or Display Only	Running state	Lockout	Lockout	Outlet High Temp ESD Alarm
		Stopped state	Alarm	Alarm	Outlet High Temp ESD Alarm
Below High Temp Setpoint and Above Low Temp Setpoint	Not Process Control	Any	No effect	No effect	N/A
	Process Control	Refer to Operating Sequence Section for state specific behavior			

4.25.4 SYSTEM BEHAVIOR – STACK B

Temperature Reading	Input Mode	Initial Burner State	Burner A Transition	Burner B Transition	Alerts Pane/Lockout Screen
Any	Disabled or Display Only	Any	No effect	No effect	N/A
Open/Out of Range	High Temp ESD	Running state	Lockout	Lockout	Stack B Open/Out of Range Alarm
		Stopped state	Alarm	Alarm	Stack B Open/Out of Range Alarm
Short in RTD Mode	High Temp ESD	Running state	Lockout	Lockout	Stack B Sensor Short Alarm
		Stopped state	Alarm	Alarm	Stack B Sensor Short Alarm
Above High Temp Setpoint	High Temp ESD	Running state	No effect	Lockout	Stack B High Temp ESD Alarm
		Stopped state	No effect	Alarm	Stack B High Temp ESD Alarm
Below High Temp Setpoint	High Temp ESD	Any	No effect	No effect	N/A

4.26 SHARED STACK/BURNER A STACK TEMPERATURE INPUT

4.26.1 DETAILS

Item	
Terminals	70, 71, 72
Name	STACK
Type	Configurable Type K Thermocouple or PT-100 RTD temperature input
Burners	Stack: Burner A and Burner B
Affected	Stack A: Burner A only

4.26.2 INTENDED FIELD DEVICE CONNECTIONS

Field Device	Configuration Requirements	Connection Diagrams
Single Element Type K Thermocouple installed in shared appliance Stack (Grounded or Ungrounded)	Settings > Temps > Stack Type: TC Mode: As desired Settings > Setup > Units Temperature: As desired System > Customization > Status Priority As desired	Temperature Input- Single Type K Thermocouple
Single Element Type K Thermocouple installed in Burner A Stack (Grounded or Ungrounded)	All settings as above Settings > Temps > Outlet Mode: Stack B - As desired	Temperature Input- Single Type K Thermocouple
Single Element PT100 RTD installed in shared appliance Stack	Settings > Temps > Stack Type: RTD Mode: As desired Settings > Setup > Units Temperature: As desired System > Customization > Status Priority As desired	Temperature Input- Single 3-wire RTD
Single Element PT100 RTD installed in Burner A Stack	All settings as above Settings > Temps > Outlet Mode: Stack B - As desired	Temperature Input- Single 3-wire RTD
Not Used	Settings > Temps > Stack Mode: Disabled	N/A

4.26.3 SYSTEM BEHAVIOR – SHARED APPLIANCE STACK

Temperature Reading	Input Mode	Initial Burner State	Burner A Transition	Burner B Transition	Alerts Pane/Lockout Screen
Any	Disabled or Display Only	Any	No effect	No effect	N/A
Open/Out of Range	High Temp ESD	Running state	Lockout	Lockout	Stack Open/Out of Range Alarm
		Stopped state	Alarm	Alarm	Stack Open/Out of Range Alarm
Short in RTD Mode	High Temp ESD	Running state	Lockout	Lockout	Stack Sensor Short Alarm
		Stopped state	Alarm	Alarm	Stack Sensor Short Alarm
Above High Temp Setpoint	High Temp ESD	Running state	Lockout	Lockout	Stack High Temp ESD Alarm
		Stopped state	Alarm	Alarm	Stack High Temp ESD Alarm
Below High Temp Setpoint	High Temp ESD	Any	No effect	No effect	N/A

4.26.4 SYSTEM BEHAVIOR – STACK A

Temperature Reading	Input Mode	Initial Burner State	Burner A Transition	Burner B Transition	Alerts Pane/Lockout Screen
Any	Disabled or Display Only	Any	No effect	No effect	N/A
Open/Out of Range	High Temp ESD	Running state	Lockout	Lockout	Stack A Open/Out of Range Alarm
		Stopped state	Alarm	Alarm	Stack A Open/Out of Range Alarm
Short in RTD Mode	High Temp ESD	Running state	Lockout	Lockout	Stack A Sensor Short Alarm
		Stopped state	Alarm	Alarm	Stack A Sensor Short Alarm
Above High Temp Setpoint	High Temp ESD	Running state	Lockout	No effect	Stack A High Temp ESD Alarm
		Stopped state	Alarm	No effect	Stack A High Temp ESD Alarm
Below High Temp Setpoint	High Temp ESD	Any	No effect	No effect	N/A

5 OPERATING SEQUENCE

The PF2200-DB utilizes a state-based control scheme to safely monitor and control each burner individually. Each burner state has specific entry and exit requirements and defined output behavior. The sections below outline the transitions, output behavior and configuration settings related to each burner state.

Each burner operates independently in accordance with the operating sequence detailed below. The current state of each burner is always displayed in the Status Bar located at the top of the User Interface screen.

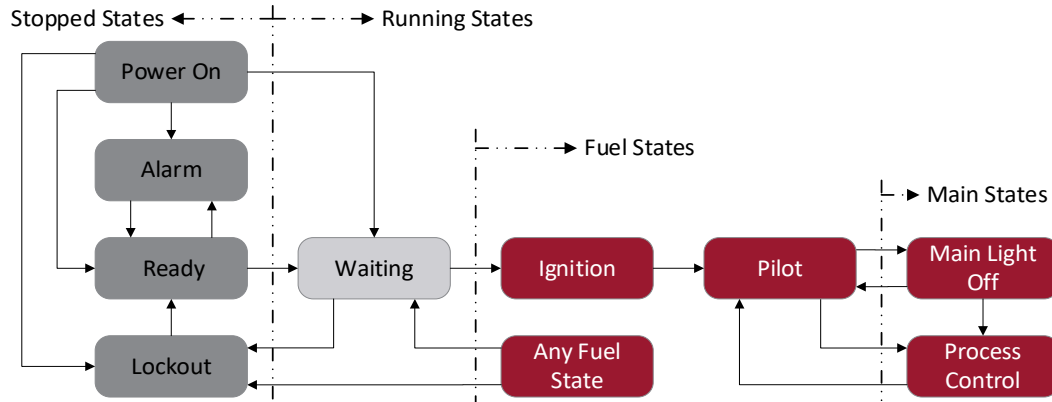

State Name	Stopped State	Running State	Fuel State	Main State	Coil Output	Pilot Output	SSV Output
Power On	Yes	No	No	No	De-energized	De-energized	De-energized
Alarm	Yes	No	No	No	De-energized	De-energized	De-energized
Ready	Yes	No	No	No	De-energized	De-energized	De-energized
Lockout	Yes	No	No	No	De-energized	De-energized	De-energized
Waiting	No	Yes	No	No	De-energized	De-energized	De-energized
Ignition	No	Yes	Yes	No	Energized	Energized	De-energized
Pilot	No	Yes	Yes	No	De-energized	Energized	De-energized
Main Light Off – Requesting Light Off	No	Yes	Yes	Yes	De-energized	Energized	De-energized
Main Light Off – Main Delay	No	Yes	Yes	Yes	De-energized	Energized	Energized
Process Control	No	Yes	Yes	Yes	De-energized	Energized	Energized

Alert types displayed in the Alerts Pane on the Status Screen:



1. **Alarm** – Prevents the burner from entering any running state.
2. **Wait** – Prevents the burner from entering any fuel state.
3. **Main Permissive** – Prevents the burner from entering any main fuel state.
4. **Warning** – Displayed on screen only - does not affect burner state.

Feature Note Valve Synchronization

When the **Valve Sync** setting is **Enabled**, the burners will not operate with differing valve output states. The system will coordinate state transitions per the following rules:

1. If any burner is stopped, the other burner cannot be in a running state.
2. If any burner is in the Waiting state, the other burner cannot be in a fuel state.
3. If any burner is in the Pilot state, the other burner cannot be in a main fuel state.

Additional configuration requirements:
Minimum Burners Running must be set to **2**

-  Settings
-  Proc Control
-  Configuration

5.1 POWER ON STATE

The Power On state is the default state of the burner upon initial powered up. All safety outputs are de-energized and a purge event is triggered upon entering the state.

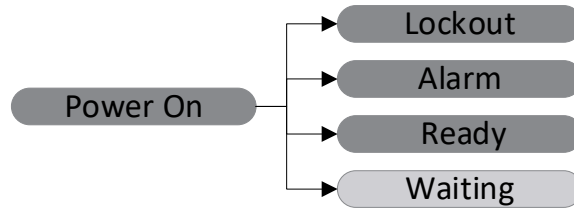

5.1.1 POWERED OUTPUT BEHAVIOR IN THE POWER ON STATE

Output	Behavior
Coil Output	De-energized
Pilot Valve Output	De-energized
Main SSV Output	De-energized

5.1.2 TRANSITIONS TO THE POWER ON STATE

From	Scenario	Condition
Power Off	System has just powered up	Any

5.1.3 TRANSITIONS FROM THE POWER ON STATE

To	Scenario	Condition
Lockout	Any	Unacknowledged lockout message present at last power down
Alarm	Any	Alarm condition present
Ready	Burner was not running at last power down	Voltage Restart setting Enabled , AND No alarm condition present
	Any	Voltage Restart setting Disabled , AND No alarm condition present
Waiting	Burner was running at last power down	Voltage Restart setting Enabled , AND No alarm condition present

The **Voltage Restart** setting dictates whether a running burner will be automatically restarted following a power loss event. The burner can only restart if (1) there are no alarms present, or (2) all present alarms pertain to the other burner only.

5.1.4 RELATED SETTINGS – POWER ON STATE

Setting	Navigation
Voltage Restart	Settings > Setup > Commissioning
Purge Time	Settings < Proc Control > Timing

5.2 LOCKOUT STATE

The Lockout state holds all safety outputs in the de-energized position, triggers a purge and prevents the locked out burner from entering any other state until the user acknowledges an on-screen lockout message.

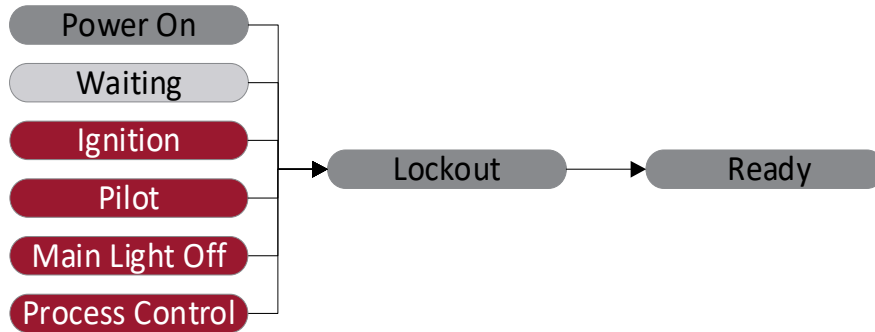

5.2.1 POWERED OUTPUT BEHAVIOR IN THE LOCKOUT STATE

Output	Behavior
Coil Output	De-energized
Pilot Valve Output	De-energized
Main SSV Output	De-energized

5.2.2 TRANSITIONS TO THE LOCKOUT STATE

From	Scenario	Condition
Power On	System has just powered up	Associated burner lockout message present at last power down
Waiting	Any	Associated burner or shared appliance alarm condition present
Ignition	Burner stopped by user	Any
	Any	Associated burner or shared appliance alarm condition present
	Burner stopped by user Pilot fails to ignite	Any Ignition attempt limit has been exceeded
Pilot	Any	Associated burner or shared appliance alarm condition present
Main Light Off	Burner stopped by user	Any
Process Control	Burner stopped by user	Any
	Flame failure	Relight Attempts limit has been exceeded

There are 4 ways to stop the burner(s):

1. USER INTERFACE: Press **STOP** then select which burner to stop and press **OK**.

Note: Pressing **STOP** twice will stop both burners

2. EXTERNAL IGNITION SWITCH: Turn switch to STOP position to stop both burners.
3. ESD INPUT: Toggle input to de-energized position to stop both burners
4. MODBUS: Write Stop command to the Appliance or burner specific Start/Stop Modbus register. Refer to the Dual Burner Modbus Configuration Guide for Modbus register addresses and commands.

5.2.3 TRANSITIONS FROM THE LOCKOUT STATE

To	Scenario	Condition
Ready	Lockout message acknowledged by user	Any

There are 4 ways to acknowledge a Lockout:

1. USER INTERFACE: Press  on the keypad.
2. EXTERNAL IGNITION SWITCH: Toggle switch from RUN to STOP to RUN position. Note: If one burner is still running, this action will cause it to transition to the Lockout state.
3. REMOTE START INPUT (If enabled): Toggle input from energized to de-energized to energized. Note that this action will start any burner that is in the Ready state and will transition any running burner to the Waiting state.
4. MODBUS: Write Acknowledge command to the Clear Shutdown Code Modbus register. Refer to the Dual Burner Modbus Configuration Guide for Modbus register addresses and commands.

5.2.4 RELATED SETTINGS - LOCKOUT STATE

Setting	Navigation
Relight Attempts	Settings > Proc Control > Ignition
Purge Time	Settings > Proc Control > Timing
Remote Start	Settings > Inputs > Remote Start
RTU Communication	Settings > Setup > Modbus

5.3 ALARM STATE

The Alarm state is the state to which the burner transitions when an alarm is present and the burner is not running. A burner cannot transition out of the Alarm state until all associated burner specific and shared appliance alarms are cleared. Check the Alerts Pane on the screen to see a list of active alarms.



5.3.1 POWERED OUTPUT BEHAVIOR IN THE ALARM STATE

Output	Behavior
Coil Output	De-energized
Pilot Valve Output	De-energized
Main SSV Output	De-energized

5.3.2 TRANSITIONS TO THE ALARM STATE

From	Scenario	Condition
Power On	System has just powered up	Associated burner or shared appliance alarm condition present
Ready	Any	Associated burner or shared appliance alarm condition present

5.3.3 TRANSITIONS FROM THE ALARM STATE

To	Scenario	Condition
Ready	Any	No associated burner or shared appliance alarm conditions present

The UI Alerts Pane only displays active alerts – once an alarm condition is cleared, the corresponding alarm is removed from the Alerts Pane. Check the Event Log (System Screen > Logging > Events) for a history of all alarm events.

5.4 READY STATE

The Ready state is the state to which the burner transitions when all associated burner and appliance alarm conditions are cleared and the burner is safe to start. A burner can only be started from the Ready state.

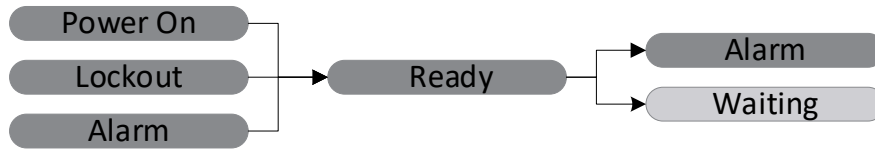

5.4.1 POWERED OUTPUT BEHAVIOR IN THE READY STATE

Output	Behavior
Coil Output	De-energized
Pilot Valve Output	De-energized
Main SSV Output	De-energized

5.4.2 TRANSITIONS TO THE READY STATE

From	Scenario	Condition
Power On	System has just powered up	No associated burner or shared appliance alarm conditions present
Lockout	Lockout message acknowledged by user	Any
Alarm	Any	No associated burner or shared appliance alarm conditions present

5.4.3 TRANSITIONS FROM THE READY STATE

To	Scenario	Condition
Alarm	Any	Associated burner or shared appliance alarm condition present
Waiting	Burner started by user	Any

There are 4 ways to start a burner from the Ready state:

1. USER INTERFACE: Press **START**, confirm which burner(s) to start and press **OK**.
2. EXTERNAL IGNITION SWITCH: Turn switch to the Ignite position and hold for 1 second. Note that this action will start any burner that is in the Ready state.
3. REMOTE START INPUT (if enabled): Toggle input from energized to de-energized to energized when no lockout messages are present on the screen. Note that this action will start any burner that is in the Ready state and will transition any running burner to the Waiting state.
4. MODBUS: Write Start command to the Appliance or burner specific Start/Stop Modbus register. Refer to the Modbus Register Document for register addresses and commands.

5.4.4 RELATED SETTINGS – READY STATE

Setting	Navigation
Remote Start	Settings > Inputs > Remote Start
RTU Communication	Settings > Setup > Modbus

5.5 WAITING STATE

The Waiting state is a running state that does not admit fuel to the burner. The system will initiate a purge on a burner entering the Waiting state from a fuel state. The burner will proceed to the Ignition state when all associated burner and appliance wait conditions are cleared.

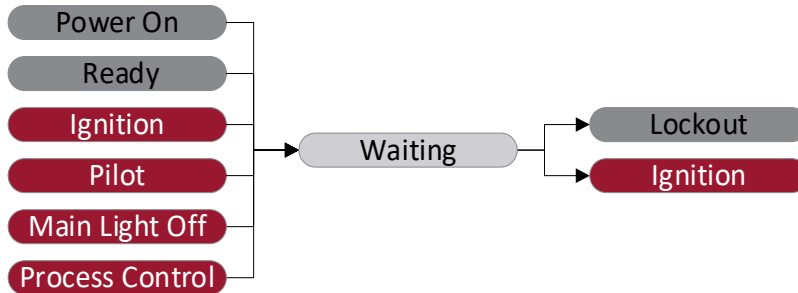

5.5.1 POWERED OUTPUT BEHAVIOR IN THE WAITING STATE

Output	Behavior
Coil Output	De-energized
Pilot Valve Output	De-energized
Main SSV Output	De-energized

5.5.2 TRANSITIONS TO THE WAITING STATE

From	Scenario	Condition
Power On	Burner was running at last power down	Voltage Restart setting Enabled , AND No associated burner or shared appliance alarm conditions present
Ready	Burner started by user	Any
Ignition	Any	Associated burner or shared appliance wait condition present
	Pilot fails to ignite	Ignition attempt limit not yet exceeded
Pilot	Flame failure	Relight attempts limit not yet exceeded
	Any	Associated burner or shared appliance wait condition present
	Process Temperature is too high	Pilot Off Mode is set to Off at Pilot Off Setpoint
Main Light Off	Flame failure	Relight attempts limit not yet exceeded
Process Control	Any	Associated burner or shared appliance wait condition present
	Process Temperature is too high	Pilot Off Mode is set to Off at Main Off Setpoint

5.5.3 TRANSITIONS FROM THE WAITING STATE

To	Scenario	Condition
Lockout	Any	Associated burner or shared appliance alarm condition present
	Burner set to transition to Ignition state	Flame is detected
	Burner stopped by user	Any
Ignition	Any	All associated burner or shared appliance wait conditions have been cleared

5.5.4 RELATED SETTINGS – WAITING STATE

Setting	Navigation
Voltage Restart	Settings > Setup > Commissioning
Relight Attempts	Settings > Proc Control > Ignition
Purge Time	Settings > Proc Control > Timing

5.6 IGNITION STATE

The Ignition state is the first fuel state in the burner startup sequence. The coil output of the igniting burner is energized, then its pilot valve output is energized to attempt to light off the pilot burner for up to 10 seconds. Successful pilot ignition is required before the burner can transition into any other fuel state.



5.6.1 POWERED OUTPUT BEHAVIOR IN THE IGNITION STATE

Output	Behavior
Coil Output	Energized
Pilot Valve Output	Energized
Main SSV Output	De-energized

5.6.2 TRANSITIONS TO THE IGNITION STATE

From	Scenario	Condition
Waiting	Any	All associated burner or shared appliance wait conditions have been cleared

5.6.3 TRANSITIONS FROM THE IGNITION STATE

To	Scenario	Condition
Lockout & purge	Any	Associated burner or shared appliance alarm condition present
	Burner stopped by user	Any
	Pilot fails to ignite following user start	Ignition has failed 3 consecutive attempts
	Pilot fails to ignite following a flame loss in another fuel state	Ignition attempts exceed Relight Attempts setting
Waiting & purge	Flame detected	Pilot valve output has not yet been energized
	Any	Wait condition is present
Pilot	Pilot fails to ignite	Ignition attempt limit not yet exceeded
	Pilot ignition successful	Any

The **Relight Attempts** setting dictates only the number of relight attempts allowed following a flame-loss event. The system can attempt pilot ignition 3 times upon a fresh user start, regardless of the setting value.

5.6.4 RELATED SETTINGS – IGNITION STATE

Setting	Navigation
Relight Attempts	Settings > Proc Control > Ignition
Ignition Mode	Settings > Proc Control > Ignition

5.7 PILOT STATE

The Pilot state ensures that a reliable pilot flame is established prior to lighting off the main burner. A burner can remain in the pilot state when heat demand is low and will transition to a main state when the heat demand increases.



5.7.1 POWERED OUTPUT BEHAVIOR IN THE PILOT STATE

Output	Behavior
Coil Output	De-energized
Pilot Valve Output	Energized
Main SSV Output	De-energized

5.7.2 TRANSITIONS TO THE PILOT STATE

From	Scenario	Condition
Ignition	Pilot ignition successful	Any
Main Light Off	Process Temperature is too high	Pilot Off Mode is set to Off at Pilot Off Setpoint
Process Control	Any	Associated burner or shared appliance main permissive condition present

5.7.3 TRANSITIONS FROM THE PILOT STATE

To	Scenario	Condition
Lockout & purge	Any	Associated burner or shared appliance alarm condition present
	Burner stopped by user	Any
	Flame failure	Relight attempts limit has been exceeded
Waiting & purge	Any	Wait condition present
	Flame failure	Relight attempts limit not yet exceeded
	Process temperature exceeds Pilot Off Setpoint	Pilot Off Mode is set to Off at Pilot Off Setpoint
Main Light Off	Process temperature exceeds Main Off Setpoint	Pilot Off Mode is set to Off at Main Off Setpoint
	Process Temperature is too low	No associated burner or shared appliance main permissive conditions present, and Process Control Mode is not set to On/Off Control
Process Control	Process Temperature is too low	No associated burner or shared appliance main permissive conditions present, and Process Control Mode is set to On/Off Control

5.7.4 RELATED SETTINGS – PILOT STATE

Setting	Navigation
Relight Attempts	Settings > Proc Control > Ignition
Pilot Startup Delay Time	Settings > Proc Control > Timing
Pilot Off Mode	Settings > Proc Control > Configuration

5.8 MAIN LIGHT OFF STATE

The Main Light Off state allows for the controlled light off of the main burners before admitting maximum fuel. Upon entry into the Main Light off State, the burner holds the Main SSV outputs de-energized for the duration of the configured **Request Light Off Delay Time** to allow the TCV to reach its configured **Minimum Position** prior to lighting off the main burner. The Main SSV outputs are then energized and the system continues to hold the TCV at its **Minimum Position** for the duration of the configured **Main Startup Delay Time** to allow the burner to heat up gradually before transitioning into a Process Control state.



5.8.1 POWERED OUTPUT BEHAVIOR IN THE MAIN LIGHT OFF STATE

Output	Requesting Light Off	Main Delay
Coil Output	De-energized	De-energized
Pilot Valve Output	Energized	Energized
Main SSV Output	De-energized	Energized

5.8.2 TRANSITIONS TO THE MAIN LIGHT OFF STATE

From	Scenario	Condition
Pilot	Process Temperature is too low	No associated burner or shared appliance main permissive condition present, and Process Control Mode is not set to On/Off Control

The **Main Startup Delay Time** is only enforced when lighting off the main burner following a user start. If the burner is re-entering the Main Light Off state after having previously been running in Process Control, the **Main Startup Delay Time** is ignored and the burner proceeds directly to the Process control state after the **Request Light Off Delay Time** has elapsed and the main SSV output has been energized.

5.8.3 TRANSITIONS FROM THE MAIN LIGHT OFF STATE

To	Scenario	Condition
Lockout & purge	Any	Associated burner or shared appliance alarm condition present
	Burner stopped by user	Any
	Flame failure	Relight Attempts limit has been exceeded
Waiting & purge	Any	Associated burner or shared appliance wait condition present
	Flame failure	Relight attempts limit not yet exceeded
	Process Temperature is too high	Pilot Off Mode is set to Off at Main Off Setpoint
Pilot	Process Temperature is too high	Pilot Off Mode is set to Off at Pilot Off Setpoint
	Main Permissive condition is present	Any
Process Control	Main Startup Delay Time has elapsed	Any

5.8.4 RELATED SETTINGS – MAIN LIGHT OFF STATE

Setting	Navigation
Relight Attempts	Settings > Proc Control > Ignition
Request Light Off Delay Time	Settings > Proc Control > Timing
Main Startup Delay Time	Settings > Proc Control > Timing
Pilot Off Mode	Settings > Proc Control > Configuration

5.9 PROCESS CONTROL STATES

The Process Control states are the states to which the burner transitions when its heat demand is the highest. The system attempts to maintain the process temperature at the user configured Process Setpoint in accordance with the user selected **Process Control Mode**. The Process Control states are:

1. Main – Used when system is configured for On/Off Control.
2. PID Control – Used when system is configured for PID Control or External Firing Rate control.



5.9.1 POWERED OUTPUT BEHAVIOR IN THE PROCESS CONTROL STATES

Output	Behavior
Coil Output	De-energized
Pilot Valve Output	Energized
Main SSV Output	Energized

5.9.2 TRANSITIONS TO THE MAIN STATE

From	Scenario	Condition
Pilot	Process Temperature is too low	No associated burner or shared appliance main permissive conditions present, and Process Control Mode is set to On/Off Control

5.9.3 TRANSITIONS TO THE PID CONTROL STATE

From	Scenario	Condition
Main Light Off	Main Startup Delay has elapsed	Any

5.9.4 TRANSITIONS FROM THE PROCESS CONTROL STATES

To	Scenario	Condition
Lockout & purge	Any	Associated burner or shared appliance alarm condition present
	Burner stopped by user	Any
	Flame failure	Relight Attempts limit has been exceeded
Waiting & purge	Flame failure	Relight attempts limit not yet exceeded
	Any	Associated burner or shared appliance wait condition is present
Pilot	Process Temperature is too high	Pilot Off Mode is set to Off at Main Off Setpoint
	Any	Associated burner or shared appliance main permissive condition is present
	Process Temperature is too high	Pilot Off Mode is set to Off at Pilot Off Setpoint

5.9.5 RELATED SETTINGS – PROCESS CONTROL STATES

Setting	Navigation
Relight Attempts	Settings > Proc Control > Ignition
Process Control Mode	Settings > Proc Control > Configuration
Pilot Off Mode	Settings > Proc Control > Configuration
PID Parameters	Settings > Proc Control > PID Control
Aux Firing Rate Settings	Setting > Inputs > Aux 1 or Aux 2
Process temperature setpoints	Setting > Temperatures

6 INSTALLATION



Warning: Installation and modification shall not be performed while the system is energized. Disconnect power source prior to connecting devices or modifying wiring.

Installers and commissioners of the PF2200-DB system must:

- Understand local codes and how they apply to the installation (for both electrical and mechanical aspects of the installation).
- Understand the electrical and mechanical limitations of the product and how that relates to the installation.
- Understand the safety and operational effects of modifying system settings or wiring.
- Verify all required safety functions prior to completing the commissioning of the appliance.
- Be fluent in the English language (the only language this product supports).
- Be familiar with navigating the product menus and modifying settings.

6.1 MOUNTING CONSIDERATIONS

The enclosure should be mounted:

- Upright in such a way that the screen is clearly visible and the keypad is easy to access. Recommended mounting height is 1.5m (5ft) above ground.
- Near to the appliance being controlled in order to minimize cable run lengths to the valve train (solenoids), burner assembly (ignition coil and flame rod) and thermocouple elements.
- In such a way as to avoid direct sunlight exposure on the screen. Extended UV exposure may compromise viewability.
- Such that the enclosure door can be fully opened during maintenance and commissioning.

6.2 CONNECTION DIAGRAMS



Caution: Electrical devices connected to the controller must meet local electrical codes and be within the voltage limits specified in this manual.



Caution: All field wiring must be properly fused and sized in accordance with local codes.



Caution: Wires must be installed such that the connection does not rely on the structural integrity of the wire insulation, and that no more than one conductor is terminated in a single terminal.

6.2.1 DIGITAL INPUT - DRY CONTACT

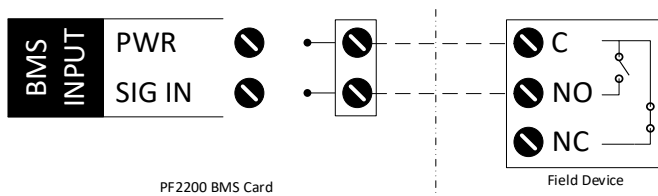

Installation Notes:

1. The BMS uses energized-to-run logic for all digital inputs.
2. PWR terminal output matches system voltage input up to 12V_{DC} in 12V Mode and up to 13.5V in 24V Mode.

6.2.2 DIGITAL INPUT - WET CONTACT

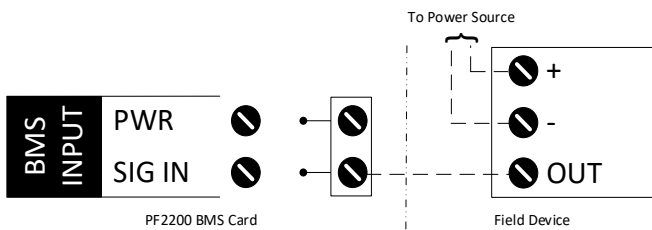

Installation Notes:

1. The BMS uses energized-to-run logic for all digital inputs.
2. External power source must be Earth grounded.
3. External power source must be referenced about BMS card terminal 29 such that the supplied voltage (1) does not exceed 30V_{DC} with reference to BMS Power In -, and (2) does not drop below -0.5V with reference to BMS Power In -.

6.2.3 ANALOG INPUT - LOOP POWERED 4-20mA TRANSMITTER

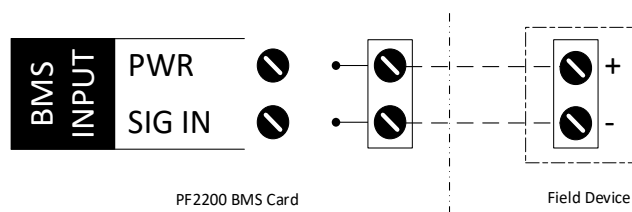

Installation Notes:

1. PWR terminal output matches system voltage input up to 12V_{DC} in 12V Mode and up to 13.5V in 24V Mode.

6.2.4 ANALOG INPUT – SELF POWERED 4-20mA TRANSMITTER

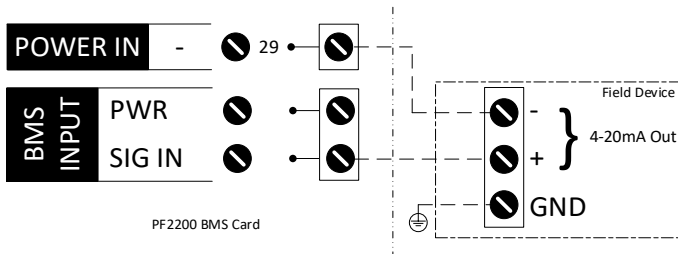

Installation Notes:

1. Field Device must be Earth grounded.
2. Power source must be referenced about BMS card terminal 29 such that the supplied voltage (1) does not exceed 30V_{DC} with reference to BMS Power In -, and (2) does not drop below -0.5V with reference to BMS Power In -.

6.2.5 ANALOG INPUT – INPUT FROM PLC

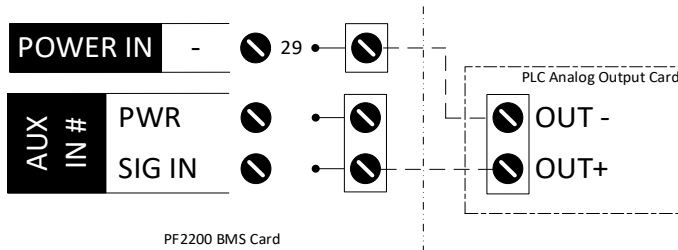

Installation Notes:

1. PLC power source must be referenced about BMS card terminal 29 such that the supplied voltage (1) does not exceed 30V_{DC} with reference to BMS Power In -, and (2) does not drop below -0.5V with reference to BMS Power In -.

6.2.6 TCV OUTPUT WIRING

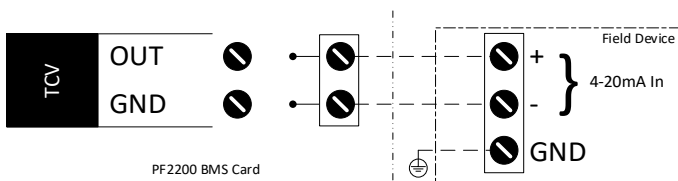

Installation Notes:

1. 4-20mA Input – terminal must be run back to BMS TCV local ground terminal (GND) to ensure proper output functionality.

6.2.7 SOLENOID OUTPUT – 12V/24V

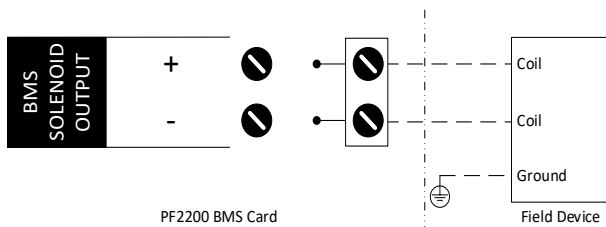

Installation Notes:

1. Solenoid powered outputs are rated to 5A max individually, however the power input to the BMS is fused at 10A. Care must be taken as to not exceed the 10A max input when using multiple high-powered solenoids.
2. Solenoid valve outputs are assumed to be in safe state when de-energized. Normally closed valves must be used such that gas-flow to the burner is stopped when the output is in the de-energized state. Solenoid valve outputs can also be connected to normally open bleed valves when utilizing a double block and bleed configuration.





Caution: Do not connect solenoid device minus (-) terminals to ground, as the BMS solenoid output minus (-) terminals are not grounded.

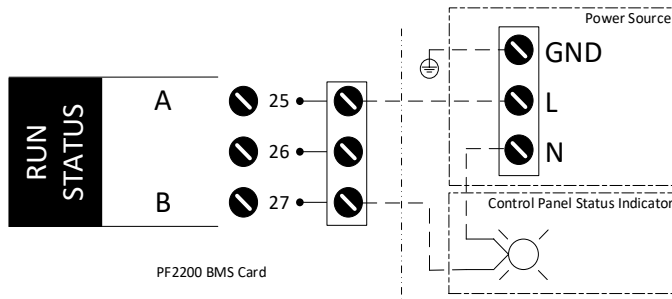

Caution: Do not jumper solenoid minus terminals together under any circumstance, as this will compromise the safety integrity of the system.

6.2.8 RUN STATUS – EXTERNAL AC SOURCE





Warning: 120VAC wiring should be installed by a qualified electrician.

6.2.9 RUN STATUS – EXTERNAL DC SOURCE

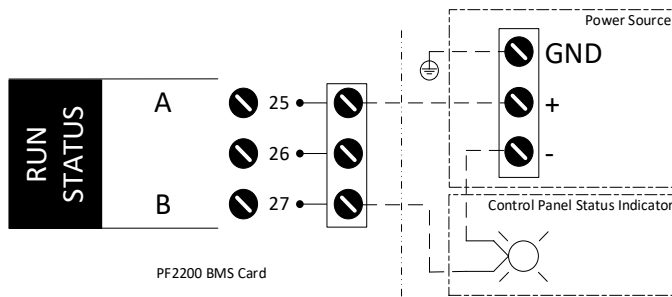

6.2.10 RUN STATUS – BMS POWER

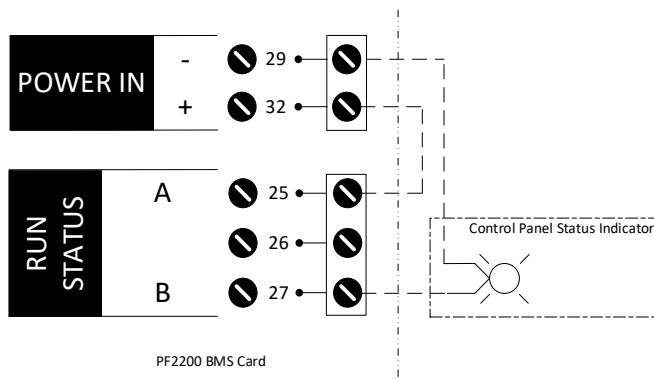

6.2.11 RUN STATUS – PUMP CONTROL

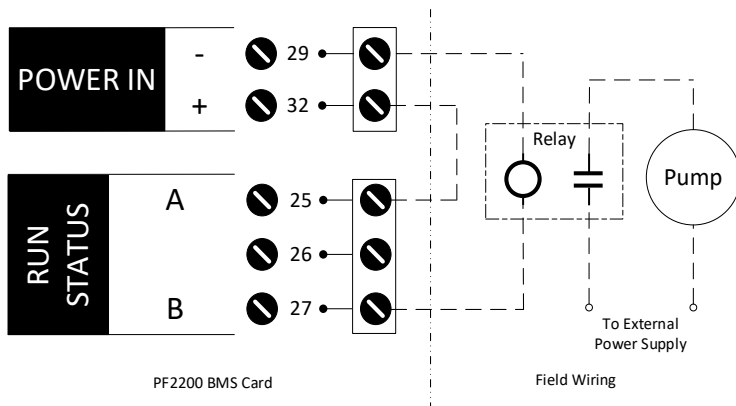

Installation Notes:

1. A relay must be used to isolate the Run Status contact from high-transient currents associated with motors and pumps.



Warning: 120VAC wiring should be installed by a qualified electrician.

6.2.12 POWER INPUT WIRING

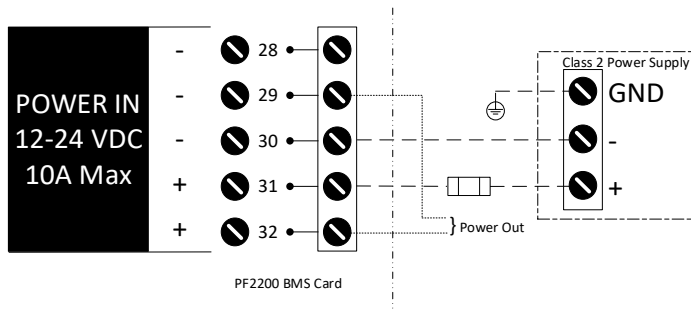

6.2.13 ANALOG OUTPUT – 4-20mA ECHO TO PLC

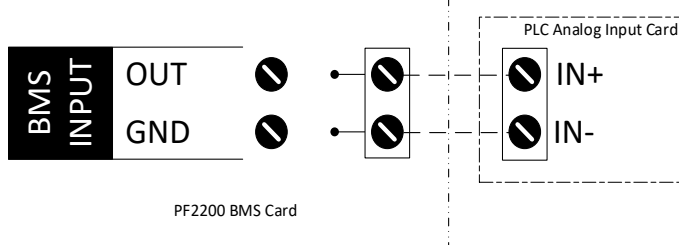

Installation Notes:

1. 4-20mA Input IN- terminal must be run back to BMS Input GND terminal (Local ground) to ensure proper output functionality.

6.2.14 UPSTREAM PROOF OF CLOSURE WIRING

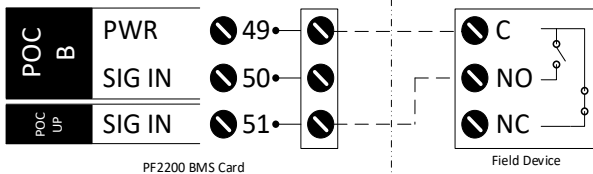

Installation Notes:

1. Ensure that no more than one conductor is terminated in a single terminal.

6.2.15 SINGLE ROD IGNITION WIRING

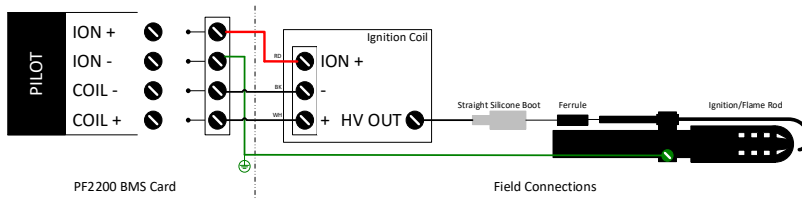

Installation Notes:

1. The wire length between the ignition coil and pilot should be no more than 5m (15ft).
2. For long run lengths connect burner housing to ION - terminal with ignition cable to avoid ground-loading



Warning: Failure to provide a low-impedance path from the burner assembly to the PF2200 may result in electric shock, product damage, failure to ignite the pilot, or failure to detect flame.

6.2.16 DUAL ROD IGNITION WIRING

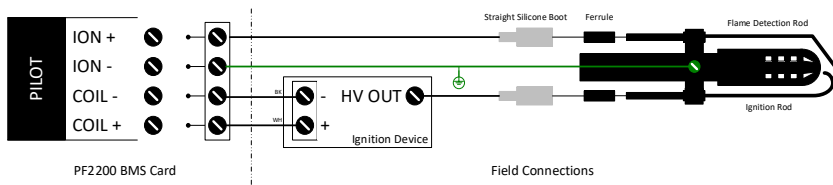

Installation Notes:

1. The wire length between the ignition coil and pilot should be no more than 5m (15ft).
2. For long run lengths connect burner housing to ION - terminal with ignition cable to avoid ground-loading



Warning: Failure to provide a low-impedance path from the burner assembly to the PF2200 may result in electric shock, product damage, failure to ignite the pilot, or failure to detect flame.

6.2.17 TEMPERATURE INPUT- DUAL TYPE K THERMOCOUPLE

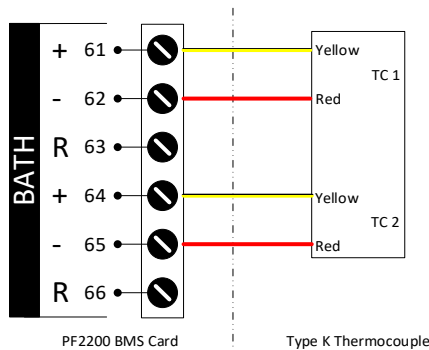

Installation Notes:

1. Thermocouple must be grounded or ungrounded Type K.
2. Thermocouple wire run lengths should be minimized where possible.
3. Thermocouple wires should not be run in the same conduit as high-noise signals (e.g. valve wires, motor wires, etc.)

6.2.18 TEMPERATURE INPUT- DUAL 3-WIRE RTD

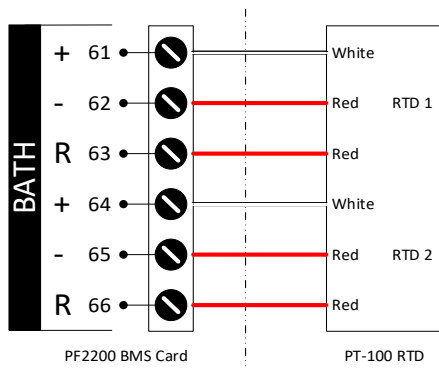

6.2.19 TEMPERATURE INPUT- SINGLE TYPE K THERMOCOUPLE

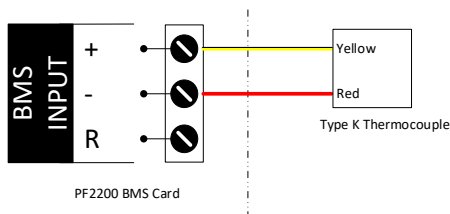

Installation Notes:

1. Thermocouple must be grounded or ungrounded Type K.
2. Thermocouple wire run lengths should be minimized where possible.
3. Thermocouple wires should not be run in the same conduit as high-noise signals (e.g. valve wires, motor wires, etc.)

6.2.20 TEMPERATURE INPUT- SINGLE 3-WIRE RTD

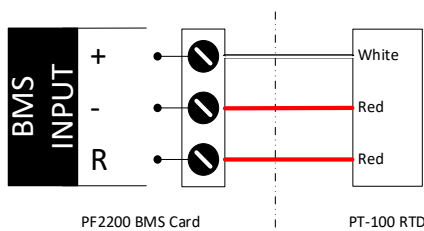

6.2.21 MODBUS INPUT WIRING

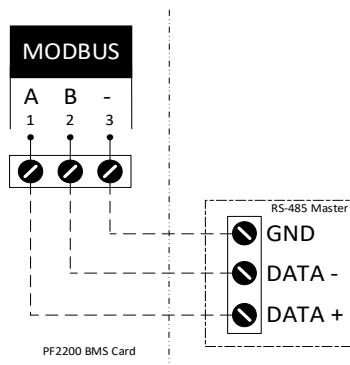

Installation Notes:

1. Modbus wires should not be run in the same conduit as high-noise signals (e.g. valve wires, motor wires, etc.)

7 SYSTEM CONFIGURATION

The following section describes each configuration setting found in the menus of the PF2200-DB. All settings changes must be verified prior to starting the system and functional tests must be performed to ensure that all expected alerts ring in correctly. The best way to verify the system configuration is to manually force an alarm condition on each connected input or output device independently and verify that the system annunciates the appropriate alarm.



Warning: System settings must only be modified by qualified personnel who have an understanding of the appliance under control and its effect on the other plant processes.

7.1 TEMPERATURES

7.1.1 BATH INPUT

Name	Default	Options / Range	Description
Type	RTD	TC RTD	Temperature sensing element type. Type K Thermocouple (grounded or ungrounded) or PT100 RTD.
Input	Dual	Dual Single	Configuration control for the Bath input. Dual requires two unique temperature sensing elements, whereas single only requires one.
Input setting is required to be set to Dual if the Bath Input is specified as a safety function.			
Mode	Process Control	Process Control High Temp ESD	Mode for the temperature input, used by the system to determine how the input is to be used.
At least one of Bath Mode, Outlet Mode or Aux Temp Mode must be set to Process Control			
High Temp Setpoint	90 °C 194 °F	0 °C - 1350 °C 32 °F - 2462 °F	Temperature threshold at which the system shuts down.
High Temp Setpoint must be greater than Pilot Off Setpoint and If Type setting is set to RTD, High Temp Setpoint must be less than 850 °C (1562 °F)			
Pilot Off Setpoint	85 °C 185 °F	0 °C - 1350 °C 32 °F - 2462 °F	Temperature threshold at which the system turns off the pilot valve(s).
Pilot Off Setpoint must be greater than Main Off Setpoint and less than High Temp Setpoint			
Main Off Setpoint	85 °C 185 °F	0 °C - 1350 °C 32 °F - 2462 °F	Temperature threshold at which the system turns off the main valve(s).
Main Off Setpoint must be greater than Process Setpoint and less than Pilot Off Setpoint			
Process Setpoint	80 °C 176 °F	0 °C - 1350 °C 32 °F - 2462 °F	Temperature that the system attempts to maintain when in Process Control mode.
Process Setpoint must be greater than Low Temp Setpoint and less than Main Off Setpoint			
Low Temp Setpoint	0 °C 32 °F	0 °C - 1350 °C 32 °F - 2462 °F	Temperature threshold at which, if not exceeded, the system warns the user.
Low Temp Setpoint must be less than Process Setpoint			
Deadband	2 °C 3.6 °F	0 °C - 100 °C 0 °F - 180 °F	The deadband prevents bouncing between states when the input reading is close to the corresponding setpoint.

7.1.2 OUTLET / STACK B INPUT

Name	Default	Options / Range	Description
Type	RTD	TC RTD	Temperature sensing element type. Can be Type K Thermocouple (grounded or ungrounded) or PT100 RTD.
Mode	Disabled	Disabled Outlet Process Control Outlet High Temp ESD Outlet Display Only Stack B High Temp ESD Stack B Display Only	Mode for the temperature input, used by the system to determine how the input is to be used. See Temperature Inputs section for more details.
At least one of Bath Mode, Outlet Mode or Aux Temp Mode must be set to Process Control			
High Temp Setpoint	90 °C 194 °F	0 °C - 1350 °C 32 °F - 2462 °F	Temperature threshold at which the system acts on an Outlet/ Stack B high trip event.
Only applicable if the mode is set to High Temp ESD or Process Control. High Temp must be greater than Pilot Off Setpoint AND If Type is RTD, must be less than 850 °C (1562 °F)			
Pilot Off Setpoint	85 °C 185 °F	0 °C - 1350 °C 32 °F - 2462 °F	Temperature threshold at which the system will turn off the pilot valve(s).
Pilot Off Setpoint must be greater than Main Off Setpoint and less than High Temp Setpoint			
Main Off Setpoint	85 °C 185 °F	0 °C - 1350 °C 32 °F - 2462 °F	Temperature threshold at which the system will turn off the main valve(s).
Main Off Setpoint must be greater than Process Setpoint and less than Pilot Off Setpoint			
Process Setpoint	80 °C 176 °F	0 °C - 1350 °C 32 °F - 2462 °F	Temperature that the system attempts to maintain when in Process Control mode.
Process Setpoint must be greater than Low Temp Setpoint and less than Main Off Setpoint			
Low Temp Setpoint	0 °C 32 °F	0 °C - 1350 °C 32 °F - 2462 °F	Temperature threshold at which, if not exceeded, the system will warn the user.
Low Temp Setpoint must be less than Process Setpoint			
Deadband	2 °C 3.6 °F	0 °C - 100 °C 0 °F - 180 °F	The deadband prevents bouncing between states when the input reading is close to the corresponding setpoint.

7.1.3 STACK INPUT

Name	Default	Options / Range	Description
Type	RTD	TC RTD	Temperature sensing element type
Mode	Disabled	Disabled High Temp ESD Display Only	Mode for the temperature input, used by the system to determine how the input is to be used.
High Temp Setpoint	90 °C 194 °F	0 °C - 1350 °C 32 °F - 2462 °F	Temperature threshold at which the system acts on a Stack/ Stack A high trip event.
Only applicable if the mode is set to High Temp ESD If Type is RTD, High Temp Setpoint must be less than 850 °C (1562°F)			
Deadband	2 °C 3.6 °F	0 °C - 100 °C 0 °F - 180 °F	The deadband prevents bouncing between states when the input reading is close to the corresponding setpoint.

7.1.4 AUX TEMP INPUT

Name	Default	Options / Range	Description
Mode	Disabled	Disabled Process Control High Temp ESD Display Only	Mode for the temperature input, used by the system to determine how the input is to be used. See Temperature Inputs section for more details.
At least one of Bath Mode, Outlet Mode or Aux Temp Mode must be set to Process Control			
High Temp Setpoint	90 °C 194 °F	0 °C - 1350 °C 32 °F - 2462 °F	Temperature threshold at which, if exceeded, the system will shut down.
Only applicable if the mode is set to High Temp ESD or Process Control. High Temp Setpoint must be greater than Pilot Off Setpoint			
Pilot Off Setpoint	85 °C 185 °F	0 °C - 1350 °C 32 °F - 2462 °F	Temperature threshold at which the system will turn off the pilot valve(s).
Pilot Off Setpoint must be greater than Main Off Setpoint and less than High Temp Setpoint			
Main Off Setpoint	85 °C 185 °F	0 °C - 1350 °C 32 °F - 2462 °F	Temperature threshold at which the system will turn off the main valve(s).
Main Off Setpoint must be greater than Process Setpoint and less than Pilot Off Setpoint			
Process Setpoint	80 °C 176 °F	0 °C - 1350 °C 32 °F - 2462 °F	Temperature that the system attempts to maintain when in Process Control mode.
Process Setpoint must be greater than Low Temp Setpoint and less than Main Off Setpoint			
Low Temp Setpoint	0 °C 32 °F	0 °C - 1350 °C 32 °F - 2462 °F	Temperature threshold at which, if not exceeded, the system will warn the user.
Low Temp Setpoint must be less than Process Setpoint			
Deadband	2 °C 3.6 °F	0 °C - 100 °C 0 °F - 180 °F	The deadband prevents bouncing between states when the input reading is close to the corresponding setpoint.
4-20 Span Min	0 °C 32 °F	-100 °C - 1350 °C -148 °F - 2462 °F	Temperature value corresponding to 4mA output from the 4-20mA transmitter.
Span Min must be less than Span Max and Low Temp Setpoint			
4-20 Span Max	1350 °C 2462 °F	-100 °C - 1350 °C -148 °F - 2462 °F	Temperature value corresponding to 20mA output from the 4-20mA transmitter.
Span Max must be greater than Span Min and High Temp Setpoint			

7.2 INPUTS

7.2.1 LEVEL/FLOW INPUT

Name	Default	Options / Range	Description
Type	Digital	Disabled Digital 4-20	Level/Flow sensor type. Can be configured as a switch (digital), transmitter (4-20), or disabled.
Digital Mode	Alarm	Alarm Wait Warning	Action the system will take when a de-energized contact occurs.
Type must be set to Digital			
4-20 Low Trip Mode	Alarm	Alarm Wait Warning	Action the system will take when a low-trip event occurs.
Type must be set to 4-20			
4-20 High Trip Mode	Alarm	Alarm Wait Warning	Action the system will take when a high-trip event occurs.
Type must be set to 4-20			
4-20 Low Trip Setpoint	60 L 15.9 gal	Span Min to Max	Input threshold at which the system will initiate a low-trip event in accordance with the 4-20 Low Trip Mode setting.
Type must be set to 4-20			
4-20 High Trip Setpoint	117 L 30.9 gal	Span Min to Max	Input threshold at which the system will initiate a high-trip event in accordance with the 4-20 High Trip Mode setting.
Type must be set to 4-20			
4-20 Deadband	1.5 L 0.4 gal	0 - 6.25% of Span	The deadband prevents bouncing between states when the input reading is close to the corresponding trip point.
To clear a low trip, input must be greater than 4-20 Low Trip plus deadband.			
To clear a high trip, input must be less than 4-20 High Trip minus deadband.			
4-20 Span Min	0 L 0 gal	0 - 10000000 L 0 - 2641720 gal	Level/Flow value corresponding to 4mA output from the 4-20mA transmitter.
Span Min must be less than Span Max and 4-20 Low Trip			
4-20 Span Max	120 L 31.7 gal	0 - 10000000 L 0 - 2641720 gal	Level/Flow value corresponding to 20mA output from the 4-20mA transmitter.
Span Max must be greater than Span Min and 4-20 High Trip			
Level/Flow Delay	2 sec	2 sec - 20 sec	The amount of time the system requires a low-input event be present before taking action.

7.2.2 PRESSURE UP INPUT

Name	Default	Options / Range	Description
Type	Digital	Disabled Digital 4-20	Upstream pressure sensor type.
Digital Type	Low	Low High	Digital upstream pressure device type
Type must be set to Digital			
4-20 Low Trip	0 kPa 0 psi	Span Min to Max	Input threshold at which the system will initiate a low-trip event in accordance with the Low Pressure Mode setting.
Type must be set to 4-20			
4-20 High Trip	178 kPa 25.7 psi	Span Min to Max	Pressure threshold that, if exceeded, the system will shutdown.
Type must be set to 4-20			
4-20 Deadband	2.6 kPa 0.4 psi	0 – 6.25% of span	The deadband prevents bouncing between states when the input reading is close to the corresponding trip point.
To clear a low trip, input must be greater than 4-20 Low Trip plus deadband.			
To clear a high trip, input must be less than 4-20 High Trip minus deadband.			
4-20 Span Min	0 kPa 0 psi	0 - 100000 kPa 0 psi - 14504 psi	Pressure value corresponding to 4mA output from the 4-20mA transmitter.
Span Min must be less than Span Max and 4-20 Low Trip			
4-20 Span Max	207 kPa 30 psi	0 - 100000 kPa 0 psi - 14504 psi	Pressure value corresponding to 20mA output from the 4-20mA transmitter.
Span Max must be greater than Span Min and 4-20 High Trip			
Low Pressure Mode	Alarm	Alarm Wait Warning Main Permissive	Action the system will take when a low-pressure event occurs.
Low Pressure Delay	2 sec	2 sec - 20 sec	The amount of time a low-pressure condition must be present before the system takes any action.

7.2.3 PRESSURE A INPUT

Name	Default	Options / Range	Description
Type	Digital	Disabled Digital 4-20	Burner A Pressure sensor type.
4-20 Low Trip	0 kPa 0 psi	Span Min to Max	Input threshold at which the system will initiate a low-trip event in accordance with the Low Pressure Mode setting.
Type must be set to 4-20			
4-20 High Trip	178 kPa 25.7 psi	Span Min to Max	Pressure threshold that, if exceeded, the system will shutdown.
Type must be set to 4-20			
4-20 Deadband	2.6 kPa 0.4 psi	0 - 6.25% of span	The deadband prevents bouncing between states when the input reading is close to the corresponding trip point.
To clear a low trip, input must be greater than 4-20 Low Trip plus deadband.			
To clear a high trip, input must be less than 4-20 High Trip minus deadband.			
4-20 Span Min	0 kPa 0 psi	0 - 100000 kPa 0 psi - 14504 psi	Pressure value corresponding to 4mA output from the 4-20mA transmitter.
Span Min must be less than Span Max and 4-20 Low Trip			
4-20 Span Max	207 kPa 30 psi	0 - 100000 kPa 0 psi - 14504 psi	Pressure value corresponding to 20mA output from the 4-20mA transmitter.
Span Max must be greater than Span Min and 4-20 High Trip			
4-20 Low Pressure Mode	Alarm	Alarm Wait Warning Main Permissive	Action the system will take when a 4-20 low-pressure event occurs.
Type must be set to 4-20			
Low Pressure Delay	2 sec	2 sec - 20 sec	The amount of time a low-pressure condition must be present before the system takes any action.

7.2.4 PRESSURE B INPUT

Name	Default	Options / Range	Description
Type	Digital	Disabled Digital 4-20	Burner B Pressure sensor type.
4-20 Low Trip	0 kPa 0 psi	Span Min to Max	Input threshold at which the system will initiate a low-trip event in accordance with the Low Pressure Mode setting.
Type must be set to 4-20			
4-20 High Trip	178 kPa 25.7 psi	Span Min to Max	Pressure threshold that, if exceeded, the system will shutdown.
Type must be set to 4-20			
4-20 Deadband	2.6 kPa 0.4 psi	0 – 6.25% of span	The deadband prevents bouncing between states when the input reading is close to the corresponding trip point.
To clear a low trip, input must be greater than 4-20 Low Trip plus deadband. To clear a high trip, input must be less than 4-20 High Trip minus deadband.			
4-20 Span Min	0 kPa 0 psi	0 - 100000 kPa 0 psi - 14504 psi	Pressure value corresponding to 4mA output from the 4-20mA transmitter.
Span Min must be less than Span Max and 4-20 Low Trip			
4-20 Span Max	207 kPa 30 psi	0 - 100000 kPa 0 psi - 14504 psi	Pressure value corresponding to 20mA output from the 4-20mA transmitter.
Span Max must be greater than Span Min and 4-20 High Trip			
4-20 Low Pressure Mode	Alarm	Alarm Wait Warning Main Permissive	Action the system will take when a 4-20 low-pressure event occurs.
Type must be set to 4-20			
Low Pressure Delay	2 sec	2 sec - 20 sec	The amount of time a low-pressure condition must be present before the system takes any action.

7.2.5 REMOTE START INPUT

Name	Default	Options / Range	Description
Remote Start	Disabled	Disabled Enabled	Controls whether the Remote Start input is enabled or disabled.

7.2.6 PROOF OF CLOSURE INPUTS

Name	Default	Options / Range	Description
Proof of Closure Upstream	Enabled	Disabled Enabled	Controls whether the Upstream Proof of Closure input is used.
Proof of Closure A	Enabled	Disabled Enabled	Controls whether the Burner A Proof of Closure input is used.
Proof of Closure B	Enabled	Disabled Enabled	Controls whether the Burner B Proof of Closure input is used.

7.2.7 AUX IN 1 & AUX IN 2 INPUTS

Name	Default	Options / Range	Description
Type	Digital	Disabled Digital 4-20	Input sensor type.
Mode	High/Low Trip	High/Low Trip Burner A High/Low Trip Burner B High/Low Trip Appliance Firing Rate Bath Process SP Adjust Outlet Process SP Adjust Aux Temp Process SP Adjust	Defines the scope/mode of the Auxiliary inputs
Digital Trip Mode	Alarm	Alarm Wait Warning Main Permissive	Defines the system behavior for a de-energized digital input
Type must be set to Digital			
4-20 Low Trip Mode	Alarm	Alarm Wait Warning Main Permissive	Defines the system behavior for 4-20 low-trip events.
Type must be set to 4-20			
4-20 High Trip Mode	Alarm	Alarm Wait Warning Main Permissive	Defines the system behavior for 4-20 high-trip events.
Type must be set to 4-20			
4-20 Low Trip Setpoint	0%	0 - 100%	Input threshold at which the system will initiate a low-trip event in accordance with the 4-20 Low Trip Mode setting.
Type must be set to 4-20			
4-20 High Trip Setpoint	100%	0 - 100%	Input threshold at which the system will initiate a high-trip event in accordance with the 4-20 High Trip Mode setting.
Type must be set to 4-20			
4-20 Deadband	1.2%	0 - 100%	The deadband prevents the system from bouncing between states when the input reading is close to the corresponding trip point.
Type must be set to 4-20			
To clear a low trip, input must be greater than 4-20 Low Trip plus deadband.			
To clear a high trip, input must be less than 4-20 High Trip minus deadband.			
4-20 Span Min	0%	0% - 100%	Input value corresponding to 4mA output from the 4-20mA transmitter.
Type must be set to 4-20			
Span Max must be greater than Span Min			
4-20 Span Max	100%	0% - 100%	Input value corresponding to 20mA output from the 4-20mA transmitter.
Type must be set to 4-20			
Span Max must be greater than Span Min			

7.3 PROCESS CONTROL

7.3.1 CONFIGURATION

Name	Default	Options / Range	Description
Process Control Mode	Bath PID Control	On/Off Control Bath PID Control Outlet PID Control Aux PID Control Cascaded PID Control Firing Rate	Control mode of the system.
Pilot Off Mode	Disabled	Disabled Off at Pilot Off Setpoint Off at Main Off Setpoint	Defines when the system turns off the Pilot valve while running:
Minimum Burners Running	1	1 2	Specifies the number of burners that must be running for the system to remain running.
Valve Sync	Disabled	Enabled Disabled	Specifies whether the burners must synchronize states.

7.3.2 TIMING

Name	Default	Options / Range	Description
Purge Time	60 sec	10 sec – 900 sec	Specifies the duration of purging.
Pilot Startup Delay Time	15 sec	5 sec – 900 sec	Time that the system will hold in the Pilot state before transitioning to a higher heat demand state
Main Startup Delay Time	30 sec	30 sec – 600 sec	Time that the system will hold in Main with the TCV at its Minimum position before transitioning to a Process Control state.
Request Light Off Delay Time	30 sec	10 sec – 600 sec	Time that the system will allow for the TCV to reach its Minimum Position in the Requesting Light Off state.

7.3.3 IGNITION

Name	Default	Options / Range	Description
Ignition Mode	Coil	Coil HEI	Controls the Coil output behavior when in the ignition state: Coil: Pulsed output mode HEI: constant output mode
Relight Attempts	3	0 - 3 attempts	Determines the number of relight attempts allowed following a flame loss.

7.3.4 PID CONTROL

Name	Default	Options / Range	Description
Process Proportional Band	10 °C 18 °F	0 °C - 1000 °C 0 °F - 1800 °F	This is the proportional Band used for the PID calculation. In cascaded control mode this value applies to the bath PID loop.
Process Integral Time	4 mins/rep	0 - 1000 mins/rep	This is the integral time used for the PID calculation.
Process Derivative Time	0 min	0 min - 1000 min	This is the derivative time used for the PID calculation.
Process Integral Reset Range	10 °C 18 °F	0 °C - 1000 °C 0 °F - 1800 °F	Process temperature range in which the integral term will accumulate.
Cascade Proportional Band	10 °C 18 °F	0 °C - 1000 °C 0 °F - 1800 °F	Proportional Band setting for cascaded PID. Inputs > Process Control > Configuration > Process Control Mode must be set to Cascaded PID Control
Cascade Integral Time	0 mins/rep	0 mins/rep - 1000 mins/rep	Integral time setting for cascaded PID. Inputs > Process Control > Configuration > Process Control Mode must be set to Cascaded PID Control
Cascade Derivative Time	0 min	0 min - 1000 min	Derivative time setting for cascaded PID. Inputs > Process Control > Configuration > Process Control Mode must be set to Cascaded PID Control
Cascade Integral Reset Range	10 °C 18 °F	0 °C - 1000 °C 0 °F - 1800 °F	In cascaded mode this is the boundary of the integral windup range for the outlet temperature. If the outlet temperature is outside of this range the integral term will not accumulate.
Output Rate Limit	100 %/sec	0.1 - 100 %/sec	This is the limit for the maximum output change of the TCV per second. A larger value allows for a quicker change in output. A smaller value slows down any change in output. This can help prevent fast movements from the TCV.
Ramp Time	10 sec	0 sec - 255 sec	Specifies the rate at which the system will ramp the TCV output(s) to the requested firing rate upon entry into a Process Control state.

7.4 OUTPUTS

7.4.1 STATUS OUTPUT

Name	Default	Options / Range	Description
Status Contact Mode	Run Status	Run Status Heating Status Low Temp Warning Level/Flow Control	Defines the behavior of the Status Contact.

7.4.2 VALVES

Name	Default	Options / Range	Description
Pilot Valve A PWM	60%	1 % - 100 %	Duty cycle of the Pilot A valve output. Higher value corresponds to higher average output.
Pilot Valve B PWM	60%	1 % - 100 %	Duty cycle of the Pilot B valve output. Higher value corresponds to higher average output.
SSV A PWM	60%	1 % - 100 %	Duty cycle of the SSV A valve output. Higher value corresponds to higher average output.
SSV B PWM	60%	1 % - 100 %	Duty cycle of the SSV B valve output. Higher value corresponds to higher average output.
SSV Upstream PWM	60%	1 % - 100 %	Duty cycle of the SSV UP valve output. Higher value corresponds to higher average output.

7.4.3 AUX OUTPUT

Name	Default	Options / Range	Description
Mode	Disabled	Disabled Level/Flow Echo Aux In 1 Echo Aux In 2 Echo Modbus Echo Bath Temp Echo Outlet Temp Echo Stack Temp Echo Aux Temp Echo	Defines the behavior of the Auxiliary Output.
Temp Echo Span Min	0 °C 32 °F	-100 °C - 1350 °C -148 °F - 2462 °F	Temperature value corresponding to 4mA from the Auxiliary Output.
Span Max must be greater than Span Min			
Temp Echo Span Max	1350 °C 2462 °F	-100 °C - 1350 °C -148 °F - 2462 °F	Temperature value corresponding to 20mA from the Auxiliary Output.
Span Max must be greater than Span Min			

7.4.4 TCV OUTPUT

Name	Default	Options / Range	Description
Manual Override	Disabled	Disabled Enabled	Manual override of TCV outputs
Manual Position	0%	0 % - 100 %	Position of TCV outputs when Manual Override is enabled.
Min Position	40%	0 % - 70 %	Minimum position of the TCV output while in a Process Control state.
Purge Position	100%	0 % - 100 %	Position of the TCV output while system is purging.
Pilot Position	40%	0 % - 100 %	Position of the TCV output while in the Ignition or Pilot state.
Shared TCV (A)	Disabled	Disabled Enabled	Specifies whether a shared upstream TCV is connected to the TCV A output terminals.

7.5 SETUP

7.5.1 COMMISSIONING

Name	Default	Options / Range	Description
Voltage Setting	12V	12V 24V	Sets the expected input voltage for the system.
Voltage Restart	Disabled	Disabled Enabled	Allows the system to automatically restart after a low voltage event while running.
L1 Password Enable	Disabled	Disabled Enabled	Enabling this mode allows L1 password control on some non-safety critical settings.
Commissioning Complete	Incomplete	Incomplete Complete	Setting to confirm all commissioning checks have been performed.
Current Date/Time	Jan 1 2000 12:00 AM		Sets the date and time for accurate event and data logging.

7.5.2 UNITS

Name	Default	Options / Range	Description
Temperatures	Celsius	Celsius Fahrenheit	Display units for Temperature inputs.
Pressure	kPa	kPa psi inch wc oz/in ² kg/cm ² Percent Milliamps	Display units for Pressure inputs.
Level/Flow	Litres	Litres m ³ US Gallons bbl ft ³ L/sec L/min m ³ /sec m ³ /min US Gal/sec US Gal/min bbl/sec bbl/min ft ³ /sec ft ³ /min Percent Milliamps	Display units for Level/Flow input
Aux In	Percent	Percent Milliamps Temperature Pressure Level/Flow	Display units for Aux In 1 and Aux In 2 inputs (configured independently)

7.5.3 MODBUS

Name	Default	Options / Range	Description
RTU Communication	Disabled	Disabled Enabled	Enables or disables Modbus communication.
Termination	Disabled	Disabled Enabled	Enables or disables Modbus termination resistor.
Baud Rate	9600	9600 19200	Baud rate for the RS-485 link.
Stop Bits	1	1 2	Number of stop bits. Used for configuring the RS-485 protocol.
Parity	None	None Odd Even	Parity bit support. Used for configuring the RS-485 protocol.
Slave Address	1	1 - 247	Modbus slave address of the PF2200.

8 MAINTENANCE

8.1 TRANSPORTATION AND STORAGE CONDITIONS

Transportation of the product shall be in the original product packaging or equivalent. Transportation of cards without enclosure is not recommended and should be done with the utmost care utilizing an Anti-Static/ESD bag. Storage temperature should be kept within the operating temperature listed in Section 3 in a dry area. Avoid moisture buildup inside the enclosure.

8.2 REPAIR AND REPLACEMENT

Profire does not support on-site repairs for cards. For replacement cards contact Profire customer service. In the event replacement card(s) are used, care must be taken to ensure proper firmware is loaded on both the User Interface and BMS cards. If the User Interface and BMS cards have different software bundles loaded on them, the system will fail to operate correctly and will require a firmware update to match. BMS cards must be securely fastened into the back of the enclosure with six #10-32 machine screws. UI cards must not be removed from the enclosure door. Should a UI card replacement be required, an entire door assembly will be shipped.

8.3 DECOMMISSIONING

When decommissioning the system, the appliance should be safely shut down (i.e. all safety outputs are turned off and there are no gas leaks on site). Once the appliance is in a safe state, the power should be disconnected from the PF2200. All cards should be treated like any other piece of electronics (e.g. be sent to a recycling depot).

8.4 USEFUL LIFE

The useful life of the PF2200 is 10 years. Prior to the expiry of that period the customer should contact Profire for a suitable replacement.

8.5 MANUFACTURER NOTIFICATION

Any detected failures that compromise the functional safety of the system must be reported to Profire customer service immediately.



Warning: Do not modify any system wiring or handle the electronics while the system is powered.



Caution: Do not disassemble or modify the cards in any way. The cards are not field repairable and must be sent back to Profire for replacement if damaged.



Caution: The enclosure door must be securely closed after opening. Improper closure may result in moisture or other environmental damage and may compromise the integrity of the product.

9 TROUBLESHOOTING

Problem	Proposed Solutions
System has visible flame but cannot detect	<ol style="list-style-type: none"> 1. Ensure pilot assembly, flame rod, and the gap between are fully engulfed in flame. If not, adjust rod position 2. Ensure flame detection wiring does not exceed the recommended maximum length 3. Ensure burner assembly has a low impedance path to Ion- terminal of BMS 4. For longer run lengths, ensure ignition cable is used to avoid ground-loading
Card is unresponsive or BMS card will not communicate with User Interface card	<ol style="list-style-type: none"> 1. Ensure the Status LEDs for both cards are functioning. If status LED is not functioning, cycle power (if safe to do so) and check again. 2. Check the wiring between the BMS card and the User Interface Card. 3. Ensure that BMS card and UI card have matching firmware.
Ignition transformer "clicks" but no visible spark	<ol style="list-style-type: none"> 1. Ensure all wires in the ignition path are properly terminated and that there is a low impedance path from the primary-windings to the BMS card as well as the secondary-windings to the ignition rod. 2. Ensure the gap between the ignition rod and the burner housing is within the tolerances specified in the Product Declarations section under "High Voltage Spark Gap Range".
Solenoids are not turning on, or turning on then over time turn off	<ol style="list-style-type: none"> 1. Ensure the solenoid is wired correctly and to the appropriate terminals. To ensure proper solenoid wiring, a multi-meter in OHM mode can be used to measure the resistance between the + and - terminal of the associated output. Note: this measurement should be done with the BMS card powered off. If properly wired, the multi-meter should read a resistance of the solenoid coil plus the run length (i.e. if the multimeter reads open, there is likely a problem with wiring). 2. Ensure the PWM setting is correct for the appropriate solenoid. If using a peak-and-hold solenoid, the appropriate PWM setting can be found in the solenoid data sheet. Typically add a margin of 5-10% to allow for temperature variance. If using a non-peak-and-hold solenoid, ensure the PWM setting is set to 100%.
Digital input will not energize	<ol style="list-style-type: none"> 1. Ensure the input is properly wired. See Connection Diagrams section. In the case of a dry contact, ensure the PWR terminal is connected and is sourcing the correct voltage. 2. Ensure adequate amount of wetting current is being applied to through contact. Run a current meter in series with the digital input switch and verify the energized state meets the requirements outlined in the BMS Card Electrical Ratings section. If the wetting current is not adequate, the digital input either has too high of an impedance or the wiring has been compromised.

10 ALERT CODES & RESPONSE TIMES

10.1 ALARMS

ID	Name	Alarm Condition	Set
AL001	Upstream Proof of Closure Contact Open	POC UP input is open while SSV UP output de-energized	2s
AL002	Proof of Closure Contact A Open	POC A input is open while SSV A output de-energized	2s
AL003	Proof of Closure Contact B Open	POC B input is open while SSV B output de-energized	2s
AL004	ESD Contact Open	ESD input is open	1s
AL005	Upstream Pressure Out of Range	Upstream Pressure Input in 4-20 mode: Input is less than 3 mA OR greater than 21 mA Upstream Pressure Input in Digital mode: Input is not within valid range ^[1]	1s
AL006	Pressure A Out of Range	Burner A Pressure Input in 4-20 mode: Input is less than 3 mA OR greater than 21 mA Burner A Pressure Input in Digital mode: Input is not within valid range ^[1]	1s
AL007	Pressure B Out of Range	Burner B Pressure Input in 4-20 mode: Input is less than 3 mA OR greater than 21 mA Burner B Pressure Input in Digital mode: Input is not within valid range ^[1]	1s
AL008	Low Upstream Pressure	Upstream Pressure Input in 4-20 mode: Input is less than Low Trip setting Upstream Pressure Input in Digital low-pressure mode: Input is open Upstream Pressure Input in Digital high-pressure mode: This alarm cannot be set	Pressure Up Delay setting
AL009	Low Pressure A	Burner A Pressure Input in 4-20 mode: Input is less than Low Trip setting Burner A Pressure Input in Digital mode: This alarm cannot be set	Pressure A Delay setting
AL010	Low Pressure B	Burner B Pressure Input in 4-20 mode: Input is less than Low Trip setting Burner B Pressure Input in Digital mode: This alarm cannot be set	Pressure B Delay setting
AL011	High Upstream Pressure	Upstream Pressure Input in 4-20 mode: Input is greater than High Trip setting and SSV UP output energized Upstream Pressure Input in Digital high-pressure mode: Input is open and SSV UP output energized Upstream Pressure Input in Digital low-pressure mode: This alarm cannot be set	2s
AL012	High Pressure A	Burner A Pressure Input in 4-20 mode: Input is greater than High Trip setpoint AND SSV A output energized Burner A Pressure Input in Digital mode: Input is open	2s
AL013	High Pressure B	Burner B Pressure Input in 4-20 mode: Input is greater than High Trip setpoint AND SSV B output energized Burner B Pressure Input in Digital mode: Input is open	2s
AL014	Upstream Pressure Configuration Error	Upstream Pressure High Trip setting is less than Low Trip plus Deadband OR Upstream Pressure Span Max is less than Span Min	0
AL015	Pressure A Configuration Error	Burner A Pressure High Trip setting is less than Low Trip plus Deadband OR Burner A Pressure Span Max is less than Span Min	0
AL016	Pressure B Configuration Error	Burner B Pressure High Trip setting is less than Low Trip plus Deadband OR Burner B Pressure Span Max is less than Span Min	0
AL017	Level/Flow Out of Range	Level/Flow Input in 4-20 mode: Input is less than 3 mA OR greater than 21 mA Level/Flow Input in Digital mode: Input is not within a valid range ^[1]	1s
AL018	Low Level/Flow	Level Input in 4-20 mode: Input is less than Level Low Trip setting Level Input in Digital mode: Input is open	Level/Flow Delay setting
AL019	High Level/Flow	Level input in 4-20 mode: Input is greater than Level High Trip Level input in Digital mode: This alarm cannot be set	Level/Flow Delay setting
AL020	Level/Flow Configuration Error	Level High Trip setting is less than Level Low Trip plus Level Deadband OR Level Span Max less than Level Span Min	0
AL021	Aux In 1 Out of Range	Aux In 1 Input in 4-20 mode: Input is less than 3 mA OR greater than 21 mA Aux In 1 Input in Digital mode: Input is not within a valid range ^[1]	1s
AL022	Aux In 1 Contact Open A	Aux In 1 input in 4-20 mode: This alarm cannot be set Aux In 1 input as Burner A alarm in Digital mode: Input is open	2s
AL023	Aux In 1 Low Trip A	Aux In 1 Input as Burner A alarm in 4-20 mode: Input is less than Low Trip setting Aux In 1 Input in Digital mode: This alarm cannot be set	2s
AL024	Aux In 1 High Trip A	Aux In 1 Input as Burner A alarm in 4-20 mode: Input is greater than High Trip setting Aux In 1 Input in Digital mode: This alarm cannot be set	2s
AL025	Aux In 1 Contact Open B	Aux In 1 input in 4-20 mode: This alarm cannot be set Aux In 1 input as Burner B alarm in Digital mode: Input is open	2s
AL026	Aux In 1 Low Trip B	Aux In 1 Input as Burner B alarm in 4-20 mode: Input is less than Low Trip setting Aux In 1 Input in Digital mode: This alarm cannot be set	2s
AL027	Aux In 1 High Trip B	Aux In 1 Input as Burner B alarm in 4-20 mode: Input is greater than High Trip setting Aux In 1 Input in Digital mode: This alarm cannot be set	2s
AL028	Aux In 1 Contact Open	Aux In 1 input in 4-20 mode: This alarm cannot be set Aux In 1 input as shared appliance alarm in Digital mode: Input is open	2s

ID	Name	Alarm Condition	Set
AL029	Aux In 1 Low Trip	Aux In 1 Input as shared appliance alarm in 4-20 mode: Input is less than Low Trip setting Aux In 1 Input in Digital mode: This alarm cannot be set	2s
AL030	Aux In 1 High Trip	Aux In 1 Input as shared appliance alarm in 4-20 mode: Input is greater than High Trip setting Aux In 1 Input in Digital mode: This alarm cannot be set	2s
AL031	Aux In 1 4-20 Configuration Error	Aux In 1 Input High Trip less than Input Low Trip plus Input Deadband OR Input Span Max less than Input Span Min OR Input High Trip greater than Input Span Max OR Input Low Trip less than Input Span Min	0
AL032	Aux In 1 Type/Mode Configuration Error	Aux In 1 input Type is Digital and Mode is Appliance Firing Rate OR Aux In 1 input Type is Digital and Mode is Process Setpoint Adjust	0
AL033	Aux In 2 Out of Range	Aux In 2 Input in 4-20 mode: Input is less than 3 mA OR greater than 21 mA Aux In 2 Input in Digital mode: Input is not within a valid range ^[1]	1s
AL034	Aux In 2 Contact Open A	Aux In 2 input in 4-20 mode: This alarm cannot be set Aux In 2 input as Burner A alarm in Digital mode: Input is open	2s
AL035	Aux In 2 Low Trip A	Aux In 2 Input as Burner A alarm in 4-20 mode: Input is less than Low Trip setting Aux In 2 Input in Digital mode: This alarm cannot be set	2s
AL036	Aux In 2 High Trip A	Aux In 2 Input as Burner A alarm in 4-20 mode: Input is greater than High Trip setting Aux In 2 Input in Digital mode: This alarm cannot be set	2s
AL037	Aux In 2 Contact Open B	Aux In 2 input in 4-20 mode: This alarm cannot be set Aux In 2 input as Burner B alarm in Digital mode: Input is open	2s
AL038	Aux In 2 Low Trip B	Aux In 2 Input as Burner B alarm in 4-20 mode: Input is less than Low Trip setting Aux In 2 Input in Digital mode: This alarm cannot be set	2s
AL039	Aux In 2 High Trip B	Aux In 2 Input as Burner B alarm in 4-20 mode: Input is greater than High Trip setting Aux In 2 Input in Digital mode: This alarm cannot be set	2s
AL040	Aux In 2 Contact Open	Aux In 2 input in 4-20 mode: This alarm cannot be set Aux In 2 input as shared appliance alarm in Digital mode: Input is open	2s
AL041	Aux In 2 Low Trip	Aux In 2 Input as shared appliance alarm in 4-20 mode: Input is less than Low Trip setting Aux In 2 Input in Digital mode: This alarm cannot be set	2s
AL042	Aux In 2 High Trip	Aux In 2 Input as shared appliance alarm in 4-20 mode: Input is greater than High Trip setting Aux In 2 Input in Digital mode: This alarm cannot be set	2s
AL043	Aux In 2 4-20 Configuration Error	Aux In 2 Input High Trip less than Input Low Trip plus Input Deadband OR Input Span Max less than Input Span Min OR Input High Trip greater than Input Span Max OR Input Low Trip less than Input Span Min	0
AL044	Aux In 2 Type/Mode Configuration Error	Aux In 2 input Type is Digital and Mode is Appliance Firing Rate OR Aux In 2 input Type is Digital and Mode is Process Setpoint Adjust	0
AL045	Multiple Appliance Firing Rates Configured	Aux In 1 and Aux In 2 are both configured as External Firing Rate inputs	2s
AL046	Multiple Bath SP Adjusts Configured	Aux In 1 and Aux In 2 are both configured as Bath Process Setpoint Adjust inputs	2s
AL047	Multiple Outlet SP Adjusts Configured	Aux In 1 and Aux In 2 are both configured as Outlet Process Setpoint Adjust inputs	2s
AL048	Multiple Aux Temp SP Adjusts Configured	Aux In 1 and Aux In 2 are both configured as Aux Temp Process Setpoint Adjust inputs	2s
AL049	Process Setpoint Adjust Setpoint Configuration Error	Aux In 1 or 2 is configured as Process Setpoint Adjust input AND Associated temperature input mode is not set to Process Control	0
AL050	Bath High Temp ESD	Bath Temperature Input is greater than High Temp ESD setpoint	2s
AL051	Bath Temp Mismatch	Bath Temperature Input 1 does not match Bath Temperature Input 2	2s
AL052	Bath Temp Configuration Range Error	Bath High Temp Setpoint is out of range OR Pilot Off Setpoint (if enabled) is greater than or equal to the High Temp Setpoint OR Main Off Setpoint is greater than or equal to the High Temp Setpoint OR Main Off Setpoint is greater than the Pilot Off Setpoint (if enabled) OR Process Setpoint is greater than or equal to the High Temp Setpoint OR Process Setpoint is greater than the Pilot Off Setpoint (if enabled) OR Process Setpoint is greater than the Main Off Setpoint OR Low Temp Setpoint is greater than the Process Setpoint	0
AL053	Bath 1 Sensor Open	Bath Input 1 sensor has an open circuit	6s
AL054	Bath 1 Sensor Short	Bath Input 1 in RTD Mode: Input is measuring a short circuit Bath Input 1 in Thermocouple Mode: This alarm cannot be set	6s
AL055	Bath 1 Out of Range	Bath Input 1 in RTD Mode: Input is outside valid RTD range Bath Input 1 in Thermocouple Mode: Input is outside valid Thermocouple range	6s
AL056	Bath 1 Stale Data	Bath Input 1 is not reading valid data	6s
AL057	Bath 2 Sensor Open	Bath Input 2 sensor has an open circuit	6s
AL058	Bath 2 Sensor Short	Bath Input 2 in RTD Mode: Input is measuring a short circuit Bath Input 2 in Thermocouple Mode: This alarm cannot be set	6s

ID	Name	Alarm Condition	Set
AL059	Bath 2 Out of Range	Bath Input 2 in RTD Mode: Input is outside valid RTD range Bath Input 2 in Thermocouple Mode: Input is outside valid Thermocouple range	6s
AL060	Bath 2 Stale Data	Bath Temperature Input 2 is not reading valid data	6s
AL061	Outlet High Temp ESD	Outlet Temperature Input is greater than High Temp ESD setpoint	2s
AL062	Outlet Temp Configuration Range Error	Outlet High Temp Setpoint is out of range OR Pilot Off Setpoint (if enabled) is greater than or equal to the High Temp Setpoint OR Main Off Setpoint is greater than or equal to the High Temp Setpoint OR Main Off Setpoint is greater than the Pilot Off setpoint (if enabled) OR Process Setpoint is greater than or equal to the High Temp Setpoint OR Process Setpoint is greater than the Pilot Off Setpoint (if enabled) OR Process Setpoint is greater than the Main Off Setpoint OR Low Temp Setpoint is greater than the Process Setpoint	0
AL063	Outlet Sensor Open	Outlet Input sensor has an open circuit	6s
AL064	Outlet Sensor Short	Outlet Input in RTD Mode: Input is measuring a short circuit Outlet Input in Thermocouple Mode: This alarm cannot be set	6s
AL065	Outlet Out of Range	Outlet Input in RTD Mode: Input is outside valid RTD range Outlet Input in Thermocouple Mode: Input is outside valid Thermocouple range	6s
AL066	Outlet Stale Data	Outlet Temperature Input is not reading valid data	6s
AL067	Stack A High Temp ESD	Burner A Stack Temperature Input is greater than High Temp ESD setpoint	2s
AL068	Stack A Temp Configuration Range Error	Burner A Stack High Temp Setpoint is out of range	0
AL069	Stack A Sensor Open	Burner A Stack Input sensor has an open circuit	6s
AL070	Stack A Sensor Short	Burner A Stack Input in RTD Mode: Input is measuring a short circuit Burner A Stack Input in Thermocouple Mode: This alarm cannot be set	6s
AL071	Stack A Out of Range	Burner A Stack Input in RTD Mode: Input is outside valid RTD range Burner A Stack Input in Thermocouple Mode: Input is outside valid Thermocouple range	6s
AL072	Stack A Stale Data	Burner A Stack Input is not reading valid data	6s
AL073	Stack B High Temp ESD	Burner B Stack Temperature Input is greater than High Temp ESD setpoint	2s
AL074	Stack B Temp Configuration Range Error	Burner B Stack High Temp Setpoint is out of range	0
AL075	Stack B Sensor Open	Burner B Stack Input sensor has an open circuit	6s
AL076	Stack B Sensor Short	Burner B Stack Input in RTD Mode: Input is measuring a short circuit Burner B Stack Input in Thermocouple Mode: This alarm cannot be set	6s
AL077	Stack B Out of Range	Burner B Stack Input in RTD Mode: Input is outside valid RTD range Burner B Stack Input in Thermocouple Mode: Input is outside valid Thermocouple range	6s
AL078	Stack B Stale Data	Burner B Stack Input is not reading valid data	6s
AL079	Stack High Temp ESD	Shared Stack Temperature Input is greater than High Temp ESD setpoint	2s
AL080	Stack Temp Configuration Range Error	Shared Stack High Temp Setpoint is out of range	0
AL081	Stack Sensor Open	Shared Stack Input sensor has an open circuit	6s
AL082	Stack Sensor Short	Shared Stack Input in RTD Mode: Input is measuring a short circuit Shared Stack Input in Thermocouple Mode: This alarm cannot be set	6s
AL083	Stack Out of Range	Shared Stack Input in RTD Mode: Input is outside valid RTD range Shared Stack Input in Thermocouple Mode: Input is outside valid Thermocouple range	6s
AL084	Stack Stale Data	Shared Stack Input is not reading valid data	6s
AL085	Aux High Temp ESD	Aux Temp Input is greater than High Temp ESD setpoint	2s
AL086	Aux Temp Out of Range	Aux Temp Input: Less than 3 mA OR greater than 21 mA	1s
AL087	Aux Temp Configuration Range Error	Pilot Off Setpoint (if enabled) is greater than or equal to the High Temp Setpoint OR Main Off Setpoint (if enabled) is greater than or equal to the High Temp Setpoint OR Main Off Setpoint (if enabled) is greater than the Pilot Off setpoint (if enabled) OR Process Setpoint is greater than or equal to the High Temp Setpoint OR Process Setpoint is greater than the Pilot Off Setpoint (if enabled) OR Process Setpoint is greater than the Main Off Setpoint (if enabled) OR Low Temp Setpoint is greater than the Process Setpoint	0
AL088	Ambient Temp Mismatch	Ambient Temperature Measurement mismatch between sensors ^[2]	6s
AL089	Ambient Temp 1 Invalid	Ambient Temperature sensor 1 on BMS card is reporting an invalid reading ^[2]	6s
AL090	Ambient Temp 2 Invalid	Ambient Temperature sensor 2 on BMS card is reporting an invalid reading ^[2]	6s
AL091	No Process Temp	None of Bath, Outlet, or Aux temp are configured to be in Process Control mode	0
AL092	Pilot A Flame Fail	Pilot A has lost flame OR failed to ignite	0
AL093	Pilot B Flame Fail	Pilot B has lost flame OR failed to ignite	0
AL094	Pilot A Flame Detected While Off	Flame has been detected on Pilot A input before Pilot ignition	0
AL095	Pilot B Flame Detected While Off	Flame has been detected on Pilot B input before Pilot ignition	0

ID	Name	Alarm Condition	Set
AL096	Flame A Load Monitor Check Failure	AC voltage on Pilot A input too low to reliably detect flame <i>Note: Usually caused by loading of the flame rod to ground</i>	2s
AL097	Flame B Load Monitor Check Failure	AC voltage on Pilot B input too low to reliably detect flame <i>Note: Usually caused by loading of the flame rod to ground</i>	2s
AL098	Pilot ADC Start Fault	Internal BMS Card fault ^[2]	2s
AL099	Pilot ADC Read Fault	Internal BMS Card fault ^[2]	2s
AL100	Pilot ADC Stop Fault	Internal BMS Card fault ^[2]	2s
AL101	Flame A Voltage Fault	Pilot Flame A flame test failure ^[2]	2s
AL102	Flame B Voltage Fault	Pilot Flame B flame test failure ^[2]	2s
AL103	Low Voltage	In 12V Mode: System Voltage is less than 9.5V In 24V Mode: System Voltage is less than 19.0V	2s
AL104	High Voltage	In 12V Mode: System Voltage is greater than 16.8V In 24V Mode: System Voltage is greater than 33.6V	2s
AL105	System ADC Start Fault	Internal BMS Card fault ^[2]	2s
AL106	System ADC Read Fault	Internal BMS Card fault ^[2]	2s
AL107	System ADC Stop Fault	Internal BMS Card fault ^[2]	2s
AL108	Incomplete Commissioning	The Commissioning Complete setting is set to Incomplete	0
AL109	Cross Compare Failure	Internal BMS Card fault ^[2]	2s
AL110	External Switch Stuck	External switch input is stuck in the Ignite position	4.5s
AL111	External Switch Invalid	External switch input is in an invalid position	0
AL112	User Stop via External Switch	External switch input is in the off position	0
AL113	User Stop via Interface	The BMS card received an appliance stop command from the UI or remote Modbus device	0
AL114	User Stop A via Interface	The BMS card received a Burner A stop command from the UI or remote Modbus device	0
AL115	User Stop B via Interface	The BMS card received a Burner B stop command from the UI or remote Modbus device	0
AL116	Settings CRC Failed	Settings have been corrupted and cannot be verified	0
AL117	State Mismatch	Internal BMS Card fault ^[2]	1s
AL118	Pressure I2C Bus Fault	Internal BMS Card fault ^[2]	2s
AL119	Pressure A I2C Bus Fault	Internal BMS Card fault ^[2]	2s
AL120	Pressure B I2C Bus Fault	Internal BMS Card fault ^[2]	2s
AL121	Level/Flow I2C Bus Fault	Internal BMS Card fault ^[2]	2s
AL122	Aux Temp I2C Bus Fault	Internal BMS Card fault ^[2]	2s
AL123	Aux In 1 I2C Bus Fault	Internal BMS Card fault ^[2]	2s
AL124	Aux In 2 I2C Bus Fault	Internal BMS Card fault ^[2]	2s
AL125	Pilot 1 I2C Bus Fault	Internal BMS Card fault ^[2]	2s
AL126	Pilot 2 I2C Bus Fault	Internal BMS Card fault ^[2]	2s
AL127	SSV1 I2C Bus Fault	Internal BMS Card fault ^[2]	2s
AL128	SSV2 I2C Bus Fault	Internal BMS Card fault ^[2]	2s
AL129	SSV UP I2C Bus Fault	Internal BMS Card fault ^[2]	2s
AL130	System Voltage Current I2C Bus Fault	Internal BMS Card fault ^[2]	2s
AL131	IO Short Switch Run Fault	Internal BMS Card fault ^[2]	1.5s
AL132	IO Short Switch Ignition Fault	Internal BMS Card fault ^[2]	1.5s
AL133	IO Short Start Fault	Internal BMS Card fault ^[2]	1.5s
AL134	IO Short Proof of Closure A Fault	Internal BMS Card fault ^[2]	1.5s
AL135	IO Short Terminal 52 Fault	Internal BMS Card fault ^[2]	1.5s
AL136	IO Short Proof of Closure B Fault	Internal BMS Card fault ^[2]	1.5s
AL137	IO Short ESD Fault	Internal BMS Card fault ^[2]	1.5s
AL138	Analog Output 1 Fault	Aux Output wiring problem or board fault	2s
AL139	Analog Output 2 Fault	TCV B Output wiring problem or board fault	2s
AL140	Analog Output 3 Fault	TCV A Output wiring problem or board fault	2s
AL141	Flash Failed To Read	Internal BMS Card fault ^[2]	0
AL142	Flash Failed To Write	Internal BMS Card fault ^[2]	0
AL143	Descriptor Failure	Internal BMS Card fault ^[2]	0
AL144	Descriptor Mismatch	Internal BMS Card fault ^[2]	0
AL145	Pilot A Output Voltage Fault	Pilot A output is de-energized and voltage at BMS terminal 15 is greater than 5V	10s
AL146	Pilot B Output Voltage Fault	Pilot B output is de-energized and voltage at BMS terminal 17 is greater than 5V	10s

ID	Name	Alarm Condition	Set
AL147	SSVA Output Voltage Fault	SSV A output is de-energized and voltage at BMS terminal 19 is greater than 5V	10s
AL148	SSVB Output Voltage Fault	SSV B output is de-energized and voltage at BMS terminal 21 is greater than 5V	10s
AL149	SSV UP Output Voltage Fault	SSV UP output is de-energized and voltage at BMS terminal 23 is greater than 5V	10s
AL150	Start Contact Out of Range	Input is not within a valid range ^[1]	2s
AL151	Upstream Proof of Closure Contact Out of Range	Input is not within a valid range ^[1]	2s
AL152	ESD Contact Out of Range	Input is not within a valid range ^[1]	2s
AL153	Proof of Closure A Contact Out of Range	Input is not within a valid range ^[1]	2s
AL154	Proof of Closure B Contact Out of Range	Input is not within a valid range ^[1]	2s
AL155	Terminal 52 Contact Out of Range	Internal BMS Card fault ^[2]	2s
AL156	Digital Input ADC Start Fault	Internal BMS Card fault ^[2]	2s
AL157	Digital Input ADC Read Fault	Internal BMS Card fault ^[2]	2s
AL158	Digital Input ADC Stop Fault	Internal BMS Card fault ^[2]	2s
AL159	Safety Output Mismatch	Internal BMS Card fault ^[2]	2s
AL160	Processor Reset	Internal BMS Card fault ^[2]	0
AL161	Calibration CRC Failed	Internal BMS Card fault ^[2]	0
AL162	Brownout Reset Voltage Incorrect	Internal BMS Card fault ^[2]	0
AL163	Flame 1 DC Input Open	Internal BMS Card fault ^[2]	2s
AL164	Flame 2 DC Input Open	Internal BMS Card fault ^[2]	2s
AL165	Factory Calibration Error	Internal BMS Card fault ^[2]	0
AL166	Minimum Burners Running Violated	Minimum Burners Running setting is set to 2 AND only one burner is running	0.5s
AL167	Reserved		
AL168	Shutdown Failed To Set	Internal BMS Card fault ^[2]	0
AL169	Process Setpoint Adjust Unit Configuration Error	Process Setpoint Adjust Input units are not set to a valid temperature unit	0
AL170	Firing Rate Configuration Error	Aux Input 1 or 2 is configured as an External Firing Rate input AND Process Control Mode is not set to Firing Rate	0
AL171	System Voltage Mismatch	Internal BMS Card fault ^[2]	10s

^[1] This fault can occur in one of two scenarios: a negative voltage is present on the Signal In terminal OR the BMS card has been compromised

^[2] This fault usually occurs when the BMS card has been compromised

10.2 WAITS

ID	Name	Wait Condition	Set
WT001	Low Voltage	In 12V Mode: Voltage Restart is enabled AND System Voltage is less than 9.5V In 24V Mode: Voltage Restart is enabled AND System Voltage is less than 19.0V	2s
WT002	High Voltage	In 12V Mode: Voltage Restart is enabled AND System Voltage is greater than 16.8V In 24V Mode: Voltage Restart is enabled AND System Voltage is greater than 33.6V	2s
WT003	Low Upstream Pressure ¹	Upstream Pressure Input in 4-20 mode: Input is less than Low Trip setting Upstream Pressure Input in Digital low-pressure mode: Input is open Upstream Pressure Input in Digital high-pressure mode: This wait cannot be set	Upstream Pressure Delay setting
WT004	Low Pressure A ¹	Burner A Pressure Input in 4-20 mode: Input is less than Low Trip setting Burner A Pressure Input in Digital mode: This wait cannot be set	Upstream Pressure Delay setting
WT005	Low Pressure B ¹	Burner B Pressure Input in 4-20 mode: Input is less than Low Trip setting Burner B Pressure Input in Digital mode: This wait cannot be set	Upstream Pressure Delay setting
WT006	Low Level/Flow ¹	Level Input in 4-20 mode: Input is less than Level Low Trip setting Level Input in Digital mode: Input is open	Level/Flow Delay setting
WT007	High Level/Flow ¹	Level input in 4-20 mode: Input is greater than Level High Trip Level input in Digital mode: This wait cannot be set	Level/Flow Delay setting
WT008	High Bath Temp	Bath temperature is too high to require the system to be in a fuel state.	2s
WT009	High Outlet Temp	Outlet temperature is too high to require the system to be in a fuel state.	2s
WT010	High Aux Temp	Aux Temp temperature is too high to require the system to be in a fuel state.	2s
WT011	Start Contact Open	Start contact open	1s
WT012	Purging A	Burner A is Purging	N/A
WT013	Purging B	Burner B is Purging	N/A
WT014	Aux In 1 Contact Open A	Aux In 1 input in 4-20 mode: This wait cannot be set Aux In 1 input as Burner A wait in Digital mode: Input is open	2s
WT015	Aux In 1 Low Trip A	Aux In 1 Input as Burner A wait in 4-20 mode: Input is less than Low Trip setting Aux In 1 Input in Digital mode: This wait cannot be set	2s
WT016	Aux In 1 High Trip A	Aux In 1 Input as Burner A wait in 4-20 mode: Input is greater than High Trip setting Aux In 1 Input in Digital mode: This wait cannot be set	2s
WT017	Aux In 1 Contact Open B	Aux In 1 input in 4-20 mode: This wait cannot be set Aux In 1 input as Burner B wait in Digital mode: Input is open	2s
WT018	Aux In 1 Low Trip B	Aux In 1 Input as Burner B wait in 4-20 mode: Input is less than Low Trip setting Aux In 1 Input in Digital mode: This wait cannot be set	2s
WT019	Aux In 1 High Trip B	Aux In 1 Input as Burner B wait in 4-20 mode: Input is greater than High Trip setting Aux In 1 Input in Digital mode: This wait cannot be set	2s
WT020	Aux In 1 Contact Open	Aux In 1 input in 4-20 mode: This wait cannot be set Aux In 1 input as shared appliance wait in Digital mode: Input is open	2s
WT021	Aux In 1 Low Trip	Aux In 1 Input as shared appliance wait in 4-20 mode: Input is less than Low Trip setting Aux In 1 Input in Digital mode: This wait cannot be set	2s
WT022	Aux In 1 High Trip	Aux In 1 Input as shared appliance wait in 4-20 mode: Input is greater than High Trip setting Aux In 1 Input in Digital mode: This wait cannot be set	2s
WT023	Aux In 2 Contact Open A	Aux In 2 input in 4-20 mode: This wait cannot be set Aux In 2 input as Burner A wait in Digital mode: Input is open	2s
WT024	Aux In 2 Low Trip A	Aux In 2 Input as Burner A wait in 4-20 mode: Input is less than Low Trip setting Aux In 2 Input in Digital mode: This wait cannot be set	2s
WT025	Aux In 2 High Trip A	Aux In 2 Input as Burner A wait in 4-20 mode: Input is greater than High Trip setting Aux In 2 Input in Digital mode: This wait cannot be set	2s
WT026	Aux In 2 Contact Open B	Aux In 2 input in 4-20 mode: This wait cannot be set Aux In 2 input as Burner B wait in Digital mode: Input is open	2s
WT027	Aux In 2 Low Trip B	Aux In 2 Input as Burner B wait in 4-20 mode: Input is less than Low Trip setting Aux In 2 Input in Digital mode: This wait cannot be set	2s
WT028	Aux In 2 High Trip B	Aux In 2 Input as Burner B wait in 4-20 mode: Input is greater than High Trip setting Aux In 2 Input in Digital mode: This wait cannot be set	2s
WT029	Aux In 2 Contact Open	Aux In 2 input in 4-20 mode: This wait cannot be set Aux In 2 input as shared appliance wait in Digital mode: Input is open	2s
WT030	Aux In 2 Low Trip	Aux In 2 Input as shared appliance wait in 4-20 mode: Input is less than Low Trip setting Aux In 2 Input in Digital mode: This wait cannot be set	2s
WT031	Aux In 2 High Trip	Aux In 2 Input as shared appliance wait in 4-20 mode: Input is greater than High Trip setting Aux In 2 Input in Digital mode: This wait cannot be set	2s
WT034	Waiting for Burner A Ignition	Burner B is in the Waiting state and Burner A is in the Ignition state	0
WT035	Waiting for Burner B Ignition	Burner A is in the Waiting state and Burner B is in the Ignition state	0
WT036	Waiting for Burner A	Minimum Burners Running is set to 2 AND Valve Sync is enabled AND Wait present on Burner A	0
WT037	Waiting for Burner B	Minimum Burners Running is set to 2 AND Valve Sync is enabled AND Wait present on Burner B	0

¹ Associated Trip Mode setting must be configured as a Wait

10.3 WARNINGS

ID	Name	Warning Condition	Set
WN001	Low Voltage	In 12V Mode: System Voltage is less than 10.2V In 24V Mode: System Voltage is less than 20.4V	2s
WN002	High Voltage	In 12V Mode: System Voltage is greater than 16.2V In 24V Mode: System Voltage is greater than 32.4V	2s
WN003	Low Level/Flow ¹	Level Input in 4-20 mode: Input is less than Level Low Trip setting Level Input in Digital mode: Input is open	Level/Flow Delay setting
WN004	High Level/Flow ¹	Level input in 4-20 mode: Input is greater than Level High Trip Level input in Digital mode: This warning cannot be set	Level/Flow Delay setting
WN005	Low Bath Temp	Bath Temperature reading is at or below the Bath Low Temp Setpoint	2s
WN006	Low Outlet Temp	Outlet Temperature reading is at or below the Outlet Low Temp Setpoint	2s
WN007	Low Aux Temp	Aux Temp Input reading is at or below the Aux Temp Low Temp Setpoint	2s
WN008	Low Upstream Pressure ¹	Upstream Pressure Input in 4-20 mode: Input is less than Low Trip setting Upstream Pressure Input in Digital low-pressure mode: Input is open Upstream Pressure Input in Digital high-pressure mode: This warning cannot be set	Upstream Pressure Delay setting
WN009	Low Pressure A ¹	Pressure A Input in 4-20 mode: Input is less than Low Trip setting Pressure A Input in Digital mode: This warning cannot be set	Pressure A Delay Setting
WN010	Low Pressure B ¹	Pressure B Input in 4-20 mode: Input is less than Low Trip setting Pressure B Input in Digital mode: This warning cannot be set	Pressure A Delay Setting
WN011	High Upstream Pressure	Pressure in 4-20 mode: Input is greater than High Trip setpoint AND SSV UP outputs de-energized Pressure in Digital mode: Input is open AND SSV UP output is de-energized	2s
WN012	High Pressure A	Pressure A in 4-20 mode: Input is greater than High Trip setpoint AND SSV A output de-energized Pressure A in Digital mode: Input is open AND SSV A output de-energized	2s
WN013	High Pressure B	Pressure B in 4-20 mode: Input is greater than High Trip setpoint AND SSV B output de-energized Pressure B in Digital mode: Input is open AND SSV B output de-energized	2s
WN014	Aux In 1 Contact Open A	Aux In 1 input in 4-20 mode: This warning cannot be set Aux In 1 input as Burner A warning in Digital mode: Input is open	2s
WN015	Aux In 1 Low Trip A	Aux In 1 Input as Burner A warning in 4-20 mode: Input is less than Low Trip setting Aux In 1 Input in Digital mode: This warning cannot be set	2s
WN016	Aux In 1 High Trip A	Aux In 1 Input as Burner A warning in 4-20 mode: Input is greater than High Trip setting Aux In 1 Input in Digital mode: This warning cannot be set	2s
WN017	Aux In 1 Contact Open B	Aux In 1 input in 4-20 mode: This warning cannot be set Aux In 1 input as Burner B warning in Digital mode: Input is open	2s
WN018	Aux In 1 Low Trip B	Aux In 1 Input as Burner B warning in 4-20 mode: Input is less than Low Trip setting Aux In 1 Input in Digital mode: This warning cannot be set	2s
WN019	Aux In 1 High Trip B	Aux In 1 Input as Burner B warning in 4-20 mode: Input is greater than High Trip setting Aux In 1 Input in Digital mode: This warning cannot be set	2s
WN020	Aux In 1 Contact Open	Aux In 1 input in 4-20 mode: This warning cannot be set Aux In 1 input as shared appliance warning in Digital mode: Input is open	2s
WN021	Aux In 1 Low Trip	Aux In 1 Input as shared appliance warning in 4-20 mode: Input is less than Low Trip setting Aux In 1 Input in Digital mode: This warning cannot be set	2s
WN022	Aux In 1 High Trip	Aux In 1 Input as shared appliance warning in 4-20 mode: Input is greater than High Trip setting Aux In 1 Input in Digital mode: This warning cannot be set	2s
WN023	Aux In 2 Contact Open A	Aux In 2 input in 4-20 mode: This warning cannot be set Aux In 2 input as Burner A warning in Digital mode: Input is open	2s
WN024	Aux In 2 Low Trip A	Aux In 2 Input as Burner A warning in 4-20 mode: Input is less than Low Trip setting Aux In 2 Input in Digital mode: This warning cannot be set	2s
WN025	Aux In 2 High Trip A	Aux In 2 Input as Burner A warning in 4-20 mode: Input is greater than High Trip setting Aux In 2 Input in Digital mode: This warning cannot be set	2s
WN026	Aux In 2 Contact Open B	Aux In 2 input in 4-20 mode: This warning cannot be set Aux In 2 input as Burner B warning in Digital mode: Input is open	2s
WN027	Aux In 2 Low Trip B	Aux In 2 Input as Burner B warning in 4-20 mode: Input is less than Low Trip setting Aux In 2 Input in Digital mode: This warning cannot be set	2s
WN028	Aux In 2 High Trip B	Aux In 2 Input as Burner B warning in 4-20 mode: Input is greater than High Trip setting Aux In 2 Input in Digital mode: This warning cannot be set	2s
WN029	Aux In 2 Contact Open	Aux In 2 input in 4-20 mode: This warning cannot be set Aux In 2 input as shared appliance warning in Digital mode: Input is open	2s
WN030	Aux In 2 Low Trip	Aux In 2 Input as shared appliance warning in 4-20 mode: Input is less than Low Trip setting Aux In 2 Input in Digital mode: This warning cannot be set	2s
WN031	Aux In 2 High Trip	Aux In 2 Input as shared appliance warning in 4-20 mode: Input is greater than High Trip setting Aux In 2 Input in Digital mode: This warning cannot be set	2s

ID	Name	Warning Condition	Set
WN032	Upstream Proof of Closure Contact Failed to Open	POC UP Input enabled: Input closed AND SSV UP output energized	10s
WN033	Proof of Closure A Contact Failed to Open	POC A Input enabled: Input closed AND SSV A output energized	10s
WN034	Proof of Closure B Contact Failed to Open	POC B Input enabled: Input closed AND SSV B output energized	10s
WN035	PID Configuration Error	Process Control Mode is set to PID control with a temperature input that is not set to process control	2s
WN036	UI to BMS Firmware Mismatch	UI and BMS firmware versions do not match	0
WN037	Communication Loss	UI card has lost communications with the BMS card	0
WN038	Hardware Descriptor Error	Internal BMS Card fault	0
WN039	Product Variant Descriptor Error	Internal BMS Card fault	0
WN040	Firmware Descriptor Error	Internal BMS Card fault	0
WN041	Bootloader Descriptor Error	Internal BMS Card fault	0
WN042	UI Descriptor Error	Internal UI Card fault	0

¹ Associated Trip Mode setting must be configured as a Warning

10.4 MAIN PERMISSIVES

ID	Name	Main Permissive Condition	Set
MP001	Low Upstream Pressure ¹	Upstream Pressure Input in 4-20 mode: Input is less than Low Trip setting Upstream Pressure Input in Digital low-pressure mode: Input is open Upstream Pressure Input in Digital high-pressure mode: This main permissive cannot be set	Low Pressure Delay setting
MP002	Low Pressure A ¹	Pressure A Input in 4-20 mode: Input is less than Low Trip setting Pressure A Input in Digital mode: This main permissive cannot be set	Low Pressure Delay setting
MP003	Low Pressure B ¹	Pressure B Input in 4-20 mode: Input is less than Low Trip setting Pressure B Input in Digital mode: This main permissive cannot be set	Low Pressure Delay setting
MP004	Aux In 1 Contact Open A	Aux In 1 input in 4-20 mode: This main permissive cannot be set Aux In 1 input as Burner A main permissive in Digital mode: Input is open	2s
MP005	Aux In 1 Low Trip A	Aux In 1 Input as Burner A main permissive in 4-20 mode: Input is less than Low Trip setting Aux In 1 Input in Digital mode: This main permissive cannot be set	2s
MP006	Aux In 1 High Trip A	Aux In 1 Input as Burner A main permissive in 4-20 mode: Input is greater than High Trip setting Aux In 1 Input in Digital mode: This main permissive cannot be set	2s
MP007	Aux In 1 Contact Open B	Aux In 1 input in 4-20 mode: This main permissive cannot be set Aux In 1 input as Burner B main permissive in Digital mode: Input is open	2s
MP008	Aux In 1 Low Trip B	Aux In 1 Input as Burner B main permissive in 4-20 mode: Input is less than Low Trip setting Aux In 1 Input in Digital mode: This main permissive cannot be set	2s
MP009	Aux In 1 High Trip B	Aux In 1 Input as Burner B main permissive in 4-20 mode: Input is greater than High Trip setting Aux In 1 Input in Digital mode: This main permissive cannot be set	2s
MP010	Aux In 1 Contact Open	Aux In 1 input in 4-20 mode: This main permissive cannot be set Aux In 1 input as shared appliance main permissive in Digital mode: Input is open	2s
MP011	Aux In 1 Low Trip	Aux In 1 Input as shared appliance main permissive in 4-20 mode: Input is less than Low Trip setting Aux In 1 Input in Digital mode: This main permissive cannot be set	2s
MP012	Aux In 1 High Trip	Aux In 1 Input as shared appliance main permissive in 4-20 mode: Input is greater than High Trip setting Aux In 1 Input in Digital mode: This main permissive cannot be set	2s
MP013	Aux In 2 Contact Open A	Aux In 2 input in 4-20 mode: This main permissive cannot be set Aux In 2 input as Burner A main permissive in Digital mode: Input is open	2s
MP014	Aux In 2 Low Trip A	Aux In 2 Input as Burner A main permissive in 4-20 mode: Input is less than Low Trip setting Aux In 2 Input in Digital mode: This main permissive cannot be set	2s
MP015	Aux In 2 High Trip A	Aux In 2 Input as Burner A main permissive in 4-20 mode: Input is greater than High Trip setting Aux In 2 Input in Digital mode: This main permissive cannot be set	2s
MP016	Aux In 2 Contact Open B	Aux In 2 input in 4-20 mode: This main permissive cannot be set Aux In 2 input as Burner B main permissive in Digital mode: Input is open	2s
MP017	Aux In 2 Low Trip B	Aux In 2 Input as Burner B main permissive in 4-20 mode: Input is less than Low Trip setting Aux In 2 Input in Digital mode: This main permissive cannot be set	2s
MP018	Aux In 2 High Trip B	Aux In 2 Input as Burner B main permissive in 4-20 mode: Input is greater than High Trip setting Aux In 2 Input in Digital mode: This main permissive cannot be set	2s
MP019	Aux In 2 Contact Open	Aux In 2 input in 4-20 mode: This main permissive cannot be set Aux In 2 input as shared appliance main permissive in Digital mode: Input is open	2s
MP020	Aux In 2 Low Trip	Aux In 2 Input as shared appliance main permissive in 4-20 mode: Input is less than Low Trip setting Aux In 2 Input in Digital mode: This main permissive cannot be set	2s
MP021	Aux In 2 High Trip	Aux In 2 Input as shared appliance main permissive in 4-20 mode: Input is greater than High Trip setting Aux In 2 Input in Digital mode: This main permissive cannot be set	2s
MP022	Reserved		
MP023	Reserved		
MP024	Waiting for Burner A	Minimum Burners Running is set to 2 AND Valve Sync is enabled AND Main Permissive present on Burner A	0
MP025	Waiting for Burner B	Minimum Burners Running is set to 2 AND Valve Sync is enabled AND Main Permissive present on Burner B	0

¹ Associated Trip Mode setting must be configured as a Main Permissive

11 GLOSSARY

Alarm	An indication of an abnormal condition in either the equipment or the process.	Non-volatile Lockout	Condition such that a restart can only be accomplished by a manual reset of the system and by no other cause
Continuous Pilot	A pilot which, once placed in operation, is intended to remain ignited continuously until it is manually interrupted	Permanent Operation	System which is intended to remain in the running position for longer than 24 h without interruption
Digital Input	An input to the system that can be one of only two states (Energized or De-energized).	Pilot-flame Establishing Period	Period of time between the signal to energize the pilot fuel flow means and the signal indicating presence of the pilot flame
Electronic Disconnection	Non-cycling interruption by an electronic device of a circuit for functional disconnection which provides a disconnection other than by means of an air gap by satisfying certain electrical requirements in at least one pole	Post-Ignition Time	Period of time between the signal indicating presence of flame and the signal to de-energize the ignition device
Flame Detector	Device which provides the programming unit with a signal indicating the presence of absence of flame	Post-Purge Time	Purge time that takes place immediately following the shutting off of the fuel supply
Flame Detector Response Time	Period of time between loss of the sensed flame and the signal indicating the absence of flame	Pre-Ignition Time	Period of the ignition time between the signal to ignite and the signal to energize the fuel flow means
Flame Detector Self-Checking Rate	Frequency of self-checking function of the flame detector (in number of operations per unit of time)	Pre-Purge Time	Purge time that takes place between initiation of a burner control sequence and the admission of fuel to the burner
Flame Failure Lock-out Time	Period of time between the signal indicating absence of flame and lock-out	Recycle Time	Period of time between the signal to de-energize the fuel flow means following the loss of flame and the signal to begin a new start-up procedure
Full Rate Start	Condition in which the main burner ignition and subsequent flame supervision occur at full fuel rate	Safety Output	A powered electrical output from the PF2200 BMS card designed to control safety actuators (e.g. safety shut off valves, ignition coils, etc.). Safety Outputs of the PF2200 BMS card are as follows: Pilot 1, Pilot 2, SSV, High Fire, Coil 1, and Coil 2.
Ignition Time	Period of time during which the ignition device is energized	Safety-interlock	A term used to describe an input (either switch or Transmitter) that must be satisfied to run. If the interlock is not satisfied (e.g. open switch or out of range transmitter) the system will proceed to lock-out.
Incorporated Control	Control intended for incorporation in, or on, an equipment, but which can be tested separately.	Shutdown	The process the system goes through when it receives an alarm event while running. This is immediately followed by entering the state of Lockout.
Intermittent Pilot	A pilot which is automatically ignited when an appliance is called on to operate and which remains continuously ignited during each period of main burner operation. The pilot is automatically extinguished when each main burner operating cycle is completed	Signal for Absence of Flame	Maximum signal which indicates the loss of flame
Interrupted Ignition	A type of ignition which is energized prior to the admission of fuel to the main burner and which is de-energized when the main flame is established	Signal for Presence of Flame	Minimum signal which indicates the presence of flame when there was previously no flame
Interrupted Pilot	A pilot which is automatically ignited prior to the admission of fuel to the main burner and which is automatically extinguished when the main flame is established	Start-up Lock-out Time	Period of time between the signal to energize the fuel flow means and lock-out
Lockout	A state in which all powered outputs (Valves and Ignition) are de-energized and interaction from the user is required in order to exit the state.	Type 2 Action	Automatic action for which the manufacturing deviation and the drift of its operating value, operating time, or operating sequence have been declared and tested per IEC 60730
Low Rate Start	Condition in which main burner ignition occurs at low fuel rate. Once ignition at low fuel rate occurs and the flame is proven, full main burner fuel rate may be admitted	Wait	An event which causes the BMS to proceed to a state which will de-energize all safety outputs. When all wait events clear, the BMS is free to automatically recycle.
Main Permissive	An event which causes the BMS to de-energize the main solenoid outputs (SSV) and remain in that state until the event clears (or an alarm / wait condition forces the BMS out)	Waiting Time	Period between the start signal and the signal to energize the ignition device. For burners without fans, natural ventilation of the combustion chamber and the flue passages normally takes place during this time.
Maximum Flame-failure Reignition Time	Period of time between the signal indicating absence of flame and the signal to energize the ignition device. During this time period the fuel supply is not shut off.		

12 ACRONYMS

1oo1	One out of One deployment	PWM	Pulse Width Modulation
BMS	Burner Management System	RTD	Resistive Thermal Device
ESD	Emergency Shut Down – a mechanism that shuts down the system in the event of a safety emergency	SIL	Safety Integrity Level. A discrete level (one out of a possible four) for specifying the safety integrity requirements of the safety functions to be allocated to the E/E/PE safety-related systems where Safety Integrity Level 4 has the highest level of safety integrity, and Safety Integrity Level 1 has the lowest
HEI	High Energy Ignition	SIF	Safety Instrumented Function. A set of equipment intended to reduce the risk due to a specific hazard (a safety loop)
HFT	Hardware Fault Tolerance	SFF	Safe Failure Fraction. The fraction of the overall failure rate of a device that results in either a safe fault or a diagnosed unsafe fault
HFV	High Fire Valve	SSV	Safety shutoff valve.
I/O	The generic name for a terminal that can be an input, output, or a combination of both.	TCV	Temperature Control Valve
PF2200-DB	The model number for the PF2200 Dual Burner BMS product. Consists of: BMS Card, User Interface Card, keypad, and enclosure.		
PoC	Proof of Closure		
PFN	Profire Network. Method of communication between User Interface Card and BMS Card.		

13 DOCUMENT REVISION HISTORY

Document Version	Release Date	Applicable BMS Hardware	Applicable UI Hardware	Applicable Firmware
v3.0	25 OCT 2021	v2.3.x	v3.2.x	DB 1.1.0
v2.0	20 SEP 2021	v2.3.x	v3.2.x	DB 1.1.0
v1.0	05 MAR 2021	v2.3.x	v3.2.x	DB 1.0.3

13.1 CHANGE SUMMARY

13.1.1 VERSION 3.0

- Added French safety warnings.

13.1.2 VERSION 2.0

- Added UL certification information on p.4
- Updated Auxiliary Input Deadband setting limits on p.75



UNITED STATES

1.801.796.5127
321 South, 1250 West Suite 1
Lindon, UT 84042, USA
support@profireenergy.com

CANADA

1.780.960.5278
9671 - 283 Street
Acheson, AB T7X 6J5, Canada
support@profireenergy.com