



***PF2100 USER MANUAL***

*For Firmware E1.8.217 Rev. 1.0*

# TABLE OF CONTENTS

PF2100 MANUAL *For Firmware E1.8.217 Rev. 1.0*

## 1 INTRODUCTION

- 1.1 Important Safety Information
- 1.2 HW & FW Versioning
- 1.3 Approvals
- 1.4 Available Models
- 1.5 Included Components
- 1.6 Common Applications & Optional Hardware
- 1.7 System Diagram
- 1.8 Terminal Card Descriptions

## 2 INSTALLATION

- 2.1 Installation Warnings
- 2.2 Mounting Considerations
- 2.3 Terminal Card Diagram
- 2.4 Wiring

## 3 USER INTERFACE & SETTINGS

- 3.1 User Interface
- 3.2 Menu Navigation
- 3.3 Menu Map
- 3.4 Initial System Settings
- 3.5 Optional Settings
- 3.6 System Operation

## 4 SYSTEM BEHAVIOR

- 4.1 System Behavior
- 4.2 Process Control
- 4.3 Contact Behavior

## 5 EXPANSION CARDS

- 5.1 4-20mA Expansion Card
- 5.2 Modbus Expansion Card

## 6 TROUBLESHOOTING

- 6.1 Common Issues & Solutions
- 6.2 Shutdown Messages
- 6.3 Alarm Codes
- 6.4 Warning Messages
- 6.5 Flame Detection Troubleshooting Guide
- 6.6 Thermocouple Troubleshooting Guide

## APPENDICES

- A PID Tuning Procedure
- B Field Calibration
- C Resetting to Defaults

# 1 | INTRODUCTION

The PF2100 BMS (Burner Management System) is an electronic control and monitoring system designed for use on a wide array of natural draft burner industrial applications. It provides electronic pilot ignition, flame detection, temperature control, and remote monitoring. In addition to being an extremely useful tool, it improves safety by preventing the flame from being lit under unsafe conditions.

## 1.1 | Important Safety Information

Installation and use must conform to the directions in this manual.

System must be properly connected to earth-ground for effective operation of flame detection circuitry.

Electrical devices connected to the controller must meet certain electrical standards and be within voltage limits.

Replacement fuses must be ceramic and of correct rating.

Avoid unauthorized replacement of the fuse.

### WARNINGS

This equipment is suitable for use in class 1, division 2, groups abcd or non-hazardous locations only.

Do not service unless area is known to be non-hazardous.

Do not open when energized.

### EXPLOSION HAZARD

Do not disconnect while circuit is live unless area is known to be non-hazardous or equivalent.

Substitution of components may impair suitability for class 1, division 2.

### FOR ANY QUESTIONS PLEASE VISIT OR CALL US.

[www.profireenergy.com](http://www.profireenergy.com) | 1.855.PRO.FIRE

## 1.2 | HW & FW Versioning

This version of the manual was written for use with PF2100 systems that have the following hardware and firmware versions.

ITEM	HW VERSION	FW VERSION
Door Card	v1.71	E1.8.217
Terminal Card	v2.4.2	E1.8.217
4-20mA Card	v3.0	v4.1
Modbus Card	v2.0	v4.4
4-20mA Repeater Card	v1.2	v4.1
Data Logging Card	v2.4	v5.1

System hardware and firmware versions can be found printed on separate labels inside of the enclosure on each circuit board.

## 1.3 | Approvals

CSA C22.2 No. 199, 3rd Edition  
ANSI Z21.20, 15th Edition  
UL 372, 6th Edition

Class I, Zone 2,  
AEx, nA IIC, T4, IP66  
Ex nA IIC T4 IP66



CSA C22.2 No. 0-M91  
CSA C22.2 No. 0.4-04  
CSA C22.2 No. 94-91  
CSA C22.2 No. 213-M1987  
CSA E60079-0:2007  
CSA C22.2 No. 60079-15:12  
ANSI-ISA-12.12.01-2007  
UL No. 60079-0, Ed. 6  
UL No. 60079-15, Ed. 4

## 1.4 | Available Models

The PF2100 is available in two configurations: Base Model and Internal Coil Model.

The Base Model is for use with externally mounted ignition coils. This is useful when the controller must be mounted more than 5m (15ft) away from the burner. An external ignition coil can be purchased separately from Profire for use with this model.

The Internal Coil Model includes a built-in ignition coil and can be used whenever the controller can be mounted less than 5m (15ft) away from the burner.

Optional expansion cards are also available:

- 4-20mA Repeater Expansion Card (1PS166)
- (PFP- 210BGY) Modbus Expansion Card
- (PFP-210BHZ) Data Logging Expansion Card (210BKZ)

## BASE MODELS

MODEL #	MODEL DESCRIPTION
E0000	Base Model
E0400*	Base Model with 4-20mA Repeater Expansion Card
E0R00	Base Model with 4-20mA Repeater Expansion Card
E0M00	Base Model with ModBus Expansion Card
E04M0*	Base Model with 4-20mA Repeater Expansion Card and Modbus Expansion Card
E04M0	Base Model with 4-20mA Repeater Expansion Card and Modbus Expansion Card

## INTERNAL COIL MODELS

MODEL #	MODEL DESCRIPTION
EC000	Internal Coil Model
EC400*	Internal Coil Model with 4-20mA Repeater Expansion Card
ECR00	Internal Coil Model with 4-20mA Repeater Expansion Card
ECM00	Internal Coil Model with Modbus Expansion Card
EC4M0*	Internal Coil Model with 4-20mA Repeater Expansion Card and Modbus Expansion Card
ECRM0	Internal Coil Model with 4-20mA Repeater Expansion Card and Modbus Expansion Card

\*Discontinued model

## 1.5 | Included Components

CODE	DESCRIPTION	E0000	E0400	E0M00	E04M0	EC000	EC400	ECM00	EC4M0
A	PF2100	•	•	•	•	•	•	•	•
B	Mounting Brackets & Screws	•	•	•	•	•	•	•	•
C	Installation Guide	•	•	•	•	•	•	•	•
D	Internal Coil					•	•	•	•
E	Ferrules (2)					•	•	•	•
F	Straight Silicone Boots (2)					•	•	•	•
G	Ignition Cable (20ft)					•	•	•	•
H	4-20mA Repeater Expansion Card		•		•		•		•
I	Modbus Expansion Card			•	•			•	•

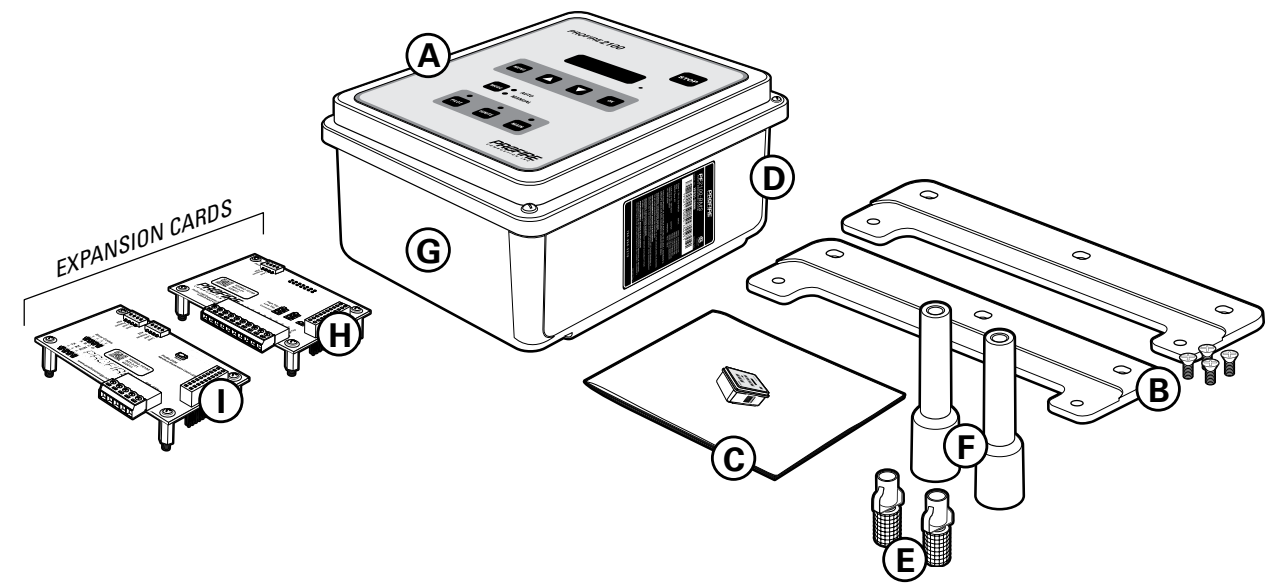

## GENERAL FEATURES

- Designed for use with natural draft fire tube heaters
- Meets or exceeds all relevant codes and standards
- Easy installation with clearly marked component I/O
- Easily accessible removable terminal connections
- Rapid 3 second shut-down on flame-out
- Electronic spark ignition
- Low-power operating mode to accommodate solar panel or TEG applications
- Auto-relight or manual operation
- Transient protected and fail-safe circuits
- All solid state circuit components
- CSA compliant for Class I, Division 2 locations
- Certified for use on B.149 compliant valve trains
- Optional internal or external ignition coil

## INPUTS & OUTPUTS

- Digital inputs for safety interlock device connections (6)
- Digital outputs (5)
- 4-20mA output (1)
- Flame-rod input (1)
- Thermocouple inputs (3)

## TECHNICAL SPECIFICATIONS

TEMPERATURE RATINGS	MIN	MAX
Operating Range	-40°C (-40°F)	+55°C (+130°F)
Storage Range	-40°C (-40°F)	+80°C (176°F)

<b>POWER CONSUMPTION</b>	<b>12V</b>	<b>24V</b>
Controller only, display ON	2.6W	2.9W
Controller only, display OFF	1.1W	1.2W
Maximum Total Current Draw	5A	5A
Maximum Valve Current Draw	2A	2A
Ignition Voltage (Internal Coil)	up to 20 kV	up to 40 kV

<b>TERMINAL BLOCKS</b>	<b>VALUE</b>
Maximum Wire Gauge	12 AWG

<b>STATUS CONTACT</b>	<b>VALUE</b>
Type	Dry
MAX Voltage	40VDC
MAX Continuous Current	250mA
Impedance (When Closed)	15Ω

<b>PHYSICAL DIMENSIONS</b>	<b>VALUE</b>
Width	30.9 cm (12.15 in)
Height	23.4 cm (9.23 in)
Depth	13.4 cm (5.28 in)

<b>WEIGHT</b>	<b>VALUE</b>
E0000 Model	4.0lbs / 1.8kg
E0400 Model	4.5lbs / 2.0kg
E0M00 Model	4.5lbs / 2.0kg
EC000 Model	6.0lbs / 2.6kg
E0R00 Model	4.5lbs / 2.0kg

<b>FUSES</b>	<b>VALUE</b>
Main Fuse Rating	5A / 250 V Ceramic, Fast Blow
Status Contact Fuse Rating	250mA / 125V Ceramic, Fast Blow
Replacement Main Fuse	Littelfuse 0314005.HXP
Replacement Status Contact Fuse	Littelfuse 0453.250 or 0451.250

## 1.6 | Common Applications & Optional Hardware

Below are examples of some of the many applications that the PF2100 can be used in.

Line Heater	Tank Heater	Gas Production Unit
Dehydrator	Separator	Amine Reboiler
Combustor	Treater	Thermal Oxidizer

Depending on your installation type, other components may be required. Commonly requested hardware

includes:

### Mounting Hardware

Channel Bar  
Conduit Ports  
Liquid Tight Ports  
Rubber Grommets

### Wire

Ignition Wire  
Thermocouple Wire

### Rods And Connectors

Kanthal Ignition Rods (Various Lengths)

### Valves

DC Solenoids  
Safety Valves with Proof of Closure  
Proportional Valves

### Thermocouples

Single, Type K  
Dual Element, Type K

### Pilot Assembly

Nozzles  
Brackets  
Mixers  
Orifices

### Autonomy

Batteries  
Solar Chargers  
Solar Panels

### Accessories

Modbus Expansion Cards  
4-20mA Repeater Expansion Cards  
Data Logging Expansion Cards  
External Ignition Coil

Please contact Profire Sales for further information.

## 1.7 | System Diagram

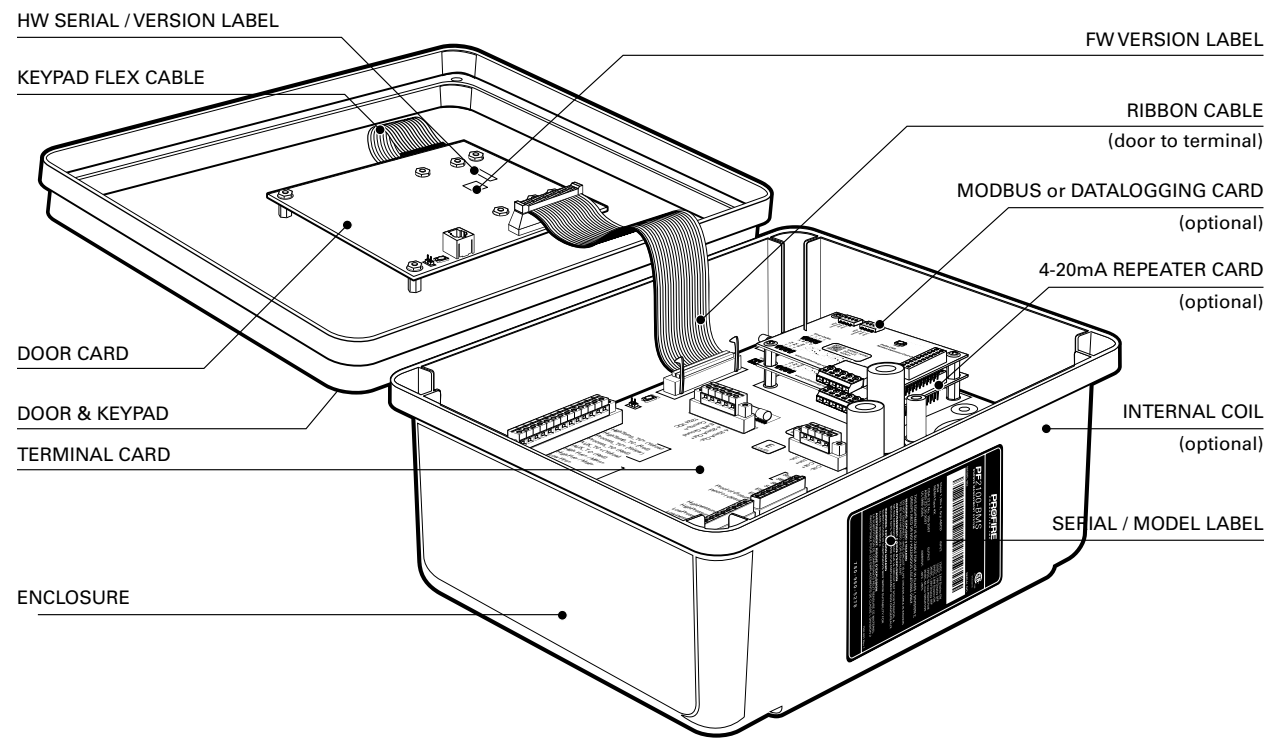

## 1.8 | Terminal Card Descriptions

This table provides connection details and a brief description of each terminal.

TERMINAL	EXPECTED CONNECTIONS	DESCRIPTION
12/24VDC	Input power from a DC source	Input power 10VDC- 28VDC, 5A MAX
Common	Ground back to DC source	Internally connected to EGND
EGND	Earth Ground	
4-20mA Out +	Proportional Valve positive terminal or PLC 4-20mA positive input	This output can be used for either Proportional Valve Control or echoing the Process Temperature to a PLC.
4-20mA Out -	Ground return for the 4-20mA output	A resistance of 120Ω to 250Ω is expected.
HighTemp_TC + (YELLOW)	High Temp Thermocouple positive lead	"TYPE K" thermocouple must be connected between the "+" and "-" terminals and must not be electrically connected to ground.
HighTemp_TC - (RED)	High Temp Thermocouple negative lead	
Process_TC + (YELLOW)	Process Thermocouple positive lead	An uninterrupted connection using "TYPE K" thermocouple wire is required for an accurate reading.
Process_TC - (RED)	Process Thermocouple negative lead	
AUX_TC + (YELLOW)	Aux Thermocouple positive lead	
AUX_TC - (RED)	Aux Thermocouple negative lead	

TERMINAL	EXPECTED CONNECTIONS	DESCRIPTION
High Fire/Main +	High Fire / Main Valve positive terminal	Solenoid valves must be connected between the "+" and "-" terminals. The negative terminal is not directly connected to ground so a common return wire for the High Fire, Low Fire and Pilot valves cannot be used.
High Fire/Main -	High Fire / Main Valve negative terminal. Do not connect to ground.	
Low Fire +	Low Fire Valve positive terminal	Maximum continuous current is 2A. If Low Power mode is enabled, a peak load of 4A is permitted.
Low Fire -	Low Fire Valve negative terminal. Do not connect to ground.	
Pilot +	Pilot Valve positive terminal	Pilot Valve positive terminal
Pilot -	Pilot Valve negative terminal. Do not connect to ground.	
Ion +	Flame Detection positive input. Connect to flame rod or external coil Ion terminal (depending on configuration)	A Kanthal rod should be placed directly in the pilot flame and connected to this input. The pilot assembly must be grounded for the flame detection to function properly. Input is protected from high voltage and can be connected in series with the high voltage terminals of an external ignition coil, allowing a single flame rod to be used for both ignition and flame detection.  A 65VAC signal is applied to the flame rod. The source impedance is very high so there is no danger of sparking.
Ion -	Flame Detection negative input. Connect to ground screw on pilot assembly or burner housing.	Ground return for flame detection.
Coil +	Driver for the low voltage primary of the ignition coil.	The primary of the ignition coil should be connected to this terminal. The 12/24VDC input power will be applied for 1 ms and turned off for 50 ms while sparking.  This output is protected by a 250mA thermal fuse.
Coil -	Ground return for the ignition coil.	

TERMINAL	EXPECTED CONNECTIONS	DESCRIPTION
Status +	Connect to PLC positive input contact or other alarm device.	The status "+" and "-" contacts will be closed when the system is running and opened when the system is shutdown. Dry contact output to indicate system status to an external device. ie. PLC. Note that the contacts are DC only and are not internally connected to power or ground.  40VDC, 250mA, 15Ω
Status -	Connect to PLC negative input contact or other alarm device.	
Start +	Remote start input from an external device. ie. PLC.	Dry contact switch is expected. The input is internally pulled up to 9VDC via a 3.75kΩ resistance. Jumper "+" and "-" if not used.
Start -	Ground	
ESD +	External Shutdown input, typically plant ESD loop.	All input contacts can use a single common ground return if desired.
ESD -	Ground	
Proof of Closure +	Proof of Closure from main valve(s).	
Proof of Closure -	Ground	
High Pressure +	Input from a mechanical High Pressure switch.	
High Pressure -	Ground	
Low Pressure +	Input from a mechanical Low Pressure switch.	
Low Pressure -	Ground	
Level +	Input from a float-switch mounted in the bath.	Dry contact switch is expected. The input is internally pulled up to 9VDC via a 3.75kΩ resistance. Jumper "+" and "-" if not used.  All input contacts can use a single common ground return if desired.
Level -	Ground	

## 2 | INSTALLATION

The PF2100 can be used with many different systems. Before you begin installation, identify which system the BMS will be used to control. In addition to this document, Profire has an Installation Guide and several installation specific Whitepapers available describing common scenarios. These can be found at [www.profireenergy.com](http://www.profireenergy.com).

The steps provided here are general and can help you to identify questions that need to be answered to complete the installation process. If you are new to the PF2100, you should read this whole section and follow the instructions closely.

### Steps

1. Review all installation warnings
2. Install the system
3. Connect the required wiring including Power, Valves, Thermocouples, and Ignition Coil / Flame Detection wiring
4. Connect any additional wiring as required for your specific application. Commonly used lines include the Status Contact, Dry Contact Inputs, 4-20mA Temperature Output, and Expansion Cards

To know which options are required, you should consult the engineer or technician who designed the site. You should also be familiar with the local electrical and gas code for the site.

### 2.1 | Installation Warnings

Before installing the PF2100, please review the following list of warnings. Failure to consider these warnings may result in death, electrocution, property damage, product damage, and/or government fines.

1. The PF2100 is not intended for use on burners greater than 12.5 MMBtuh. It is against code in many locations.
2. To use the PF2100 on burners greater than 5 MMBtuh, it is recommended that the low fire feature with two safety shutoff valves be used. At least one of these valves should use Proof of Closure. This is required in many locations.
3. Failure to properly ground the pilot assembly back to the PF2100's Ion terminal may result in accidental electrocution, product damage, or simply failure to ignite the pilot.
4. The PF2100 generates 20kV- 40kV at its high voltage output terminal which can cause cardiac arrest. Do not touch or place any object near the ignition coil's high voltage terminal or connected ignition wire while the product is operating. Even without making physical contact with the terminal, it is possible to draw a spark from several inches away, especially if the pilot bracket is not properly grounded.
5. Never leave the PF2100 running unattended without the door screws securely tightened down. This is to prevent moisture from getting inside of the enclosure and damaging



the product. Moisture damage to the internal circuitry is not covered by the product warranty if the door has been left open.

6. All conduit ports drilled into the PF2100 enclosure must be CSA/NEMA Type 4 rated and be sealed in order to maintain the Type 4 rating.

## 2.2 | Mounting Considerations

The PF2100 is typically mounted near the burner it is controlling or in another location that is both safe and easily accessible. The recommended mounting height is 1.5m (5ft) above the ground or platform for the comfort of the operators.

### PLEASE CONSIDER THE FOLLOWING WHEN CHOOSING AN INSTALL LOCATION:

#### Accessibility

The system should be easily accessible so that the operator can change settings and observe its operation. It is preferable that the system be mounted facing away from the sun to make it easier to read the display and LED indicators on the front panel.

#### Security

In some situations, it may be desirable to mount the system in a location not accessible to the general public to prevent accidental or intentional tampering.

#### Operator Safety

Avoid placing the system in locations that are dangerous to the operator. Examine the area surrounding the potential installation site and look for such things as nearby open flames or close proximity to tanks that might overflow, and other harmful situations.

#### Performance

Choose a mounting location that allows ground and ignition wires to be kept as short as possible. This ensures the best ignition and flame detection.

#### Product Protection

To protect the system from being damaged, it should not be mounted:

1. Where chemicals may splatter or bubble over from a tank onto

the system. Chemicals on the keypad may interfere with an operator's ability to control the product or view the display and LED indicators.

2. Directly to a heated tank where excessive heat may damage the product. Refer to the maximum operating temperature listed in this document.
3. On anything that may tip over due to wind or snow. Some examples include poles not set properly into the ground or tripods not secured with anchor bolts or guy wires.
4. In locations that may be prone to flooding.

### CONDUIT AND CABLE CONSIDERATIONS

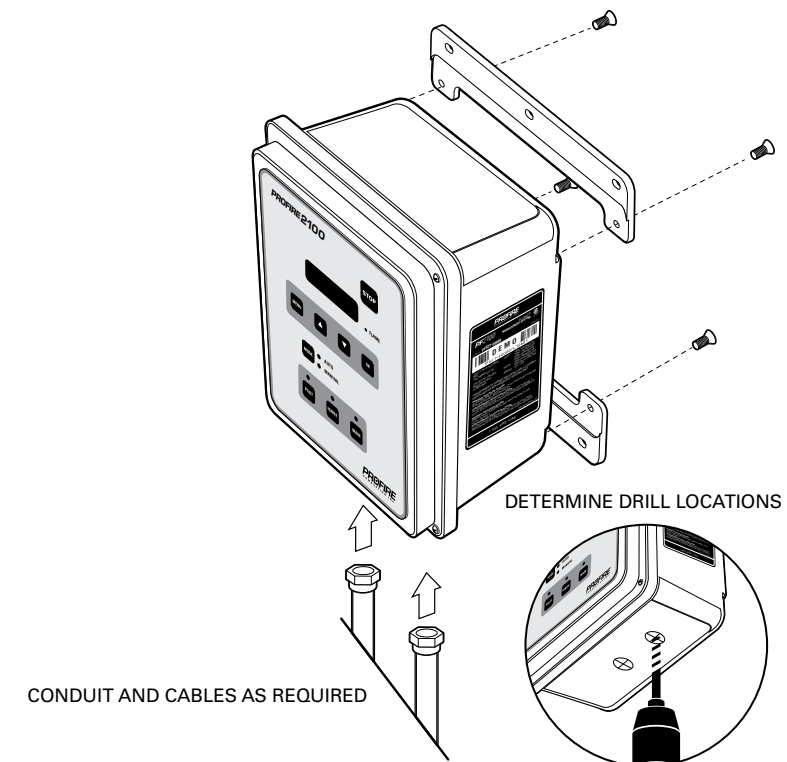

### MOUNTING INSTRUCTIONS

1. Remove the included bag of components taped to the mounting brackets.
2. Attach the two mounting brackets to the back of the PF2100 enclosure using the 4 provided screws.
3. Determine the best location to drill holes in the product enclosure for the wires to enter. It is recommended that these holes be drilled on the bottom of the enclosure (as shown).
4. Install grommets or conduit ports as required.



- Securely mount the enclosure to a pole, structure or building as indicated by the site engineer or technician.

## 2.3 | Terminal Card Diagram

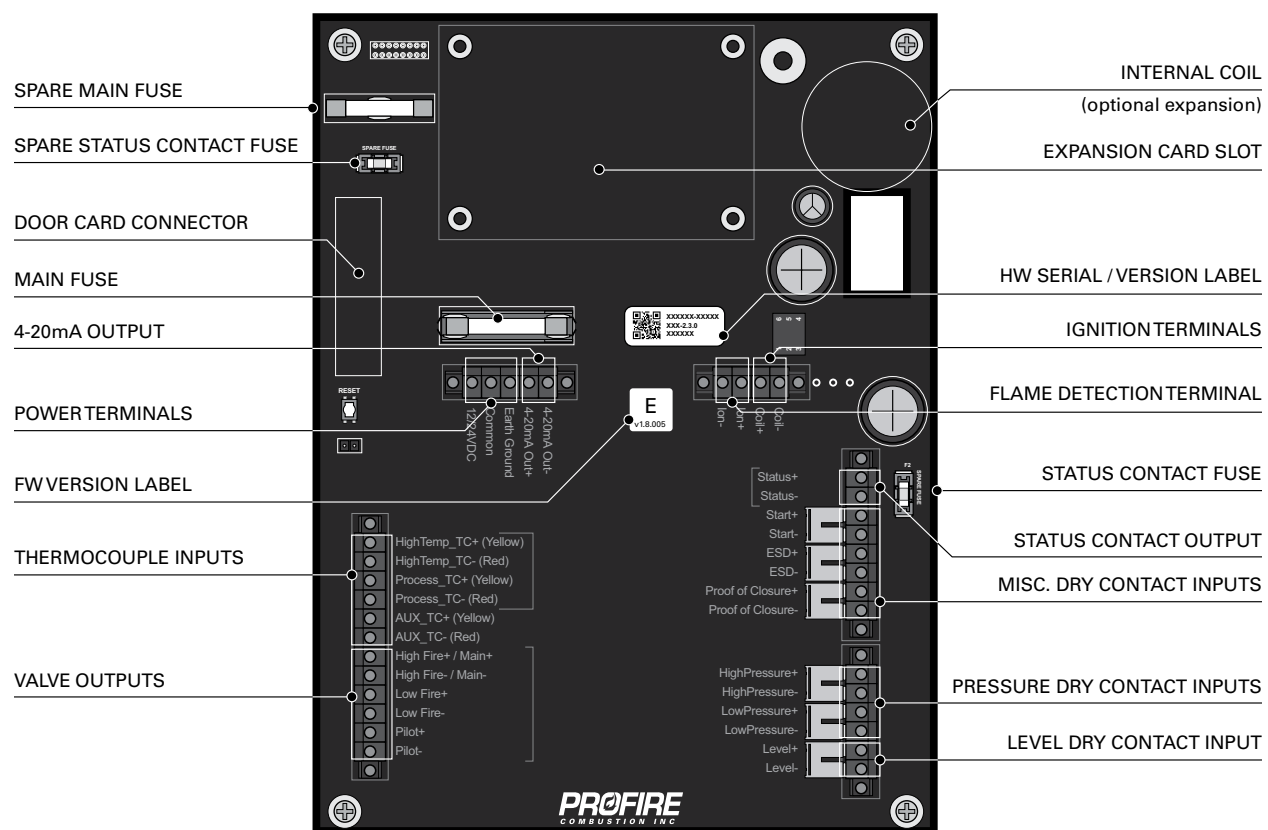

## 2.4 | Wiring

The wiring precautions in this section are important for all PF2100 installations. Please set up your installations accordingly.

NOTE: If you have not wired a PF2100 system, please refer to the PF 2100 Install Guide for detailed wiring instructions. Skipping or performing any steps in the guide incorrectly can result in the PF2100 not functioning properly.

### POWER

The PF2100 can be powered from 12VDC or 24VDC. The maximum current that the PF2100 can safely handle without blowing the main fuse is 5A. The system on its own draws about 100mA. The rest of the current is used by additional hardware such as valves. Make sure that you select a power supply that is

rated appropriately for the total amount of current that will be consumed by all devices attached to it.

### VALVES

There are four valve control outputs on the PF2100: Pilot, Low Fire, 4-20mA Output, and High Fire/Main. Ensure that each valve has a separate return wire. Multiple valves sharing common return wires will not function properly.

#### Pilot Valve

The Pilot valve is required and must be wired for all installations.

#### Low Fire Valve

The Low Fire valve may also be required by local code or for proper operation of your particular application. Low Fire is often used on high Btuh burners (burners that exceed 5 MM Btuh) to establish a draft before opening the High Fire valve. Failure to do this on high Btuh burners can cause the burner to starve itself of oxygen which puts out the flame.

#### 4-20mA Output

The 4-20mA Output can be used to control a proportional valve designed for a 4-20mA current loop. Using a proportional valve allows for finer control of the burner's temperature as opposed to the 2 or 3 levels possible with normal valves. Typically the 4-20mA Output is used in conjunction with a normal valve. The 4-20mA Output also supports low fire.

#### High Fire/Main Valve

The High Fire valve is required and must be wired for all installations. This valve is sometimes called the Main Valve, especially when Low Fire is not used.

NOTE: It is possible to connect multiple valves to the same control output in parallel or series. If you do this, be sure that the configuration you are using meets local codes and does not exceed the total current rating of the PF2100.

NOTE: The negative valve control wires are NOT connected directly to ground. Therefore, you cannot use a common return wire for all valves.

### THERMOCOUPLES

The High Temp and Process thermocouple inputs are mandatory and must be connected to a Dual Element thermocouple. The Auxiliary thermocouple is only needed when a second process temperature (such as the outlet temperature on a line heater) must be monitored. Otherwise, the Auxiliary thermocouple terminals can be left unconnected.

All thermocouples are cold junction compensated. For this reason, it is important to make sure that Type-k thermocouple wire and connectors are used exclusively. The temperature compensation is done using an ambient temperature sensor located on the terminal card near the thermocouple terminals.

#### Process Thermocouple

This thermocouple is normally used on the primary temperature control device. The system shuts down if an open circuit is detected on this thermocouple. It should be placed in the same thermowell as the High Temp thermocouple using a dual element thermocouple.

### High Temperature Thermocouple

This thermocouple is used for the high-temp shutdown. The system shuts down if an open circuit, short-circuit or short-to-ground is detected on this thermocouple. It should be placed in the same thermowell as the Process thermocouple using a dual element thermocouple.

### AUX Thermocouple

This thermocouple is optional and can be enabled in menu 5. It can be used to monitor stack temperature or to control a secondary process temperature. The system shuts down if an open circuit is detected and the AUX thermocouple is enabled.

### All Thermocouples Must Be:

- Isolated from ground
- Isolated from power
- Type-k thermocouples
- Connected with 20 AWG or larger Type-k extension wire
- Placed a safe distance from high voltage lines and shielded when necessary

### STATUS CONTACT

The status contact is a dry contact output containing a solid state relay. It acts as a switch that the PF2100 controls. Neither contact is internally connected to power or ground so these connections must be provided externally as required. When the system is running, the contacts are internally connected together and when the system is not running, the contacts are open circuited. These contacts are often used for monitoring the PF2100's status remotely. An alarm, siren, trouble lamp, or PLC are examples of devices that might use this contact.

THE STATUS CONTACTS ARE RATED FOR DC ONLY so it is important to observe the correct polarity when attaching a device. The positive status contact terminal should always be at a voltage potential greater than or equal to the negative terminal. Do not exceed the voltage and current ratings which are 40VDC, 250mA. The impedance when closed is 15Ω. There is a fuse on the status contact to protect it. A spare fuse is also included.

### DRY CONTACT INPUTS

There are 6 dry contact inputs on the PF2100. The expected connection to each of these is a switch. These contacts must all be closed (shorted) in order for the system to start. Jumpers are provided for each of these by default. If you need to use a particular contact for your application, simply remove the associated jumper and connect a switch in its place.

#### Start Contact

The Start Contact can be used to attach a remote start/stop switch. This is often connected to a PLC dry contact output. When the contact is open, the system is stopped. For safety reasons, a double action is required to start the system remotely via this contact. This is accomplished by closing the switch, opening it, and then closing it again. Once the system is running, open the switch again to stop it.

#### ESD Contact

The ESD Contact can be used to attach an emergency shutdown switch. This is often connected to a mushroom switch mounted on a remote panel or to a PLC dry contact output.

When the contact is open, the system is stopped. The system cannot be started via this contact but this contact must be closed in order to start the system.

### Proof of Closure Contact

The Proof of Closure Contact can be used to receive the feedback signal from a Main Valve that has a Proof of Closure output. If multiple main valves with Proof of Closure outputs are used, these can be wired together in series. Before the system attempts to light the pilot, it will check that the Proof of Closure Contact is closed. If it is open, it will not light the pilot.

### High Pressure Contact

The High Pressure Contact can be connected to a High Pressure Switch installed in the fuel train. Typically, this switch is placed immediately after the Main valve in the fuel train. See the [4-20mA Expansion Card](#) section for more details.

### Low Pressure Contact

The Low Pressure Contact can be connected to a Low Pressure Switch installed in the fuel train. Typically, this switch is placed immediately before the Main valve in the fuel train. The Low Pressure Contact operates using averaged time to help reject brief fluctuations in gas pressure. The contact must be open continuously for 2 or 6 seconds (depending on the "Pressure/Level Delay" setting) before the system will shut down. If "Auto Restart" is enabled, the system restarts automatically when the Low Pressure Contact re-closes. See the [4-20mA Expansion Card](#) section for more details.

### IGNITION COIL / FLAME DETECTION

This section provides some tips to set up the system for reliable ignition and flame detection.

#### Internal vs. External Coil

If less than 5m (15ft) of ignition wire is required to connect the PF2100 to the burner housing, the internal coil configuration can be used. Otherwise the external coil configuration must be used.

The PF2100 system is available with an internal coil or an external coil can be purchased with or without a separate enclosure.

#### Wire Lengths

When wiring the ignition and flame detection circuits, the wire length must be carefully considered. If the wire lengths are too long, the PF2100 may not be able to deliver enough energy to the ignition rod to ignite the pilot. The PF2100 may also fail to receive a signal from the flame rod for detecting flame.

#### Grounding

Properly grounding the pilot assembly back to the PF2100 is critical for proper ignition and flame detection. A ground wire should run from the Ion- or EGND terminal of the PF2100 to the pilot assembly. This wire can either be connected to a ground screw on the pilot bracket or to the burner housing. If connected to the burner housing, use a multimeter to verify that the burner housing has electrical continuity with the pilot assembly. If not, another wire must be added to connect it.

#### Single Rod vs. Dual Rod

A single Kanthal rod can be used for both ignition and flame detection to save cost if desired. This often results in a performance trade-off between ignition and flame detection. This option is only available with external coils.



Using two Kanthal rods (one for ignition and one for flame detection) allows for greater flexibility in rod placement and often yields better performance.

Note that there are three possible ways to wire the ignition coil and flame detection circuit with the PF2100 as illustrated in the table.

CONFIGURATION (COIL TYPE)	SINGLE ROD	DUAL ROD
Internal Coil		•
External Coil	•	•

### Single Rod Coil Wiring

Use this configuration when you want to save cost by using a single rod.

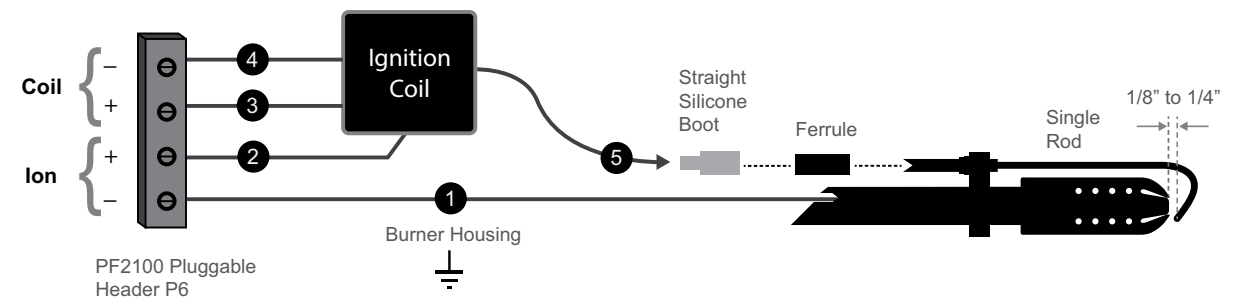

Distance Between 2100 and Pilot*	Wire Size	Hardware Version
0 to 10 feet	14 to 16 Gauge	V 1.7 Terminal Card
10 to 25 feet	7mm Ignition Wire	V 1.7 Terminal Card
25 to 60 feet	7mm Ignition Wire	V 2.4 Terminal Card

\*For single rod installations, the distance is defined as the length 2 plus 5 as shown in the Single Rod Coil Wiring Diagram. Note that wire 5 should be no longer than 10 ft.

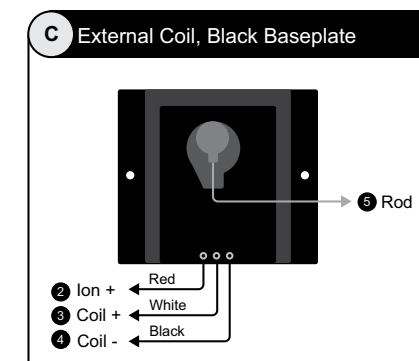
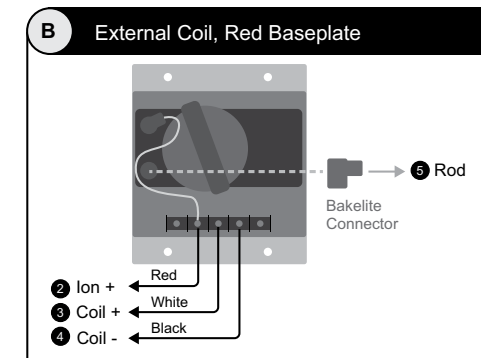
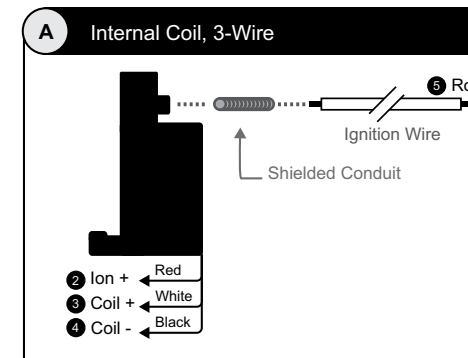

### Dual Rod Coil Wiring

Use this configuration when you want greater flexibility for rod placement.

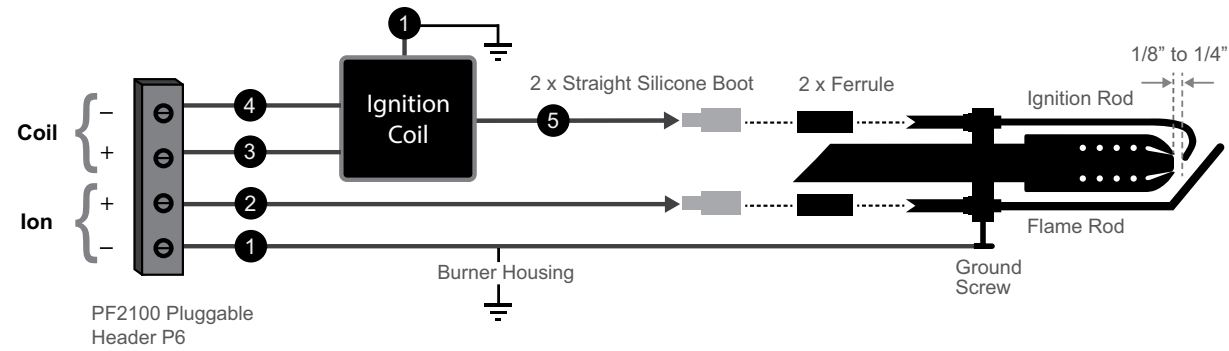

Distance Between 2100 and Pilot*	Wire Size	Hardware Version
0 to 10 feet	14 to 16 Gauge	V 1.7 Terminal Card
10 to 25 feet	7mm Ignition Wire	V 1.7 Terminal Card
25 to 60 feet	7mm Ignition Wire	V 2.4 Terminal Card

\*The distance is defined as the length of 2 as shown in the diagram.

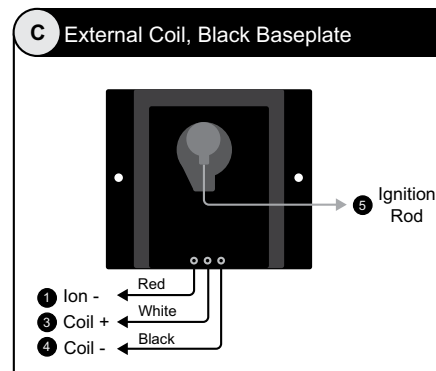
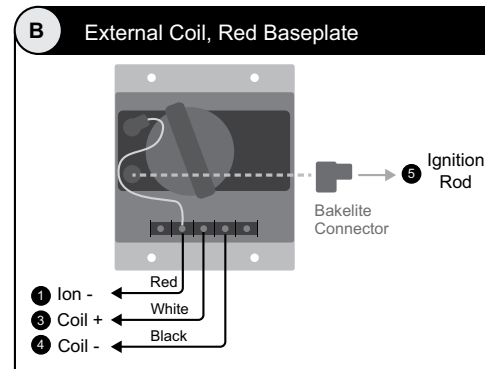
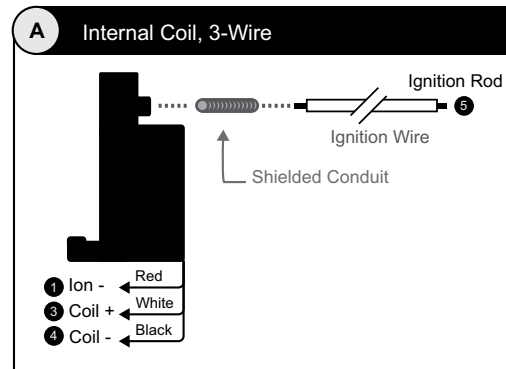

### Rod Positioning

Rod positioning is important for proper ignition and flame detection. The ignition rod should be positioned (by bending it if necessary) so that there is a  $\frac{1}{8}$ " to  $\frac{1}{4}$ " gap between it and the front of the pilot nozzle. The flame rod should be positioned (by bending it if necessary) such that 2" to 3" of its length is within the pilot flame. Make sure the ignition rod and flame rod are not directly in line with each other. Otherwise, the ignition rod may cast a shadow on the flame rod and cause the system to determine that no flame is present at the flame rod.

### Flame Anchoring

Flame anchoring refers to how much in contact the flame is with the pilot nozzle. Poor flame anchoring causes poor flame detection. Poor flame anchoring can be caused when there is too much gas pressure resulting in the flame burning primarily outside of the nozzle as opposed to along the inside and outside surfaces of the nozzle. It can also be caused by wind or draft from the main burner.

### Using Extra Rods to Improve Flame Detection

In some challenging installations such as non-enclosed or high velocity burners, adding one or two additional rods may be necessary. A second flame detection rod can help in cases where the flame may blow away from the primary rod from time-to-time. The addition of a ground rod positioned further away from the nozzle tip can assist with detecting flames that are not well anchored.

# 3 | USER INTERFACE & SETTINGS

The user interface has keys, indicator lights, and a display screen for the software interface (including things such as menus and status screens).

## 3.1 | User Interface

The physical interface consists of three parts:

1. An illuminated display
2. Indicator lights
3. A keypad

### DISPLAY

The screen on the PF2100 displays two lines of text which are used to show system status, warnings, alarms, prompts, and menus. It is illuminated for ease of reading in both bright sunlight and darkness.

When the system first powers on, the display will show the system name and firmware version for a few seconds, after this it will show the Home Screen.

### KEYPAD DIAGRAM

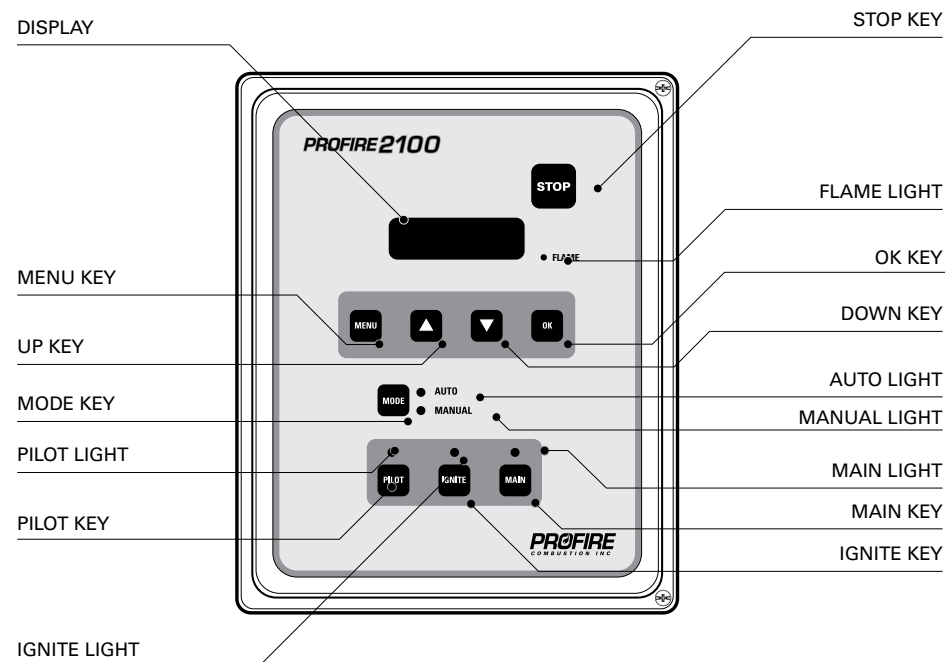

### INDICATOR LIGHTS

#### Flame Light

Indicates that the system is detecting the pilot flame.

#### Auto Light

Indicates that the system is running in auto mode.

#### Manual Light

Indicates that the system is running in manual mode.

#### Pilot Light

Indicates that the pilot valve is open.

#### Ignite Light

Indicates that the system is sparking to ignite the pilot.

#### Main Light

Indicates that the main valve is open.

### KEYS

#### Stop Key

Used to stop the system immediately or in other words, turn off the burner.

#### Menu Key

Used to navigate through the menu.

#### Up Key

Used to adjust a setting upwards and to scroll up through lists.

#### Down Key

Used to adjust a setting downwards and to scroll down through lists.

#### OK Key

Used to enter a menu, acknowledge a prompt, save an edited setting, or return to the home screen.

#### Mode Key

Used to toggle between Manual and Auto modes of operation.

#### Pilot Key

Used in Manual Mode to test the Pilot Valve.

#### Ignite Key

Used in Manual Mode to test the Ignition Circuit.

#### Main Key

Used in Manual Mode to test the Main Valve.

## 3.2 | Menu Navigation

The software user interface is shown on the PF2100 display. While the system is powered, the state of the system is displayed on the screen. The user can also change settings via this interface. Below is a diagram showing the various types of information that can be accessed through the interface. The default system screen at startup and when idling is the Home Screen. Most items are accessed through the Home Screen but some can be accessed from anywhere in the interface.

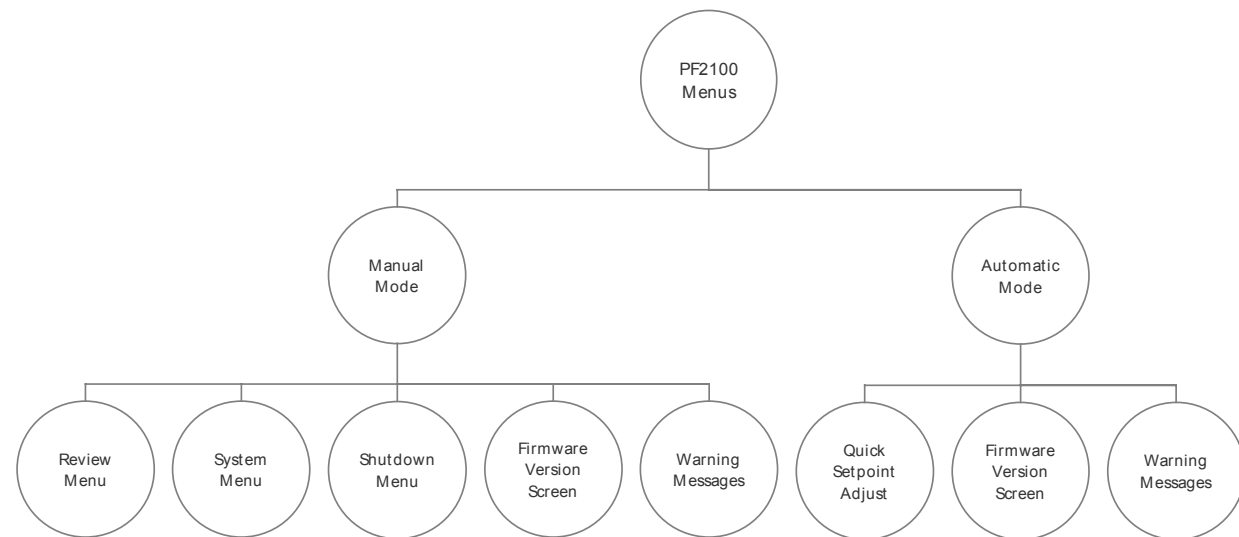

Certain settings can be viewed only in Manual Mode or only in Auto Mode.

### MANUAL VS. AUTO MODE

When the system first powers on, it will normally be in Manual Mode. If the Auto Restart feature is enabled and no alarm conditions are present, it may switch automatically to Auto Mode after power up. Otherwise, the user must manually put the system into Auto Mode by using the Keypad, the Start Contact, or the Modbus Expansion Card. See the [System Start Up](#) section for more details.

The main difference between these two modes is that all settings can be adjusted in Manual Mode and a limited number of settings can be adjusted in Auto Mode. The following table illustrates the differences in menu access.

ITEM	MANUAL MODE	AUTO MODE
User Can View and Adjust Menu Settings	Yes*	via Quick Setpoint Adjust
User Can Access the Review Menu	Yes	No
Process Control Can Be Running	Yes	Yes
System will try to Relight the Burner if the Pilot is Turned Off Due to Normal Process Control	Yes	Yes
System State Shown on the Home Screen	Always	During State Change
System will Attempt to Relight the Burner if the Flame Goes Out Unexpectedly	No	Yes
Process Setpoint can be Easily Adjusted via the "Quick Setpoint Adjust" feature	No	Yes
The System can be Controlled Manually via the Pilot, Ignite, and Main keys	Yes	No
Manual Indicator Light On	Yes	No
Auto Indicator Light On	No	Yes

\*Menus 1-3 only when process control is running, all menus when stopped.

### HOME SCREEN

The Home Screen is shown on the display after power up, after waking the display from sleep, and after the user acknowledges a shutdown message. It is the starting point for most user interaction with the menu system. To return to the Home Screen from any point in the user interface, the user can press and hold the "OK" key for three seconds.

On the Home Screen, the Process Temperature is always shown on the bottom line of the display. The top line differs depending on mode. In Manual Mode, the top line shows the system state. In Auto Mode, it shows the Process Setpoint instead.

The accessibility of other features from the Home Screen also differs depending on mode. For example, the System Menus and Review Menu are only accessible in Manual Mode whereas the Quick Setpoint Adjust feature is only available in Auto Mode. For more information on which features are available in which modes, refer to the [Adjust Settings & Review Status](#) section.

## AVAILABLE FEATURES WITHIN OPERATIONAL MODES

MODE	DISPLAY	MENUS	REVIEW	SETPOINT ADJUST
Manual	System State Process Temperature	Yes	Yes	No
Auto	Process Setpoint Process Temperature	No	No	Yes

## SYSTEM STATE

The System State is the Process Control State of the system. It is shown on the display for a few seconds before and after a state change. In Manual Mode, the top line of the Home Screen always shows the System State. Go to the [Process Control Settings](#) section for a complete list of the Process Control States.

## QUICK SETPOINT ADJUSTMENT

The Quick Setpoint Adjust feature is only available on the Home Screen while running in Auto Mode. It allows the user to quickly adjust the Process Setpoint using the up and down keys. The change takes effect immediately and does not need to be saved by pressing ok. If password protection is enabled, a password will need to be entered before this feature can be used. If the Pilot Off and/or Low Fire Setpoints are enabled, this feature will also adjust them. In this case, each press of the up or down key will adjust all of these setpoints by 1 degree up or down. All other setpoints are not affected by this feature.

## SYSTEM MENUS

The System Menus store all of the system settings in an organized fashion. These menus are also used to show historical and system status information as well as to provide access to calibration features. These menus cannot be accessed while the system is running in Auto Mode. Some menus can only be accessed while the system is stopped. Some menus require a Level 2 password and others require an optional Level 1 password.

## REVIEW MENU

The Review Menu provides a quick way for an operator to check key setpoints and system status (accessible only in Manual Mode).

## FIRMWARE VERSION SCREEN

The Firmware Version Screen shows the firmware version of all cards in the system including the Door Card, Terminal Card, and any installed Expansion Cards.

## WARNING MESSAGES

When the system detects a warning condition, it will flash a warning message across the bottom line of the Home Screen. Some messages can be dismissed by pressing the OK key (eg, "Unit restarted from LVL event"). Others persist until the warning condition is resolved (eg, "LO Volt Warning").

## SHUTDOWN SCREEN

When the system shuts down as a result of an alarm condition, it will flash the word "SHUTDOWN" in large text on the display alternately with a more detailed message explaining the reason that the system shut down. The Shutdown Screen can always be dismissed by pressing "OK," toggling the Start Contact, or sending the Start Command via Modbus.

## 3.3 | Menu Map

For a complete description of each item, please refer to the menu definitions section. The debug functions are not shown here; if needed they are located in the [Field Calibration](#) section of the manual.

## NAVIGATION

1. Press MENU until you get to the desired menu.  
(The Review menu is accessible by pushing the Down arrow.)
2. Press OK to select an option.
3. Press MENU until you get to the submenu option you want to change/view.
4. Press  $\Delta$  or  $\nabla$  to adjust the selected setting.
5. Press OK to set the new value.
6. Press MENU to cancel changes.
7. Press OK to exit to the home screen.

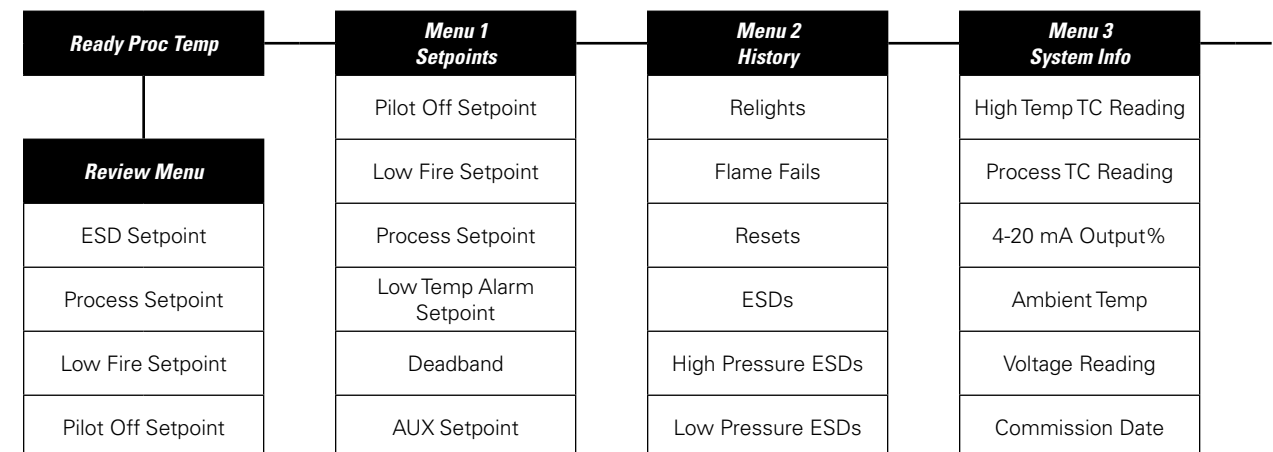

4-20 High Level Setpoint	PID – Proportional Band	Level ESDs	Location
4-20 Low Level Setpoint	PID – Integral	Thermocouple Errors	
4-20 Pressure Setpoint	PID – Derivative	Terminal Errors	
4-20 Low Pressure Setpoint		System Errors	
Flame		View Event Log	
Aux Temp		Clear History	
4-20 Level Reading			
4-20 Pressure Reading			
Alarms			

Commission Date Entry
Commission Location Entry
Rest to Factory Defaults

### SETPOINTS (MENU 1)

This menu is used to adjust the Process Control Setpoints.

MENU MAP	ON SCREEN	BRIEF DESCRIPTION	RANGE	DEFAULT SETTING
Pilot Off Setpoint	Pilot Off Setpnt	Adjusts the temperature at which the Pilot Valve will turn off when Pilot Off is enabled.	1 to 1349°C 34 to 2460°F	85°C 185°F
Low Fire Setpoint	Low Fire Setpnt	Adjusts the temperature at which the Low Fire Valve will turn off when Low Fire is enabled.	2 to 1349°C 36 to 2460°F	Hidden, 85°C 185°F
Process Setpoint	Proc Setpnt	Adjusts the temperature at which the High Fire/Main Valve will turn off	1 to 1349°C 34 to 2460°F	80°C 176°F
Low Temp Alarm Setpoint	Low Temp Alarm Setpnt	Adjusts the temperature where the Status Contact will close, if enabled.	Disabled, 1 to 1349°C 34 to 2460°F	Disabled
Deadband	Deadband	Adjusts the Deadband. Used with the Process Setpoint and sometimes Low Fire and Aux Setpoints.	1 to 150°C 1 to 240°F	2°C 3°F
Aux Setpoint	AUX Setpnt	Adjusts the Auxiliary Setpoint	0 to 1350°C 32 to 2462°F	Hidden, 20°C 68°F
PID – Proportional Band	PID PB:	Expressed in percent, this is inversely proportional to the PID controller's proportional gain.	0.0 to 999.9%	10.0%
PID – Integral	PID I:	Expressed in Minutes per Reset, this is the amount of time required for the PID integral term to yield the same output as the proportional term.	0.0 to 999.9 min/rst	4.0 min/rst
PID – Derivative	PID D:	Expressed in Minutes, this causes the PID to compensate based on the changing error. Disabled by default	0.0 to 999.9 min	0.0 min

### HISTORY (MENU 2)

This menu contains informational event counters and the event log.

MENU MAP	ON SCREEN	BRIEF DESCRIPTION	RANGE	DEFAULT SETTING
Relights	Re-Lights	Number of Pilot Relight attempts.	0 to 1000	N/A
Flame Fails	Flame Fails	Number of Shutdowns due to failure to light the pilot.	0 to 1000	N/A
Resets	Resets	Number of power failures or manual resets.	0 to 1000	N/A
ESDs	ESDs	Number of system shutdowns caused by faults.	0 to 1000	N/A

Menu 4 System Startup	Menu 5 Control Setup	Menu 6 Expansion Cards
Auto Restart	High Temp ESD Setpoint	4-20 Expansion Card Enable
Purge Time	Process Control In-put	4-20 Level Units
Pilot to Main Delay	Low Fire Enable	4-20 Level Range
Restart Attempts	Low to High Fire Delay	4-20 Level Offset
Level Event Restart	Pilot off Enable	4-20 Level Low Setpoint
Pressure/Level Delay	AUX Temp Mode	4-20 Level High Setpoint
Pressure Restart		4-20 Pressure Units
Alarm Mode	4-20 Output Mode	420 Pressure Range
Password Enable	4-20 Low Fire Setting	4-20 Pressure Low Setpoint
Display Sleep		4-20 Pressure High Setpoint
Pilot Valve Power Setting		MODBUS Enable/Address
Main Valve Power Setting		4-20 Card FW Version
System Voltage Setting		MODBUS Card FW Version
Temperature Display Units		



MENU MAP	ON SCREEN	BRIEF DESCRIPTION	RANGE	DEFAULT SETTING
High Pressure ESDs	HPR ESDs	Number of High Pressure Shutdowns.	0 to 1000	N/A
Low Pressure ESDs	LPR ESDs	Number of Low Pressure Shutdowns.	0 to 1000	N/A
Level ESDs	LVL ESDs	Number of Level Contact Shutdowns.	0 to 1000	N/A
Thermocouple Errors	TC Errs	Number of Thermocouple Shutdowns.	0 to 1000	N/A
Terminal Card Errors	Term Errs	Number of Terminal Card Shutdowns.	0 to 1000	N/A
System Errors	Sys Errs	Number of System Errors Shutdowns.	0 to 1000	N/A
View Event Log	View Event Log?	Log of recent events	Yes/No	No
Clear History	Clear History?	Clears all History and logged events	Yes/No	No

### SYSTEM INFO (MENU 3)

This menu contains diagnostic information about the system.

MENU MAP	ON SCREEN	BRIEF DESCRIPTION	RANGE	DEFAULT SETTING
High Temp TC Reading	Hi Temp TC	Current High Temp Thermocouple reading	-50°C to 1350°C	N/A
Process Temp TC Reading	Proc TC	Current Process Thermocouple reading	-50°C to 1350°C	N/A
4-20mA Output Percent	4-20 Output	Current status of the 4-20mA Output	0 to 100%	N/A
Ambient Temp	Ambient Temp	Current ambient temperature. Used for thermocouple cold junction compensation.	-55°C to 65°C -70°F to 150°F	N/A
Voltage Reading	System Voltage	Current voltage applied to the system	8V to 35V	N/A
Commission Date	Commission Date	Date that the system was commissioned (if entered by user)	DD-MMM-YYYY	N/A
Location	Location	The install location of the system (if entered by user)	N/A	N/A
Control State	Control State	Debug Information	N/A	Hidden
Terminal Card State	Term Card	Debug Information	N/A	Hidden

### SYSTEM SETUP (MENU 4)

This menu contains various optional system settings. It cannot be accessed while the PF2100 is running.

MENU MAP	ON SCREEN	BRIEF DESCRIPTION	RANGE	DEFAULT SETTING
Auto Restart	Auto Restart	Enables system to restart from a power failure or high voltage event.	On/Off	Off
Purge Time	Purge Time	Adjusts the time from all valves closed to Pilot relight attempts	10- 900 sec	30 sec
Pilot to Main Delay	Pilot to Main Delay	Adjusts the time from Pilot proven to Main Valve opening	5- 600 sec	15 sec
Restart Attempts	Restart Attempts	Adjusts the number of Restart Attempts after an unexpected flame failure before a shutdown	0- 3	3
Level Event Restart	Level Event Restart	Enables recovery from a Low Level event	On/Off	Off
Pressure/Level Delay	PRS/LVL Delay	Pressure and Level shutdown delay	On/Off	Off

MENU MAP	ON SCREEN	BRIEF DESCRIPTION	RANGE	DEFAULT SETTING
Pressure Restart	PRS Restart	Allows the system to automatically restart when a low pressure event clears. Can also enable control of the main valve based on the Low Pressure Contact or Low Pressure Setpoint.	Enabled, Disabled, Main Control	Disabled
Alarm Mode	Alarm Mode	Adjusts the behaviour of Status Contact relative to Start Contact	Alarm when Off, No Alarm When Off	No Alarm when Off
Password Enable	Password	Enable Password Protection (Menu 1-3)	On/Off	Off
Display Sleep	Display Sleep	Enable Sleep Mode for the Display	Never, After 10 Min	Never
Pilot Valve Power Setting	Pilot Solenoid PWM	Adjusts the Pilot Valve PWM duty cycle	Off, 80%, 60%, 40%, 20%	60%
Main Valve Power Setting	Main Solenoid PWM	Adjusts the Main Valve PWM duty cycle	Off, 80%, 60%, 40%, 20%	60%
System Voltage Setting	System Voltage	Configures the expected input voltage for the system	12V, 24V	12V
Temperature Display Units	Temp Units	Configures the temperature units displayed by the system	Fahrenheit, Celsius	Celsius
Commission Date Entry	Commission Date	Set the date that the system was commissioned	DD-MMM-YYYY	01-JUN-2012
Commission Location Entry	Commission Loc	Set the install location of the system. 14 Characters Max.	A-Z, 0-9, -/	
Reset to Factory Defaults	Rest to Factory Defaults?	Restore all settings to the factory default	Yes/No	No

### CONTROL SETUP (MENU 5)

This menu contains various optional Process Control settings. It cannot be accessed while the PF2100 is running.

MENU MAP	ON SCREEN	BRIEF DESCRIPTION	RANGE	DEFAULT SETTING
High Temp ESD Setpoint	High Temp ESD SETPNT	Adjusts the High Temperature shutdown setpoint	2 to 1350°C 36 to 2462°F	90°C 194°F
Process Control Input	Process Control	Configure the thermocouple used as the Process Temperature	Process TC, AUXTC	Process TC
Low Fire Enable	Low Fire	Enables Low Fire feature and setpoint	Disabled, on at Proc Setpnt, on at Low Fire Setpnt	Disabled
Low to High Fire Delay	Low to High Fire Delay	Adjusts the time from Low Fire Valve opening to High Fire Valve opening, when Low Fire is enabled. Values set above 255 seconds are automatically set to the value minus 255 seconds. For example, inputting 275 seconds sets the actual delay to 20 seconds.	30- 300 sec	Hidden, 30 sec
Pilot Off Enable	Pilot Off	Enables Pilot Off feature and setpoint	Disabled, Enabled	Enabled
Aux Temp Mode	AUX Temp Mode	Configures how the Auxiliary Thermocouple is used.	Disabled, Display Only, Temp Main Ctl, Temp ESD	Disabled

MENU MAP	ON SCREEN	BRIEF DESCRIPTION	RANGE	DEFAULT SETTING
4-20 Output Mode	4-20 Out Mode	Configures 4-20 Output mode	Valve Control 1 Valve Control 2, Temp Output	Disabled
4-20 Low Fire Setting	4-20 Out Lo Fire Setting	Sets the minimum output for the 4-20mA Output when used for Valve Control.	0 to 70%	40%

## EXPANSION CARDS (MENU 6)

This menu contains settings relating to [expansion cards](#).

MENU MAP	ON SCREEN	BRIEF DESCRIPTION	RANGE	DEFAULT SETTING
4-20 Input Card Enable	4-20 Input Card Enabled	Enable the 4-20mA Expansion Card and setpoints	No/Yes	No
4-20 Level Units	4-20 LVL Units	Adjusts the display units for the 4-20mA Level Input	%, m3, BBL, GAL, L	Hidden, m3
4-20 Level Range	4-20 LVL Range	Adjusts Max Level of the tank	High Setpoint-1000	Hidden, 0-120m3
4-20 Level Zero Offset	4-20 LVL Zero Offset	Adjusts the level reading corresponding to a 4mA input	0 to Low Setpoint	Hidden, 0m3
4-20 Level Low Setpoint	4-20 LVL Low Setpnt	Adjusts 4-20 Low Level trip point	0 Offset- High Setpoint	Hidden, 60m3
4-20 Level High Setpoint	4-20 LVL High Setpnt	Adjusts 4-20 High Level trip point	Low Setpoint- Level Range Max, Disabled	Hidden, 117m3
4-20 Pressure Units	4-20 PRS Units	Adjusts the display units for the 4-20mA Pressure Input	PSI, kPa, inWC, oz, ksc	Hidden, 0-30.0PSI
4-20 Pressure Range	4-20 PRS Range	Adjusts Max pressure of the fuel train	High Setpoint-999.9	Hidden, 30.0 PSI
4-20 Pressure Low Setpoint	4-20 PRS Low Setpnt	Adjusts 4-20 Low Pressure trip point	0-High Setpoint	Hidden, 3.0 PSI
4-20 Pressure High Setpoint	4-20 PRS High Setpnt	Adjusts 4-20 High Pressure trip point	Low setpoint - Max Pressure. Disabled	Hidden, 25.0 PSI
MODBUS Enable/Address	Modbus Card	Enable control and address for the Modbus Expansion Card	Disabled, 1-254	Disabled
4-20 Card FW Version	4-20 FW	Display Expansion Card FW Version	N/A	N/A
MODBUS Card FW Version	MBUS FW	Display Expansion Card FW Version	N/A	N/A

## REVIEW MENU

This read only menu allows various commonly needed system settings and status parameters to be reviewed while the system is running.

MENU MAP	ON SCREEN	BRIEF DESCRIPTION
ESD Setpoint	ESD Setpnt	Temp at which system will shutdown
Process Setpoint	ProcSetpnt	Temp at which High Fire / Main Valve will turn off
Low Fire Setpoint	LF Setpnt	Temp at which Low Fire Valve will turn off if Low Fire is enabled
Pilot Off Setpoint	Pilot off	Temp at which Pilot Valve will turn off if Pilot is enabled
4-20 High Level Setpoint	HLV	Level at which 4-20mA Output contacts will toggle

MENU MAP	ON SCREEN	BRIEF DESCRIPTION
4-20 Low Level Setpoint	LLV	Level below which the system will shutdown or wait if Level Event Restart is enabled
4-20 High Pressure Setpoint	HPR	Pressure above which the system will shutdown after Main
4-20 Low Pressure Setpoint	LPR	Pressure below which the system will shutdown or wait if Auto Restart is enabled
Flame	Flame	Current Flame Quality
Aux Temp	AUX Temp	Current Aux Temp reading
4-20 Level Reading	LVL	Current 4-20mA Level input reading
4-20 Pressure Reading	PRS	Current 4-20mA Pressure input reading
TC Debug Screen	DH=ww TH=xx TP=yy TA=zz	Shows the current readings of all temperature sensors simultaneously always in degrees celsius regardless of the display unit setting  DH=Door Card High Temp, Thermocouple TH=Terminal Card, High Temp Thermocouple TP=Terminal Card Process Thermocouple TA=Terminal Card Ambient Thermocouple
Alarms	Alarms	Lists up to 3 simultaneous alarm codes if any are present

## 3.4 | Initial System Settings

The following settings need to be modified for every installation.

1. Valve Modulation Settings (Pilot and Main)
2. System Voltage
3. Process Control Settings
4. Process Setpoints (High Temp ESD, Pilot Off, Process, Low Fire, Low Alarm, Deadband)

### VALVE MODULATION SETTINGS

The Pilot and Main Valve outputs can be modulated with a pulsed DC signal to conserve power using Pulse Width Modulation (PWM). The duty cycle of the modulation can be adjusted independently for each valve. Each can be set to 100%, 80%, 60%, 40%, or 20%. The 100% setting applies continuous DC voltage (ie, no modulation) to the valve and is the highest power option. The 20% setting applies DC voltage 20% of the time and is the lowest power option. Only valves that are compatible with modulation should be used with a duty cycle of less than 100%. These valves are sometimes called "Low Power" or "Peak-and-Hold" valves since they require only short periodic voltage pulses to hold the valve open. Do not use a duty cycle of 100% with low power valves as this can damage them.

If a multimeter is used to measure the valve power, the measured voltage will be reduced proportionally with the PWM setting.

The pilot and main valve power settings can be adjusted to match the needs of various applications.

#### Pilot Valve Power Setting (Menu 4)

Adjusts the PWM Duty Cycle of the Pilot Valve output.

#### Main Valve Power Setting (Menu 4)

Adjusts the PWM Duty Cycle of both the Low Fire and High Fire Valve outputs.

## SYSTEM VOLTAGE

The PF2100 is designed to operate with a nominal 12VDC or 24VDC Power Supply. The system will not be damaged by applying any voltage in or near this range regardless of menu settings. Note that attached valves are typically not designed to accept both 12VDC and 24VDC. If the valve voltage ratings are exceeded, the valves may become damaged.

### System Voltage Setting (Menu 4)

This setting defines voltage limits to protect and allow the proper operation of the attached valves. If the PF2100 detects that the input voltage is getting close to these limits, it will display a warning message. If the voltage exceeds these limits, the system will shut down and cut power to the valves.

The following options are available:

VOLTAGE SETTING	CHOOSE THIS OPTION WHEN...
12 V	The Power Supply and all valves are 12 VDC
24 V	The Power Supply and all valves are 24 VDC

The exact limits used are shown in the following table. Note that the high voltage limits also depend on the Pilot Valve Power Setting and Main Valve Power Setting which can also be found in Menu 4.

V SETTING	PILOT / MAIN VALVE PWM SETTING	LOW V ALARM	LOW V WARNING	HIGH V WARNING	HIGH V ALARM
12V	At least one equal to 100%	<= 8.4V	<= 9.9V	>= 14.6V	>= 15.6V
12V	Both less than 100%	<= 8.4V	<= 9.9V	>= 16.1V	>= 16.8V
24V	At least one equal to 100%	<= 17.9V	<= 19.9V	>= 28.6V	>= 30.0V
24V	Both less than 100%	<= 17.9V	<= 19.9V	>= 33.1V	>= 40.0V

## PROCESS CONTROL SETTINGS

For the PF2100, Process Control refers to controlling the temperature of a process. This process usually involves heating fluid in a tank or pipe. A primary temperature control signal is required for Process Control. This is called the Process Temperature or Proc Temp. Optionally, an auxiliary temperature control signal can also be accepted. This signal is called the Auxiliary Temperature or Aux Temp.

Note that these two signals are not necessarily the same as Proc TC and Aux TC which are the names of the physical thermocouple inputs on the Terminal Card. The Aux Temp signal is only compared to the Aux Setpoint, if enabled.

There are four settings that directly affect Process Control: Process Control Input, Low Fire Enable, Pilot Off Enable, and Aux Temp Mode.

Note that changing any of these settings may cause the Process setpoints (High Temp ESD, Pilot Off, Low Fire, Process, Low Temp Alarm, Deadband, and Aux) to reset to factory defaults. A warning message will display if this occurs.

### Process Control Input (Menu 5)

This setting selects which thermocouple inputs will be used as the primary and auxiliary temperature control signals as shown in the following table.

SETTING	PROC TEMP	AUX TEMP
Proc TC	Proc TC	Aux TC
Aux TC	Aux TC	Proc TC

In previous firmware versions this could also be set to Disabled. In this case, Process Control

was disabled and the system allowed the burner to always be lit and running. The typical use for this was to have an external device, such as a PLC, controlling the process. The PLC would turn the system on and off using the Start contacts. This behaviour can still be achieved by setting all Process Setpoints to maximum.

### Low Fire Enable (Menu 5)

This setting is used to toggle the use of the Low Fire Setpoint for Primary Process Control. Low Fire can be enabled in two different modes: "On at Proc Setpoint" and "On at Low Fire Setpoint". In the first case, the Low Fire Valve will close when it exceeds the Low Fire Setpoint but will not reopen until it drops below the Process Setpoint minus Deadband. In the second case, the Low Fire Valve will close when it exceeds the Low Fire Setpoint and will reopen after it drops below the Low Fire Setpoint minus Deadband.

### Pilot Off Enable (Menu 5)

This setting is used to enable/disable use of the Pilot Off Setpoint for Primary Process Control.

### Aux Temp Mode (Menu 5)

When this setting is set to Temp Main Ctl, Auxiliary Process Control is enabled. See the [Auxiliary Temperature Settings](#) section for more details.

## PROCESS SETPOINTS

There are seven Process Setpoints in total, four of which may be disabled (hidden from menus). The order of the setpoints varies depending on the value of the Process Control Input setting.

The following diagrams illustrate the upper and lower bounds of each setpoint and their order. Setpoints that are shaded may be disabled. When a setpoint is disabled, the upper and lower bounds of the adjacent setpoints are adjusted accordingly.

### Process Control Input Setting: PROC TC

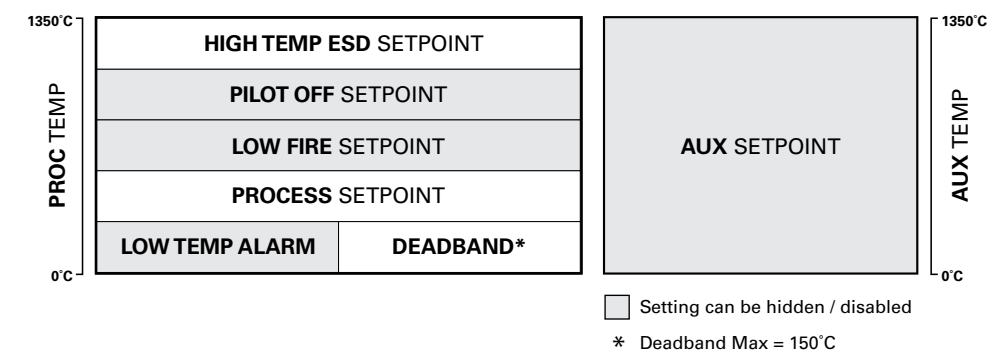

### Process Control Input Setting: AUX TC

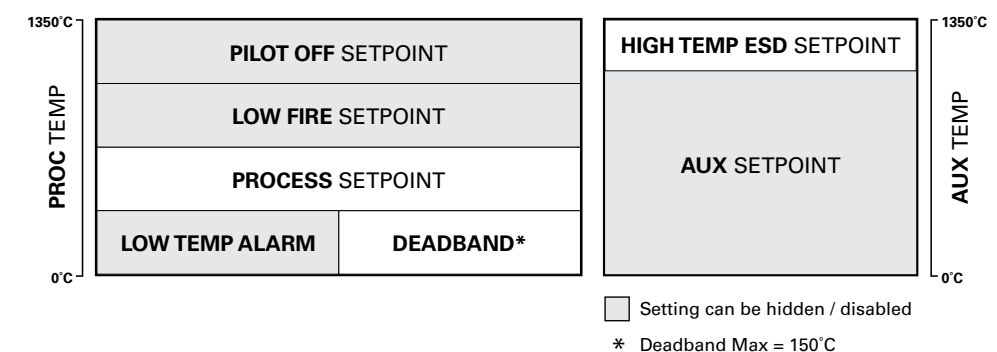

For Process Control, the Proc Temp signal is the one compared to the Pilot Off, Low Fire, Process, and Deadband setpoints.

#### High Temp ESD Setpoint (Menu 5)

This setting is used to protect the burner and other equipment from overheating. If either the High Temp or Process thermocouple readings exceed this setpoint, the burner will immediately shut down. This setting can be set to a maximum of 1350°C. The minimum value is 1°C higher than the setpoint below it. Depending on which settings are enabled, this will be the Pilot Off, Low Fire, or Process Setpoint.

#### Pilot Off Setpoint (Menu 1)

If the Process Temperature goes above this setting, the Pilot Valve will close and the system state will change to "Waiting on Temp." This is often done to conserve pilot gas when it is not needed. This setting is hidden if Pilot Off in menu 5 is set to Disabled. This setting can be set to a maximum of 1°C below the High Temp ESD Setpoint. The minimum value is the same as the setpoint below it. Depending on which settings are enabled, this will be the Low Fire or Process Setpoint.

#### Low Fire Setpoint (Menu 1)

If the Process Temperature goes above this setting, the Low Fire Valve will close and the system state will change to "Pilot On." This setting is hidden if Low Fire in menu 5 is set to Disabled. This setting can be set to a maximum of 1°C below the High Temp ESD Setpoint or the Pilot Off Setpoint if it is enabled. The minimum value is 1°C above the Process Setpoint.

#### Process Setpoint (Menu 1)

If the Process Temperature goes above this setting, the Main Valve will close and the system state will change to "Low Fire." This setting can be set to a maximum of 1°C below the High Temp ESD Setpoint, the Pilot Off Setpoint if enabled, or 1°C below the Low Fire Setpoint if enabled. The minimum value is the Low Temp Alarm or Deadband (whichever is larger).

#### Low Temp Alarm Setpoint (Menu 1)

If the Process Temperature goes below this setting, the Low Temp Alarm will be asserted and the status contact will open. This setting can be set to a maximum of the Process Setpoint value. The minimum value is 1°C. Set to 0°C to disable the Low Temp Alarm.

#### Deadband (Menu 1)

The Deadband setting provides a temperature margin below the Process Setpoint. For the main valve to open, the temperature must be below Process Setpoint minus the Deadband setting.

The Deadband setting also provides a temperature margin below the Low Fire Setpoint when the Low Fire Enable setting is set to "On At Low Fire Setpoint." In this case, the Low Fire valve will open when the Process Temperature is below the Low Fire Setpoint minus the Deadband setting and will close when it is above the Low Fire Setpoint.

The Deadband setting also provides a temperature margin below the Aux Setpoint when the Aux Temp Mode setting is set to "Temp Main Ctl." In this case, the main valve(s) will open when the Auxiliary Temperature is below the Aux Setpoint minus the Deadband setting and will close when it is above the Aux Setpoint.

This setting can be set to a maximum of 150°C or the Process Setpoint, whichever is lower. The minimum value is 1°C.

#### AUX Setpoint (Menu 1)

This setpoint is enabled only if Aux Temp Mode in menu 5 is set to "Temp Main Ctl" or "Temp ESD." In the first case, if the Auxiliary Temperature goes above the Aux Setpoint, the

main valve(s) will close. The pilot will remain on until the Process Temp exceeds the Pilot Off Setpoint (if Pilot Off is enabled). In the second case, the system will shut down if the Auxiliary Temperature goes above the Aux Setpoint. This setting can be set to a maximum of 1350°C. The minimum value is 0°C.

## 3.5 | Optional Settings

### 4-20mA OUTPUT SETTINGS

The 4-20mA Output is built into the Terminal Card (not part of the 4-20mA Expansion Card). It can be used to echo the process temperature to a PLC or control a proportional valve.

#### 4-20 Output Mode (Menu 5)

Set the 4-20mA Output mode to Process Temperature, Valve Control 1, or Valve Control 2.

The 4-20mA Output is intended to drive a proportional valve. The signal is scaled such that 4mA = Valve Closed and 20mA = Valve Fully Open. A PID control loop based on Process Temperature feedback is used to determine how much the valve should be open at any given point in time. More details can be found in the [PID Controller](#) section.

The Valve Controls use a traditional safety solenoid valve connected to the PF2100's Low Fire outputs. The Low Fire setting must also be enabled by setting it to "On at Proc Setpoint."

1. Process Temperature  
In this mode, the 4-20mA Output will encode the Proc Temp signal as a 4-20mA signal. Note that the Proc Temp may correspond to either the Process Thermocouple or the AUX Thermocouple input depending on the Process Control setting. The signal is scaled such that 4mA = 0C and 20mA = the High Temp ESD Setpoint.
2. Valve Control 1  
When the PF2100 enters Low Fire, the proportional valve begins fully closed and linearly ramps so that it reaches the 4-20 Low Fire setting just as the Low to High Fire Delay elapses. Once High Fire begins, the PID Controller adjusts the valve accordingly.
3. Valve Control 2  
When the PF2100 starts, the proportional valve idles at the 4-20 Low Fire setting. Once High Fire begins, the PID Controller adjusts the valve accordingly.

#### 4-20 Low Fire Setting (Menu 5)

This setting is only available when the 4-20 Output Mode is set to Valve Control 1 or Valve Control 2. It specifies the minimum value that the proportional valve will ever be open. This is the starting position of the main valve each time it is turned on. It can be set to any value from 0% to 70%.

### ALARM / STATUS CONTACT SETTINGS

The Status Contact will always open if the system is shut down due to an alarm condition. There are two settings that affect the behavior of the Status Contact: Alarm Mode and Low Temp Alarm Setpoint.



#### Alarm Mode (Menu 4)

The Alarm Mode is used to select whether the Status Contact will open when the unit is stopped remotely via the Start Contact. It can be set to:

1. Alarm When Off  
The Status Contact opens when the unit is stopped (turned off) remotely via the Start Contact.
2. No Alarm When Off  
The Status Contact remains closed when the unit is stopped (turned off) remotely via the Start Contact.

#### Low Temp Alarm Setpoint (Menu 1)

When enabled the Status Contact will remain open until the Process Temperature exceeds this setpoint. See the [Process Setpoints](#) section for more detail.

### AUXILIARY TEMPERATURE SETTINGS

There are two settings that affect the way that the Auxiliary Temperature signal is used by the system: Process Control and Aux Temp Mode.

#### Process Control (Menu 5)

This setting is used to select the thermocouple input that is associated with the Auxiliary Temperature signal. See the [Process Control Settings](#) section for more details.

#### AUX Temp Mode (Menu 5)

Aux Temp mode can be set to any of the following:

1. Disabled  
The Aux Temp signal is ignored by the system.
2. Display Only  
The Aux Temp signal is only used for display purposes. It can be read on the PF2100 display in manual mode via the Review Menu. It can also be read remotely via the Modbus Expansion Card if it is installed and enabled.
3. Temp Main Ctl  
The Aux Temp signal is used as a secondary Process Control input. This modifies the normal Process Control by adding the additional requirement that the signal be below the Aux Setpoint for the main valve(s) to open.
4. Temp ESD  
The Aux Temp signal is used as an auxiliary ESD input. In addition to the normal Process Control, if the Aux Temp signal ever rises above the Aux Setpoint, the system will shut down.

### COMMISSIONING SETTINGS

The date and location of commissioning can be stored in the PF2100. This information is optional and can be input by the customer directly. These two settings can be viewed in menu 3 and edited in menu 4.

#### Commission Date (Menu 4)

This is the date on which the PF2100 was commissioned. Use the Up and Down keys to edit the date and OK to advance to the next date field.

#### Commission Location (Menu 4)

This is the location where the PF2100 was installed. Use the Up and Down keys to edit each character and OK to advance to the next character.

### DISPLAY SETTINGS

There are two settings that affect the behavior of the display: Display Sleep and Temperature Display Units.

#### Display Sleep (Menu 4)

When enabled, the display will turn off to conserve power after 10 minutes of inactivity (no user key presses). Otherwise, the display will always remain on.

#### Temperature Display Units (Menu 4)

The PF2100 always operates in Celsius. This includes storage of temperature setpoints, thermocouple measurements, temperature calculations, and modbus communications. This setting only affects the temperature units on the display. This may lead to small rounding errors when operating in Fahrenheit.

### PASSWORD SETTING

There are two levels of password protection. Menus 1-3 and the Quick Setpoint Adjust feature may be optionally protected by the Level 1 Password. Menus 4-7 are always protected by the Level 2 Password. These passwords cannot be modified.

Level 1 Password: ▲▼▲▲■

Level 2 Password: ▲▼▲▲▼▲■

For convenience, once a password has been entered it unlocks all menus that it protects for a period of time. Therefore it does not need to be re-entered when returning to the menu later. The menu will remain unlocked for 10 minutes or until the user manually locks the menus again. To lock the menus manually, press and hold the OK button for 3 or more seconds. The display will briefly show "Password Logout" to indicate that the menus are locked again.

#### Password Enable (Menu 4)

When enabled, the Level 1 or Level 2 Password must be entered to access menus 1-3 and the Quick Setpoint Adjust feature.

### PID CONTROLLER

A PID Controller is a type of feedback control algorithm commonly used in industrial control applications. The purpose of the controller is to maintain a process variable as close as possible to a user defined setpoint. This is accomplished by continuously measuring the difference between the current value of the process variable and the desired setpoint value and then adjusting some manipulated variable to compensate for the difference. The PID Controller gets its name from the initials of the three tuning coefficients that are built into the control algorithm: the Proportional coefficient, the Integral coefficient, and the Derivative coefficient. These coefficients set the Controller's response to three types of errors: the current error (Proportional), the sum of all past errors (Integral), and the predicted future error (Derivative).

#### PF2100 PID Controller

The PID Controller is used to maintain the Process Temperature as closely as possible to the Process Setpoint. The Controller adjusts the 4-20mA output signal which in turn drives a



proportional valve. The more the valve is open, the more gas passes through, and the more heat is applied to the process. Feedback is provided to the control algorithm by subtracting the thermocouple measurement (the Process Temperature) from the desired temperature (the Process Setpoint).

#### PID Controller (Menu 1)

To perform temperature control with a proportional valve, the PF2100 uses a PID Controller with temperature as its input. The PID Controller uses three parameters to specify how it performs its control: PID–Proportional Band, PID–Integral, PID–Derivative. The default parameters are sufficient for most common heater applications, but they can be tuned for faster control if necessary. See [Appendix A](#) for the recommended tuning procedure for the PID Controller.

### RESTART SETTINGS

The PF2100 can be configured to automatically restart after certain alarm conditions clear. The number of restart attempts is configurable. There are three settings that affect restart behavior: Auto Restart, Level Event Restart, and Restart Attempts.

The number of restart attempts the system will make differs depending on the mode and the reason that the burner is being re-lit.

MODE	PROCESS CONTROL	FLAME OUT
Manual	3	0
Auto	3	User Configurable

#### Auto Restart (Menu 4)

If this setting is enabled, the following conditions will cause the system to enter the “Waiting” state instead of shutting down. In addition, the system will automatically restart once these and all other enabled restart conditions have cleared.

1. System Input Voltage too low (including power cycle)
2. System Input Voltage too high

#### Level Event Restart (Menu 4)

If this setting is enabled, the system will restart automatically once all alarm conditions are cleared and if the reason that the system stopped running was any of the following:

1. Level Contact open
2. 4-20mA Level Input below Low Setpoint

#### Pressure Restart

If this setting is set to “Enabled”, the following conditions will cause the system to enter the “Waiting” state instead of shutting down. In addition, the system will automatically restart once these and all other enabled restart conditions have cleared.

1. Low Pressure Contact open
2. 4-20mA Pressure Input below Low Setpoint

If this setting is set to “Main Control”, the following conditions will cause the system to close the Main Valve instead of shutting down. In addition, the system will automatically reopen the Main Valve once these conditions have cleared and if the temperature control algorithm is also satisfied.

1. Low Pressure Contact open
2. 4-20mA Pressure Input below Low Setpoint

The main valve opening will always occur 7 seconds after the Low Pressure Contact Closes and the 4-20mA Pressure Input rises above the Pressure Low Setpoint. This 7 second delay is comprised of 2 seconds for the pressure measurement to stabilize (to prevent oscillation) plus a 5 second countdown on the screen: “Main on in 5...4...3...2...1...0”

The timing of the main valve closing is determined by the Pressure/Level Delay Setting. Refer to the Pressure Delay Table for details.

Note that the PF2100 always enforces a minimum 30 second delay between any state transition and this situation is no exception. If this delay is unacceptable, the PF3100 system can be used to achieve this same behavior but without this delay.

#### Restart Attempts (Menu 4)

A restart attempt is an attempt by the system to light the burner. These can occur under two types of circumstances:

1. As a result of normal process control. Examples Include:
  - The system is started by a user by switching to Auto Mode.
  - The system is started remotely via the Start Contact.
  - The Pilot Turns off as a result of process control and then is automatically turned back on after the temperature drops below the Pilot Off Setpoint.
  - The system automatically restarts after recovering from one of the situations described in the [Auto Restart](#) or [Level Restart](#) sections.
2. As a result of the pilot flame unexpectedly going out. Examples Include:
  - The gas supply is cut off.
  - Excessive wind blows out the burner flame.
  - Insufficient oxygen supply snuffs out the burner flame.
  - The flame detection rod becomes dirty and unable to detect flame.

### TIMING DELAY SETTINGS

There are four time delay settings that can be adjusted to match the needs of various applications.

#### Purge Time (Menu 4)

This setting is used to set the minimum amount of time that must elapse between when all valves are known to be closed and the next time that the pilot is lit. This will be the minimum elapsed time between relights and also the minimum amount of time before lighting the burner after a loss of power. The purge time ensures that dangerous amounts of gas are not present in the fire tube before the pilot is lit thus reducing the risk of an explosion. Generally, the larger the burner, the larger the purge time should be. Local codes may dictate the amount of purge time required for a given application. This setting can be set to a minimum of 10s and a maximum of 900s.

#### Pilot-To-Main Delay (Menu 4)

This setting is used to set the minimum amount of time that must elapse between the pilot successfully lighting and the main (or low fire) valve opening. The Pilot-to-Main Delay is used to ensure that enough draft is established before opening the main valve. If this is not done, the volume of gas flowing through the main valve can snuff out the flame due to insufficient oxygen supply. Generally, the larger the burner, the larger the delay should be. This setting can be set to a minimum of 5s and a maximum of 600s.

### Low-To-High Fire Delay (Menu 5)

This setting is used to set the minimum amount of time that must elapse between the low fire valve opening and the high fire valve opening. This setting is only available if Low Fire is enabled in menu 5. The Low-to-High Fire Delay is used to ensure that enough draft is established before switching to high fire. If this is not done, the volume of gas flowing through the high fire valve can snuff out the flame due to insufficient oxygen supply. Generally, the larger the burner, the larger the delay should be. This setting can be set to a minimum of 30s and a maximum of 300s. Values set above 255s are automatically set to the value minus 255s.

### Pressure/Level Delay (Menu 4)

This setting is used to reject spurious electrical noise that may be present on the Low Pressure Contact, Level Contact, and the 4-20mA Expansion Card (if installed). This noise can come from electrical interference, mechanical vibration, or small oscillations in gas pressure and tank level. The rejection is accomplished by requiring these contacts to remain open for a continuous period of time (called the "delay") before shutting down. In the case of the 4-20mA Expansion Card, the Pressure and Level readings must remain below their respective low setpoints for the delay time before shutting down. If the Level Event Restart is enabled in the restart settings, the delays are applied before entering a waiting state as opposed to shutting down.

This setting can be set to either enabled or disabled. When disabled, there is a small delay. When enabled, the delay is lengthened. There are separate delays for Pressure and Level, as well as for contacts and 4-20mA input readings. The following tables list the delays used in all cases.

**Pressure Delay Table**

SETTING	LOW PRESSURE				HIGH PRESSURE			
	4-20mA		Contact		4-20mA		Contact	
	Rising	Falling	Opening	Closing	Rising	Falling	Opening	Closing
Enabled		6s	6s	0s	2s	2s	0s	0s
Disabled	2s	2s	2s					

**Level Delay Table**

SETTING	LOW LEVEL				HIGH LEVEL			
	4-20mA		Contact		4-20mA		Contact	
	Rising	Falling	Opening	Closing	Rising	Falling	Opening	Closing
Enabled		20s	20s	0s	0s	0s	N/A	N/A
Disabled	2s	2s	2s					

## 3.6 | System Operation

This section includes information about how to start and stop the system, how to review key system settings, how to adjust setpoints while the system is running, and how to check the system firmware versions.

### STARTING THE SYSTEM

There are five different ways to start the system:

#### Auto Mode Option

The system is set to Manual Mode by default. Setting the system to Auto Mode is the most common way to start the system.

1. Make sure the system is stopped, all alarms are clear, and the Home Screen displays "Ready".
2. Press the Mode Key. A confirmation prompt will show on the Display.
3. Press the OK Key to confirm that you want to start the system.

This changes the system to Auto Mode. Based on the defined system settings, the system will automatically restart from faults. The system will take over turning the valves on and off according to the system settings and the current Process Temperature.

#### System Test And Start Option

This method is used during the initial installation when testing the pilot valve, main valve, ignition circuit, and flame detection circuitry in a slow sequence.

1. Make sure the system is set to Manual Mode and is stopped with all alarms clear. The Home Screen should display "Ready".
2. Press and hold the Pilot Key to open the Pilot Valve. Listen for the Pilot Valve to click open and let the gas through. Continue to hold the Pilot Key and press and hold the Ignite Key to begin sparking. Check the Pilot Nozzle for sparks and flame. If you cannot see the Pilot Nozzle, listen for the sound of sparking and try to determine if it is coming from the ignition rod.
3. Release the Ignite Key and check that the display shows a Flame Quality of 100%.
4. After about 5 seconds, the display will show "Pilot On" if the Pilot lit successfully.
5. Press the Main Key to open the Main Valve. The system will count down the Pilot-to-Main Delay and then open the Main Valve if the Process Temperature is within the expected range.
6. The system will take over turning the valves on and off according to the system settings and the current Process Temperature.
7. Press the Mode Key to switch the system into Auto Mode. This allows the system to automatically restart from faults specified in the system settings.

If any of these checks fail, consult the [troubleshooting](#) section of this guide.

### Automatic Restarts

If the Auto Restart feature is enabled, the system will attempt to automatically start after a power failure. This will only succeed if all alarms are clear.

### Start Contact Option

The Start Contact option can be used to start the system from a remote switch located elsewhere on the site or through a PLC output contact.

1. If there are any Shutdown Messages showing on the display, open the Start Contact and then close it again to acknowledge those messages.
2. Open the Start Contact and then close it again to remotely start the system in Auto Mode. This will only work if all alarms are clear.

### Modbus Card Option (if installed)

This method can be used to start the system via a remote device over a Modbus RTU network.

1. Have the remote device write "1234" to the 40100 register to place the system into Auto Mode.
2. Set the remote device to poll the 40100 register and wait for it to clear to zero. This indicates that the system has processed the command.
3. Set the remote device to poll the 10001 register and wait for it to change to 1. This indicates that the system is running.

## STOPPING THE SYSTEM

There are five different ways to stop the system:

### Stop Key Option

This is the most common way to stop the system.

1. Press the Stop key. The system will stop immediately.

### Auto Key Option

This method of stopping the system is used during the initial installation when testing the pilot valve, main valve, ignition circuit, and flame detection circuitry in a slow sequence.

1. Press the Mode Key to switch the system into Manual Mode. This prevents the system from automatically restarting from faults specified in the system settings.
2. Press the Main Key to close the Main Valve and disable process control.
3. Press the Pilot Key to close the Pilot Valve and stop the system.

### Start Contact Stop

The system can be stopped using the same remote switch or PLC output as with starting the system using the Start Contact input.

1. Open the Start Contact and leave it open. The system will stop immediately.

### Shutdown Conditions

Whenever any shutdown condition is present, the system will stop and stay stopped until the

condition is removed and the fault is acknowledged. Shutdown condition examples include the Process Temperature rising above the High Temp ESD Setpoint, the High Pressure Contact Opening, the ESD Contact Opening, etc. Many conditions can cause shutdowns. Some conditions will only trigger a shutdown if it is enabled in the system settings. See the fault chart in this guide for more details.

### Modbus Card Option (if installed)

This method can be used to stop the system using a remote device over a Modbus RTU network.

1. Have the remote device write "4321" to the 40100 register to stop the system.
2. Set the remote device to poll the 40100 register and wait for it to clear to zero. This indicates that the system has processed the command.
3. Set the remote device to poll the 10001 register and wait for it to change to 0. This indicates that the system has stopped.

## ADJUST SETTINGS & REVIEW STATUS

There are four ways to check and adjust system settings and to view system status:

### Home Screen

The Home Screen is accessible at any time. Press and hold the OK Key for 3 seconds.

1. Manual Mode: The Home Screen displays the System State and the Process Temperature.
2. Auto Mode: The Home Screen displays the Process Setpoint and the Process Temperature.

### Quick Setpoint Adjust (auto mode only)

This feature allows some Process Setpoints to be adjusted as a group even when the system is running. Affected setpoints are the Low Fire Setpoint (if enabled), the Process Setpoint, and the Pilot Off Setpoint (if enabled). These Process Setpoints can be adjusted directly from the Home Screen using the Up and Down Keys. The adjustments are limited by the maximum ranges of the Process Setpoints. Any changes made take effect immediately. This feature is protected by the L1 Password when password protection is enabled in Menu 4.

### Review Menu (manual mode only)

The Review Menu is a diagnostic menu used to check key setpoints and view real time system measurements such as temperature, pressure, and level. To access it, press the Up or Down Key while on the Home Screen.

### System Menus

Menus 1, 4, 5, and 6 are used for checking and adjusting settings. Menus 2 and 3 show diagnostic values. Menu 7 is used for calibration and is hidden by default. The System Menus are accessed by pressing the Menu Key from the Home Screen while in Manual Mode. Some menus are not accessible while the system is running. Menu 3 contains some system status information not found elsewhere in the menu system. Refer to the Menu Map table for more details.

When the system is stopped, all settings can be checked and adjusted. When the system is running, only some settings may be checked or adjusted. The following table illustrates the circumstances under which various settings can be checked and adjusted. For more information about the menu system and the user interface, see the [Menu Map](#) section.





MODE	HOME SCREEN	QUICK SETPOINT CHANGE AVAILABLE	REVIEW MENU AVAILABLE	SYSTEM MENUS AVAILABLE
Manual Mode, System Stopped	System State Process Temperature	No	Yes	1-6 (and sometimes 7)
Manual Mode, System Running	System State Process Temperature	No	Yes	1-3
Auto Mode, System Running	Process Setpoint Process Temperature	Yes	No	None

## DIAGNOSTIC OPTIONS

### Viewing Event Counters

Menu 2 contains a series of counters that increment automatically in response to various events. These counters can be used to troubleshoot issues with a particular installation. Each counter will count to a maximum of 1000 and then will stop incrementing. At the bottom of Menu 2 is an option to clear these counters. Clearing the counters also clears the event log.

- ESDs: Increments each time the system shuts down as a result of the ESD Contact opening, the High Temp ESD Setpoint being exceeded by either Process Temp or Aux Temp (if enabled), or a high or low voltage alarm.
- Flame Fails: Increments each time the system shuts down as a result of failing to ignite the pilot within the allocated number of retries.
- High Pressure ESDs: Increments each time the system shuts down as a result of the High Pressure Contact opening or the 4-20 Pressure reading exceeding the 4-20 High Pressure Setpoint.
- Level ESDs: Increments each time the system shuts down as a result of the Level Contact opening or the 4-20 Level reading dropping below the 4-20 Low Level Setpoint.
- Low Pressure ESDs: Increments each time the system shuts down as a result of the Low Pressure Contact opening or the 4-20 Pressure reading dropping below the 4-20 Low Pressure Setpoint.
- Thermocouple Errors: Increments each time the system shuts down as a result of a thermocouple issue such as a short circuit, open circuit, or ground short.
- Relights: Increments each time the system attempts to automatically re-ignite the pilot. The first ignition attempt after a manual start is not counted.
- Resets: Increments each time the door card is reset by a power loss or by manually pressing the reset button.
- System Errors: Increments each time the system shuts down as a result of an internal system error.
- Terminal Card Errors: Increments each time the system shuts down as a result of a terminal card error.

### Viewing the Event Log

The Event Log can be accessed from the end of Menu 2. The log contains entries for various types of events such as System Starts, Stops, Shutdowns, Menu Accesses, etc. The log holds a maximum of 32 events. The first event (#1) is the most recent and the last event

(#32) is the oldest.

When the log is full, the oldest event is removed from the list to make room for the next newest event. Navigate through the log using the up and down arrow keys. Press OK to return to the Home Screen. The log can be cleared using the item at the end of Menu 2. Clearing the log also resets all event counters to zero.

The following is an alphabetical list of all possible Event Log entries including a brief description of their meaning and the associated counter which will increment when that event occurs:

ENTRY	DESCRIPTION	ASSOCIATED COUNTER
AUTO	The system switched to Auto Mode because the user pressed the MODE and OK button.	
AUX ESD	The "Aux Temp Mode" setting is set to "Temp ESD" and the Aux Temp signal exceeded the "Aux Setpoint".	ESDs
ESD	The system shut down as a result of the ESD contact being open.	ESDs
FLAME FAIL	The pilot went out and could not be relit automatically within the specified number of attempts (3 attempts on initial start; user defined for other cases).	Flame Fails
HI PRS ESD	The system shut down because the High Pressure Contact was opened or the "4-20mA High Pressure Setpoint" was exceeded.	High Pressure ESDs
HI VOLT	The system input voltage exceeded the High Voltage Alarm threshold.	ESDs
HT ESD	The "High Temp ESD Setpoint" was exceeded by either "Proc Temp" or "Aux Temp" (if enabled) and caused the system to shutdown.	ESDs
LEVEL ESD	The system shut down because the Level Contact was opened or the "4-20mA Low Level Setpoint" was dropped below.	Level ESDs
LO PRS ESD	The system shut down because the Low Pressure Contact was opened or the "4-20mA Low Pressure Setpoint" was dropped below.	Low Pressure ESDs
LO VOLT	The system input voltage dropped below the Low Voltage Alarm threshold.	ESDs
LOW ALARM	The "Proc Temp" signal dropped below the "Low Temp Alarm Setpoint".	
MANUAL	The system switched to Manual Mode because the user pressed the MODE button.	
MENU:CTL	Menu 5 "Control" was entered. This will show even if no settings are modified.	
MENU:SETPT	Menu 1 "Setpoints" was entered. This will show even if no settings are modified.	
MENU:SYS	Menu 4 "System" was entered. This will show even if no settings are modified.	
POC STOP	The "Proof of Closure Contact" was open when it should not have been causing the system to shutdown.	
RELIGHT	The pilot was successfully relit after it went out unexpectedly.	Relights
RESET	The system was reset due to a loss of power or a manual press of the Door Card's reset button.	Resets
RETRY	The Pilot failed to light and one or more retry attempts were made.	
RUNNING	The system successfully lit the pilot.	
START	The system switched to Auto mode at a point in time when the pilot was not lit.	
STOPPED	The system stopped because the user pressed the STOP button while the Pilot Valve was open.	
SYSTEM ERR	An internal system error has occurred.	System Errors
TCERR:AUX	The AUX Thermocouple is out of range.	Thermocouple Errors
TCERR:HT	The High Temp Thermocouple is out of range or grounded.	Thermocouple Errors
TCERR:PROC	The Process Thermocouple is out of range.	Thermocouple Errors



ENTRY	DESCRIPTION	ASSOCIATED COUNTER
TC NOT EQ	The system detected an unacceptable difference between the Process and High Temp Thermocouple readings. The acceptable difference varies with the HT ESD Setpoint (ESD) as follows: 15C when ESD < 200C 25C when 200C <= ESD < 400C 35C when 400C <= ESD < 800C 45C when 800C <= ESD	
TERM ERR	Communications between the Terminal Card and the Door Card has been interrupted.	Terminal Card Errors

### Viewing Firmware Versions

From anywhere in the User Interface, press the Up and Down Keys simultaneously. The system will show four different firmware versions in sequence:

CARD	CURRENT FW VERSION	NOTE
Door Card	DC FW: E1.8.217	
Terminal Card	TC FW: E1.8.217	
4-20mA Repeater Expansion Card	4-20 FW: v4.4	Will show “—” if not installed or not enabled in Menu 6
Modbus Expansion Card	MBUS FW: v4.4	Will show “—” if not installed or not enabled in Menu 6

## 4 | SYSTEM BEHAVIOR

This section of the manual describes the behavior of the PF2100 when various features are enabled vs disabled. Simplified state diagrams are provided and discussed to give a high level understanding of how the system works.

### 4.1 | System Behavior

The following diagrams illustrate the behavior of the PF2100 during common system events. Note that when the PF2100 changes states while in Auto mode, the new state will be shown momentarily on the display. In Manual Mode, the current state is always shown on the display.

#### SYSTEM START UP

When the system is powered on, the start up sequence is as follows:

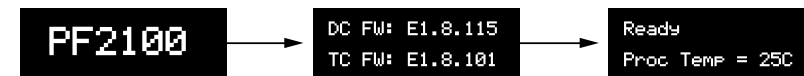

1. PF2100 displayed in large text
2. Firmware versions of the Door and Terminal Card
3. The Home Screen showing the system state. The system state will be “Ready” if no alarms are present. Otherwise, the state will be “Alarm.”

#### STARTING IN AUTO MODE

When the system is started in Auto Mode (by pressing the Mode and OK Keys), it will run through the ignition sequence automatically. In Auto Mode, the PF2100 will automatically attempt to relight the pilot if it ever goes out unexpectedly.

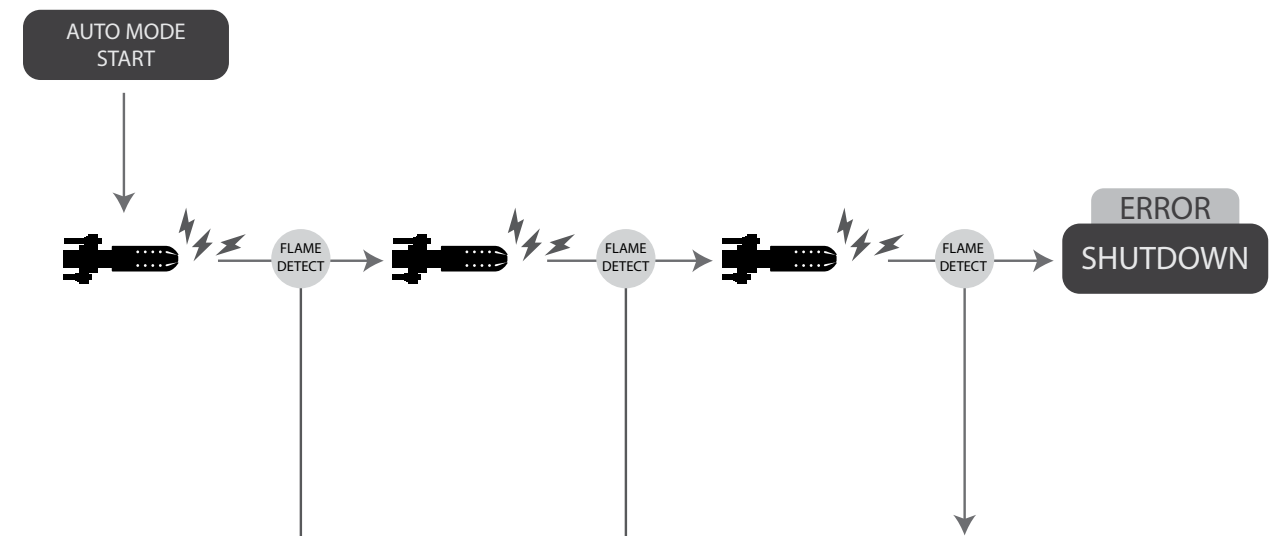

The [Process Control](#) sequence will be explained in more detail later.

## STARTING IN MANUAL MODE

When the system is started in Manual Mode (using the Pilot, Ignite, and Main Keys), it must be manually moved through the ignition sequence. In Manual Mode, the PF2100 will NOT automatically attempt to relight the pilot if it ever goes out unexpectedly. It will only attempt to relight the pilot if it was turned off by the system as a result of normal process control (ie, Waiting on Temp, Waiting for Level, etc).

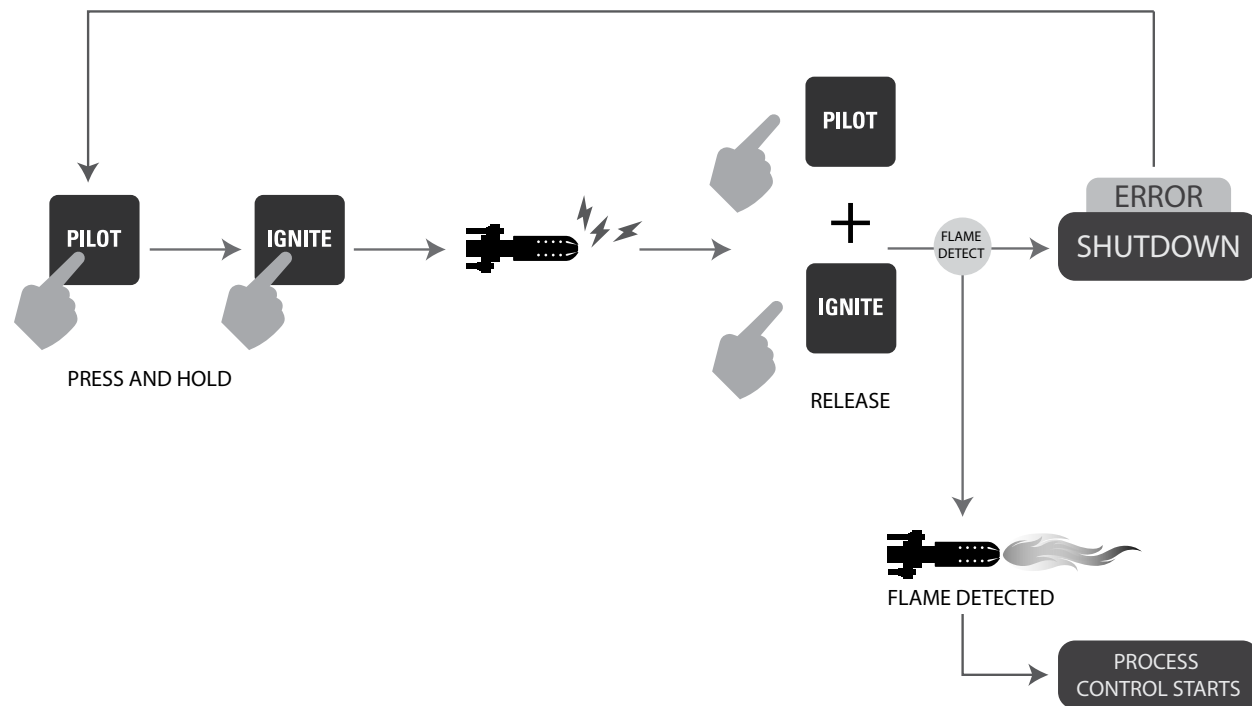

The [Process Control](#) sequence will be explained in more detail later.

## 4.2 | Process Control

The PF2100 maintains a process at a user specified temperature. The system monitors the temperature and adjusts to increase or decrease the temperature as needed. This is an automated sequence of events based on user settings. This process of monitoring and controlling is called Process Control. The system uses a gas fired heater with an electronic ignition circuit and several electronic fuel valves (also called solenoids). It also has a flame detection circuit and up to three temperature measuring thermocouples.

The PF2100 has three inputs: High Temp, Proc Temp, and Aux Temp. By default, these signals correspond to the High Temp Thermocouple, the Process Thermocouple, and the Aux Thermocouple respectively. The Process Control setting allows the Process and Aux thermocouples to be swapped. This is useful in circumstances that will be explained later.

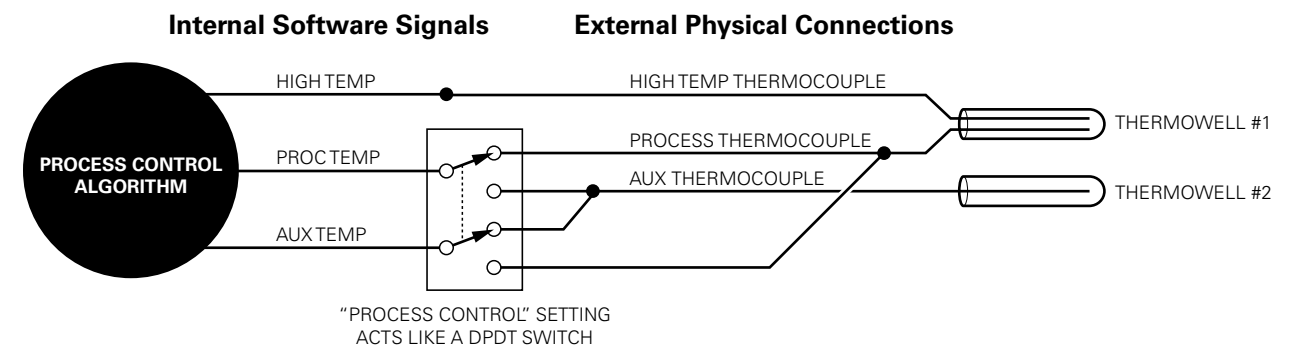

It is expected that the High Temp Thermocouple and the Process Thermocouple will always be mounted in a common thermowell. This is usually accomplished by using a duel element thermocouple. The software uses these two thermocouples as a check for each other as a failsafe. If the readings from these two thermocouples do not agree within a specified amount of error, the system will shut down.

The High Temp signal is used to protect the burner and other process equipment from being damaged due to excessive heat. It cannot be disabled through any combination of process control settings.

The Proc Temp signal is the primary control signal for Process Control. This signal is compared to the Deadband, Low Temp Alarm Setpoint, Process Setpoint, Low Fire Setpoint, and the Pilot Off Setpoints in order to control the temperature of the process.

The Aux Temp signal can be used as a secondary control signal. The way that this signal is used will vary depending on the Aux Temp Mode setting. If enabled, an Aux Setpoint gets compared to this signal.

### STANDARD PROCESS CONTROL

Using very basic settings, the PF2100 behaves as follows.

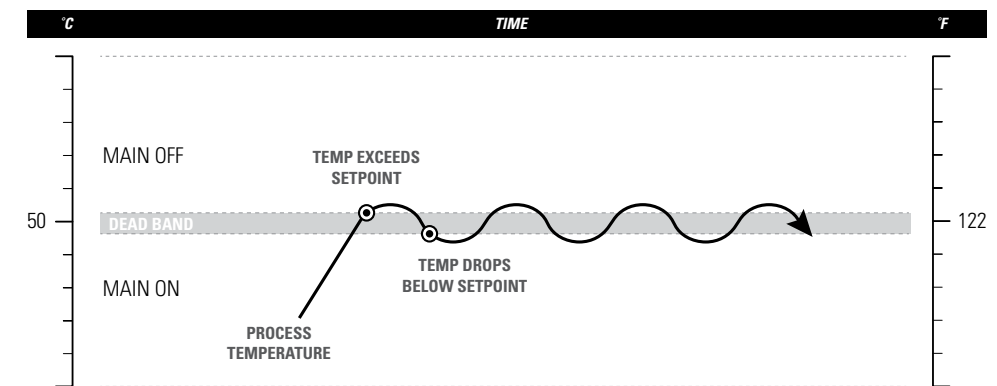

1. The Main Valve opens and the Process Temperature increases.
2. The Process Temperature exceeds Process Setpoint, the Main Valve closes, and the Process Temperature begins to drop.
3. The Process Temperature drops below the Process Setpoint minus Deadband, the Main Valve opens, and the Process Temperature begins to increase again.

### LOW FIRE: ON AT PROC SETPOINT

This example has the Process (High Fire) and Low Fire Setpoints enabled. It has been set to turn on at the Process Setpoint. This example uses two valves, a Low Fire valve and a High Fire valve. Both valves start open in this example.

The system behaves the same as in the [standard process control](#) diagram until the demand for heat drops.

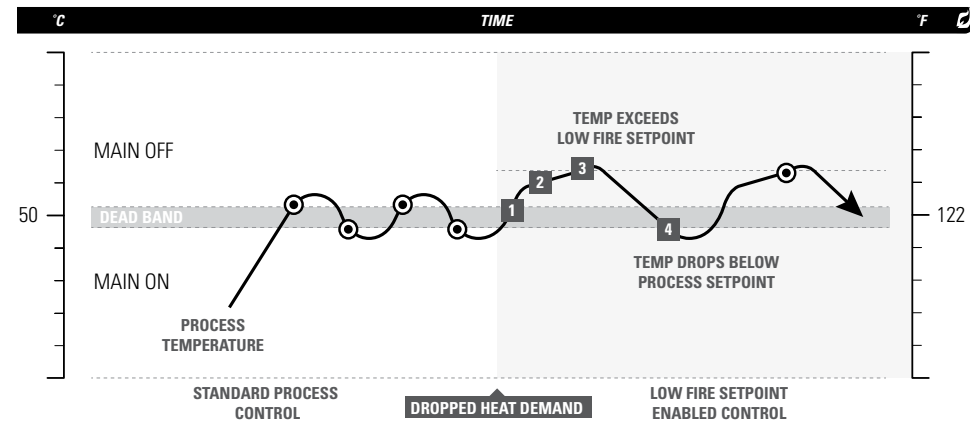

1. The Process Temperature reaches the Process Setpoint and the main valve closes.
2. The Process Temperature continues to rise.
3. The Process Temperature exceeds the Low Fire Setpoint, the Low Fire Valve closes, and the Process Temperature drops.
4. The Process Temperature drops below the Process Setpoint minus the Deadband, the High Fire Valve opens, and the Process Temperature begins to increase again.

### PROPORTIONAL VALVE CONTROL

The Low Fire: On Proc Setpoint can be used in conjunction with a proportional valve connected to the 4-20mA Output. In this mode, the PID Controller adjusts the proportional valve and attempts to fix the temperature at the Process Setpoint.

### LOW FIRE: ON AT LOW FIRE SETPOINT

This example has the Low Fire feature enabled and set to "On at Low Fire Setpoint." In this case, the Low Fire Valve will close when it exceeds the Low Fire Setpoint, and will reopen after it drops below the Low Fire Setpoint minus Deadband.

The system behaves the same as in the [standard process control](#) diagram until the demand for heat drops.

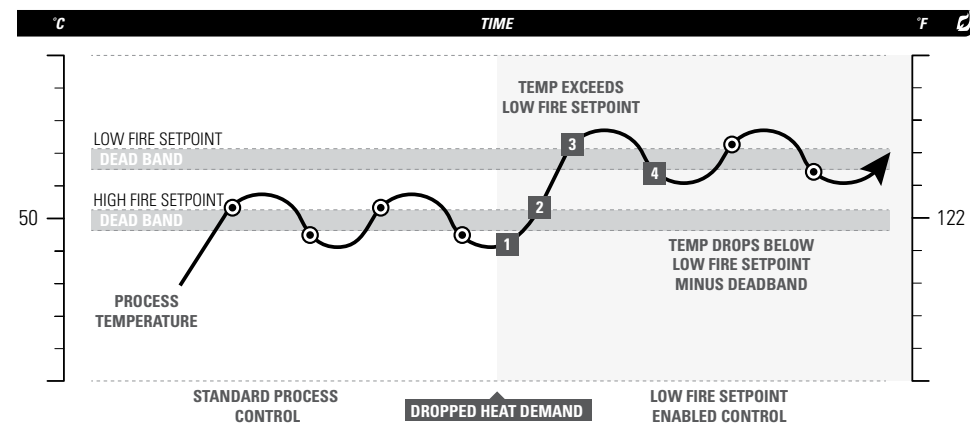

1. The Process Temperature continues to rise.
2. The Process Temperature exceeds the High Fire Setpoint, the High Fire Valve closes, and the Process Temperature continues to rise.
3. The Process Temperature exceeds the Low Fire Setpoint, the Low Fire Valve closes, and the Process Temperature drops.
4. The Process Temperature drops below the Low Fire Setpoint minus Deadband, the Low Fire Valve opens, and the Process Temperature begins to rise again.

### PILOT OFF

This scenario is the same as the basic scenario except that the Pilot Off feature has now been enabled. In this case, when the Proc Temp rises above the Pilot Off Setpoint the Pilot Valve will close and will not re-light until the temperature is below the Process Setpoint minus Deadband.

The system behaves the same as in the [standard process control](#) diagram with the added ability to shut off the pilot as needed.

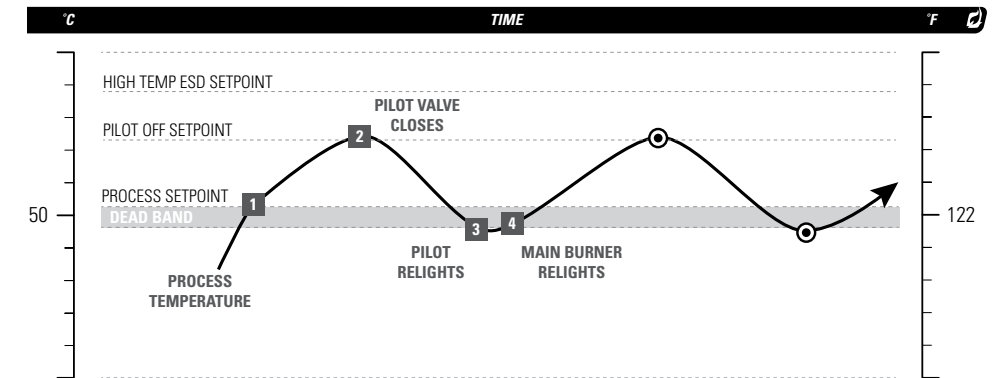

1. The temperature exceeds the Proc Setpoint and the Main Valve closes.
2. The temperature continues to rise and the Proc Temp exceeds the Pilot Off Setpoint, the Pilot Valve closes, and the Proc Temp begins to decrease.
3. The Proc Temp drops below the Process Setpoint minus Deadband, the pilot relights, and the Proc Temp begins to increase again.
4. The Pilot-to-Main Delay elapses, the Main Valve opens, and the Proc Temp begins to increase faster.

### HIGH TEMP ESD

The High Temp ESD Setpoint is always compared against the High Temp Thermocouple regardless of the Process Control setting. The system will immediately shut down if this thermocouple exceeds this setpoint. Because the High Temp Thermocouple and Process Thermocouple must always be in the same thermowell, these two thermocouples can be thought of as being the same. Note that the internal signal to which the Process Thermocouple is associated (Proc Temp or Aux Temp) will change depending on the Process Control setting.

This particular graph is a representation of a high temperature shutdown. Once the Process Temperature exceeds the High Temp ESD Setpoint, the system will shut down and require user input to acknowledge the error.

The system behaves the same as in the [standard process control](#) diagram until the demand for heat drops.

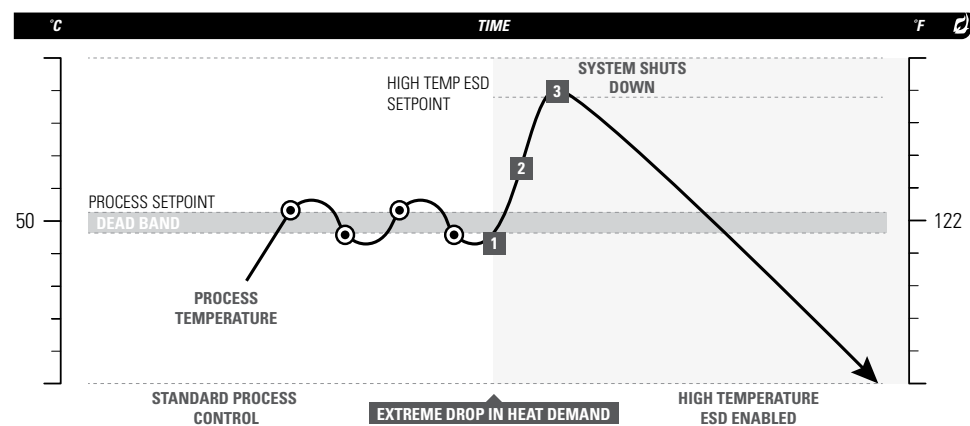

1. Heat demand suddenly and substantially decreases. This could be caused by a rapid decrease in flow by the line heater or a sudden emptying of a tank heater.
2. The Process Temp rises sharply.
3. The High Temp Thermocouple temperature rises above the High Temp ESD Setpoint, the system immediately shuts down, and the High Temp Thermocouple temperature begins to decrease slowly.

#### AUX TEMP MODE: TEMP MAIN CTL

When Aux Temp Mode is set to Temp Main Ctl, it enables the Auxiliary Temperature input. The Proc Temp signal measures the outlet temperature of a line heater and the Aux Temp signal measures the bath temperature. If the heat demand increases, the bath temperature may rise quickly. The Aux Setpoint is used to shut off the Main Valves to protect the bath and fire tube in the event of excessive bath temperature.

#### AUX TEMP MODE: TEMP ESD

If the Aux Temp Mode is set to Temp ESD, then the Aux Temp signal must be below the Aux Setpoint or the system will shut down. Normally this happens independent of the High Temp ESD previously described. However, it is possible for the High Temp ESD Setpoint and the Aux ESD Setpoint to both be applied to the same thermocouple. This happens when Process Control is set to Aux TC and Aux Temp Mode is set to Temp ESD. In this case, whichever setpoint is lower will be used.

In this mode, the Aux Setpoint is used as another ESD setpoint. It is always compared against the Auxiliary Temperature signal which depends on the Process Control setting. The system will immediately shut down if this signal exceeds this setpoint.

#### AUTOMATIC RESTART EVENTS

In all waiting states, the system turns off the burner and pilot and waits for some event to occur before restarting. There are two other groups of waiting states which may be optionally enabled: Auto Restart

and Level Event Restart. Each of these states can be entered automatically from any other Process Control state if the associated condition is satisfied.

Several waiting states are enabled when the Auto Restart feature is enabled. The conditions and the triggering states are as follows:

- Waiting on Low Voltage- System Voltage below Low Alarm
- Waiting on High Voltage- System Voltage above High Alarm,
- Waiting on Low Pressure- Low Pressure Contact open or 4-20mA Pressure below Setpoint

One waiting state is enabled when the Level Event Restart feature is enabled:

- Waiting on Low Level- Level Contact Open or 4-20mA Level below Low Setpoint

Once the triggering condition is cleared, the system will automatically restart via the Relight procedure.

#### RELIGHT PROCEDURE

After the system has been initially started, if it needs to be automatically relit, the system responds based on the reason the pilot is off. If the event is a controlled one, the PF2100 follows the Process Control sequence using the system settings. If the pilot goes out unexpectedly, the PF2100 checks to see which mode it is in. In Manual mode, the system goes straight to shutdown; in Auto mode, the system goes through [Auto Mode Start Up](#). Note that the number of retries varies depending on the reason for pilot being off, three for Process Control, none for Manual mode, and the user defined amount in Auto mode.

## 4.3 | Contact Behavior

This section discusses the behavior of the PF2100's input and output contacts and its response to external signals.

#### STATUS OUTPUT

The Status Output Contact is generally used to remotely determine whether the system is operating normally. It can be connected to a PLC and used to trigger a remote alarm so that a service technician can be sent to the site in the event of trouble.

In general, the contact will be closed when the system is running and it will be open when the system is not running. Five exceptions to this are as follows:

1. On Start: When the system is first started, the status contact will remain open until after the pilot has been successfully lit.
2. Alarm Mode: If the Alarm Mode setting in menu 4 is No Alarm When Off, the contact will remain closed if the system is stopped because the Start Contact is open.
3. Low Temp Alarm: If the Low Temp Alarm feature is enabled in menu 1 and the Process Temperature is currently below the Low Temp Alarm Setpoint, the Status Contact will be open. The contact will close again as soon as the temperature rises above the Low Temp Alarm Setpoint.

4. While Waiting: If the system is in a waiting state, the status contact will remain closed.
5. While Restarting: If the flame blows out and the system is in the process of relighting the pilot, the status contact will remain closed. If the pilot fails to relight within the specified number of relight attempts, then the contact will open.

### START INPUT

The Start Input Contact is used to remotely stop and start the PF2100. This can be done by connecting it to an output relay on a PLC or to a switch located elsewhere on the site. Generally speaking, the system will begin running when the contact is closed and will stop running when the contact is open. The exception to this is when the system shuts down as a result of an alarm condition. In this case, the contact must be closed to acknowledge the shutdown condition and must then be opened and closed again to restart the system. The status contact can give some idea as to whether the system is shutdown. However, it is not always possible to do so, so it is recommended to always start the system using the close-open-close sequence described above. This will always work even if the system is not waiting for a shutdown message to be acknowledged. Once the start sequence has been entered, the system will start after the purge time has elapsed. When the start contact is opened, the system will always stop immediately.

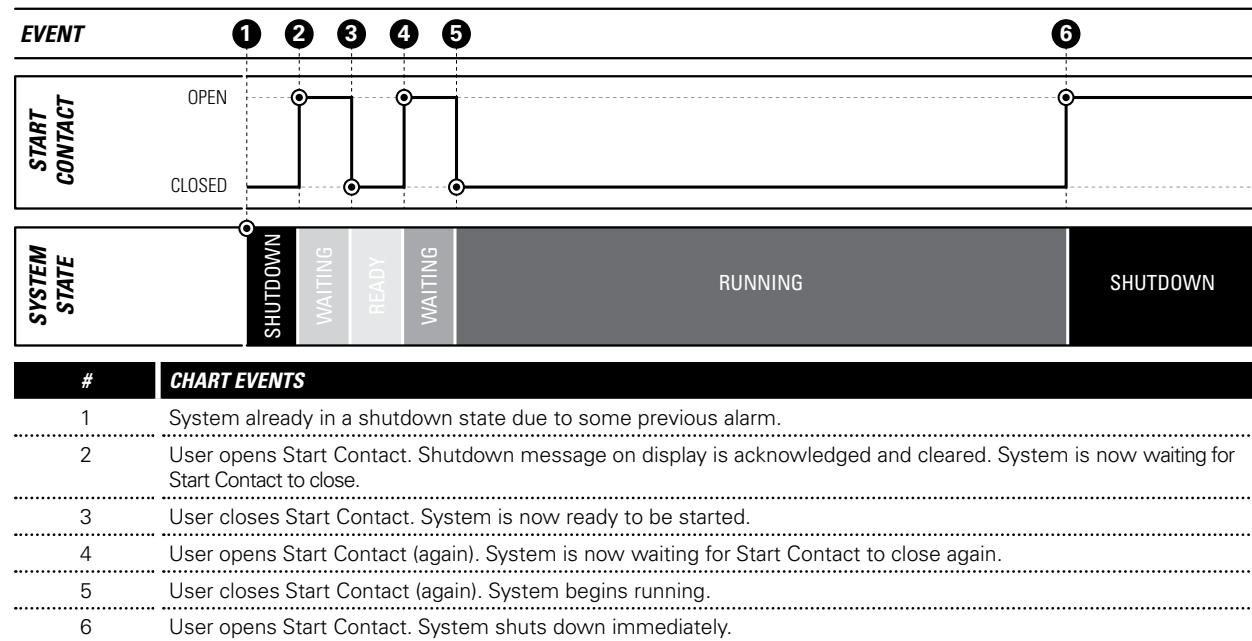

If this contact is not needed, it must be shorted out with the provided jumper or a wire.

### ESD INPUT

The ESD Input Contact is used to stop the PF2100 in the event of an emergency. This is normally done by connecting the contact to the site's ESD Loop. The PF2100 will shutdown immediately when the contact is opened and cannot be restarted until the contact is closed. The PF2100 will not restart automatically if the ESD contact is subsequently reclosed but must instead be restarted via the start contact, the keypad, or the Modbus card (if installed).

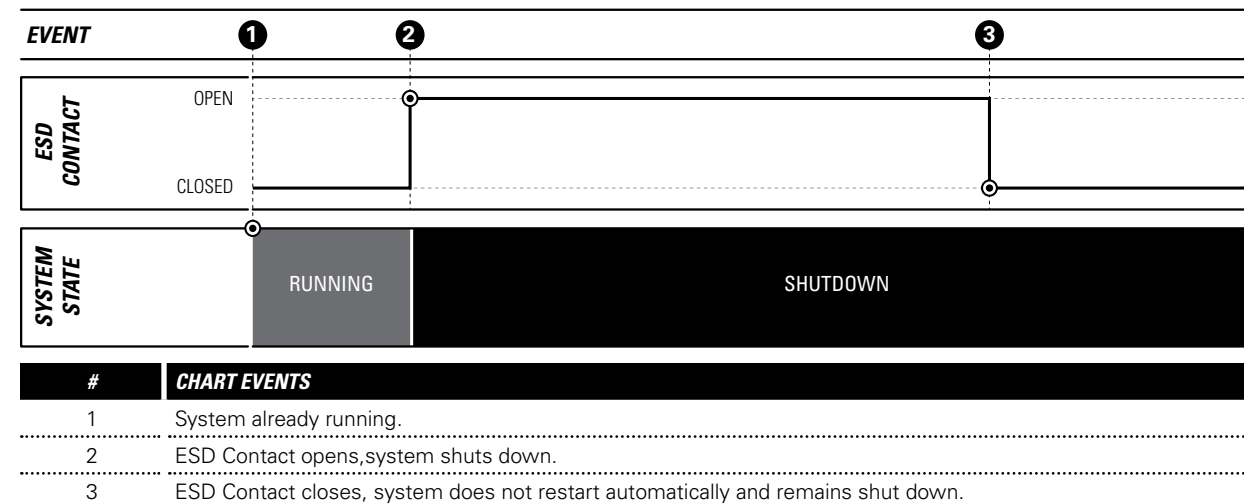

If this contact is not needed, it must be shorted out with the provided jumper or a wire.

### PROOF OF CLOSURE INPUT

When the PF2100 is started, it drives the Main Valves to the closed position. If, for some reason, the valves do not close, a dangerous situation can result. This condition might arise if a valve is mechanically damaged, frozen open, or has been wired incorrectly. If undetected, the PF2100 may attempt to light the burner while a dangerous amount of gas is present resulting in an explosion. To prevent this, the Proof of Closure Input Contact can be used to monitor the mechanical position of the Main Valves. This feature requires the use of valves that have a built-in Proof of Closure output. If more than one Main Valve is used, the Proof of Closure outputs from each valve are wired together in series before being connected to the PF2100's Proof of Closure input.

The Proof of Closure contact must be closed in order for the Purge Timer to count down. If it is ever opened while the system is not running, the Purge Timer is reset and must count down again before the system can be started. In short, the Proof of Closure contact must be closed for the entire duration of the Purge Time or the system will not start. While running, if the Proof of Closure contact ever opens when it is not expected to be open, the system will shut down after 7 seconds.

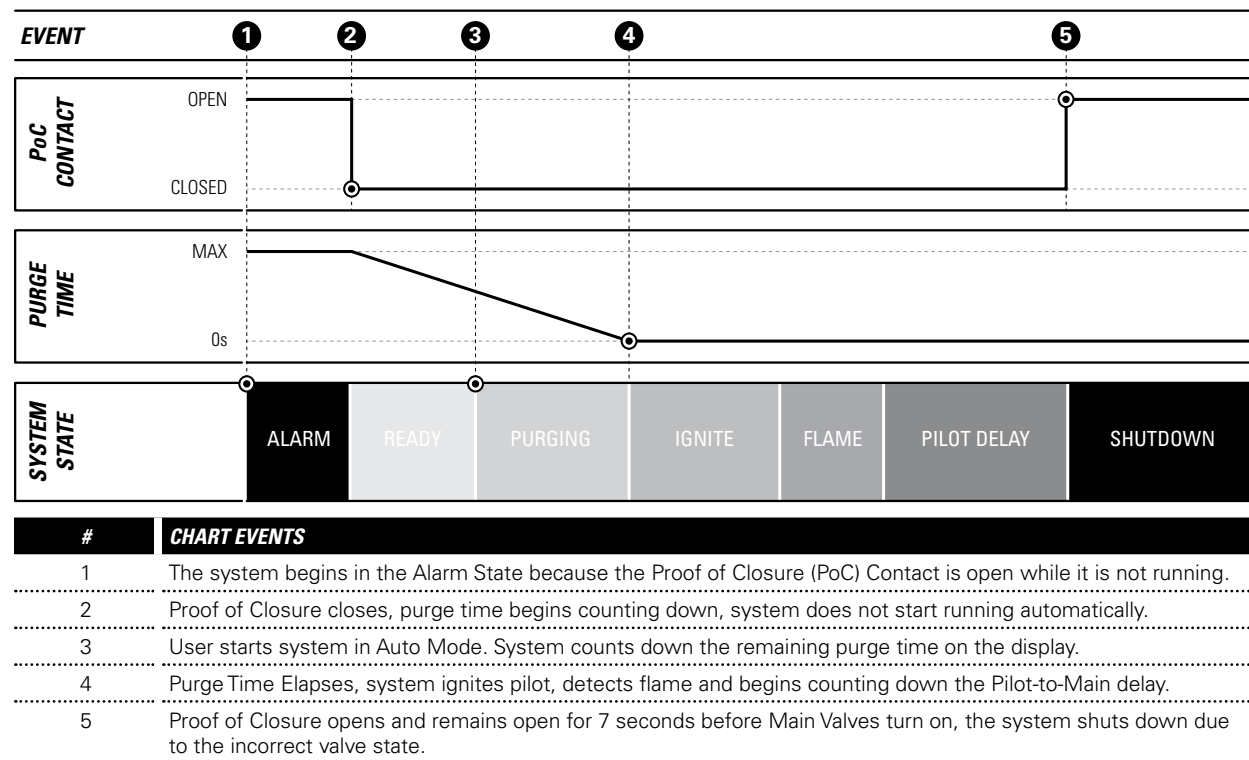

If this contact is not needed, it must be shorted out with the provided jumper or a wire.

### LEVEL INPUT

The Level Input is generally used in tank heater applications. A level switch is installed in the tank to determine when the tank fluid level drops below to position of the fire tube. This switch is then connected to the Level Input Contact on the PF2100. If the fluid level drops below the switch position, the switch opens and the PF2100 will stop heating the tank. This is to prevent damage to the tank and fire tube which may result from applying heat to the empty tank. Generally, this situation arises when a tanker truck arrives on site and empties the tank into the truck. The system can be setup to begin heating the tank again automatically after the level of fluid rises back above the switch position. This is done by enabling the "Level Event Restart" setting in menu 4.

The response to the contact opening is delayed by 2s to reject electrical noise that is common on some sites. If long periods of severe noise are common on a particular site, the delay can be increased to 20s by enabling the "Pressure/Level Delay" feature in menu 4.

If this contact is not needed, it must be shorted out with the provided jumper or a wire.

Chart 1: Level Event Restart = Disabled

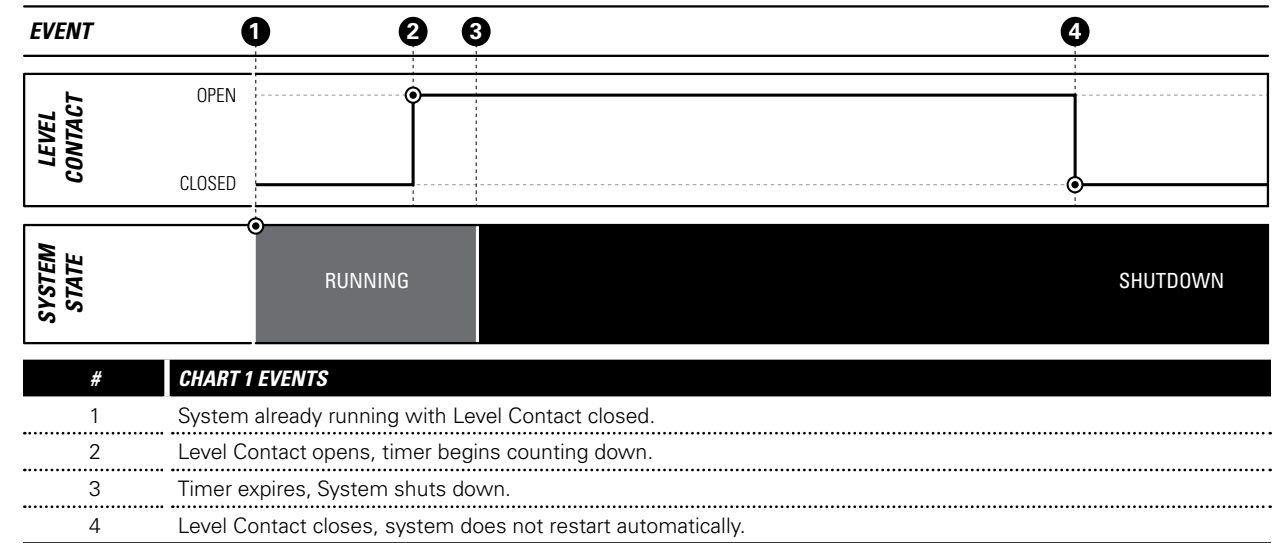
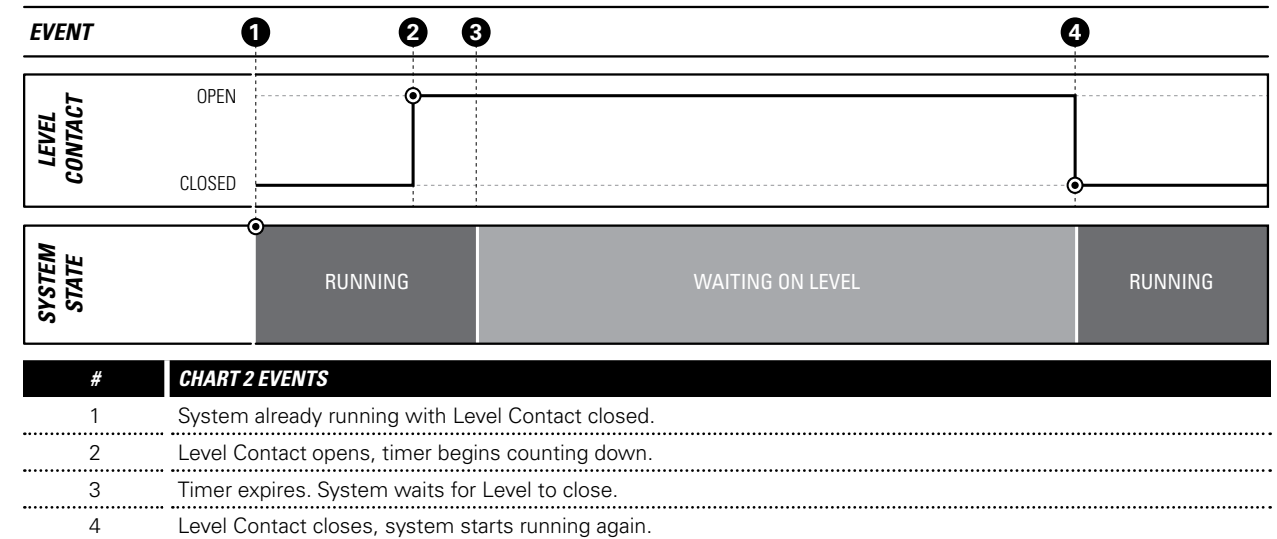

Chart 2: Level Event Restart = Enabled



### LOW PRESSURE INPUT

The Low Pressure Input is used to monitor fuel train pressure. Insufficient fuel pressure may result in the flame burning back into the fuel train causing damage or improper operation. A low pressure switch can be installed on the fuel train and then connected to the Low Pressure Input Contact on the PF2100. If the fuel pressure drops below the switch's mechanically set pressure setting, the switch opens and the PF2100 will close all valves and stop running. The system can be setup to begin running again automatically after the pressure returns above the switch's pressure setting. This is done by enabling the Auto Restart feature in menu 4.

The response to the contact opening is delayed by 2s to reject electrical noise that is common on some sites. If long periods of severe noise are common on a particular site, the delay can be increased to 6s by enabling the "Pressure/Level Delay" feature in menu 4.

If this contact is not needed, it must be shorted out with the provided jumper or a wire.

Chart 1: Low Pressure Restart=Disabled

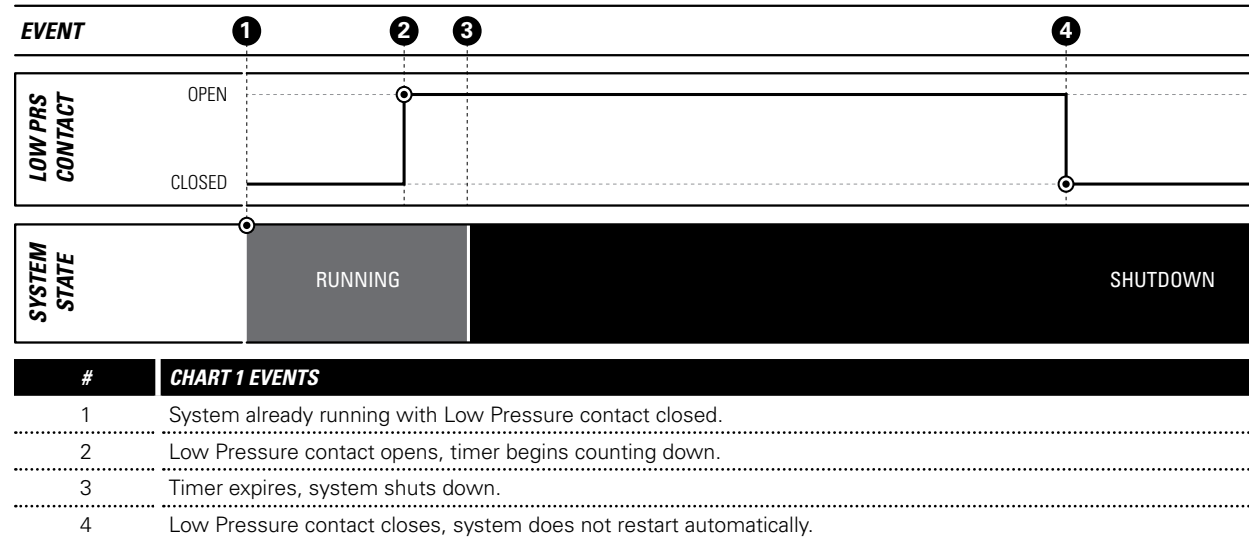
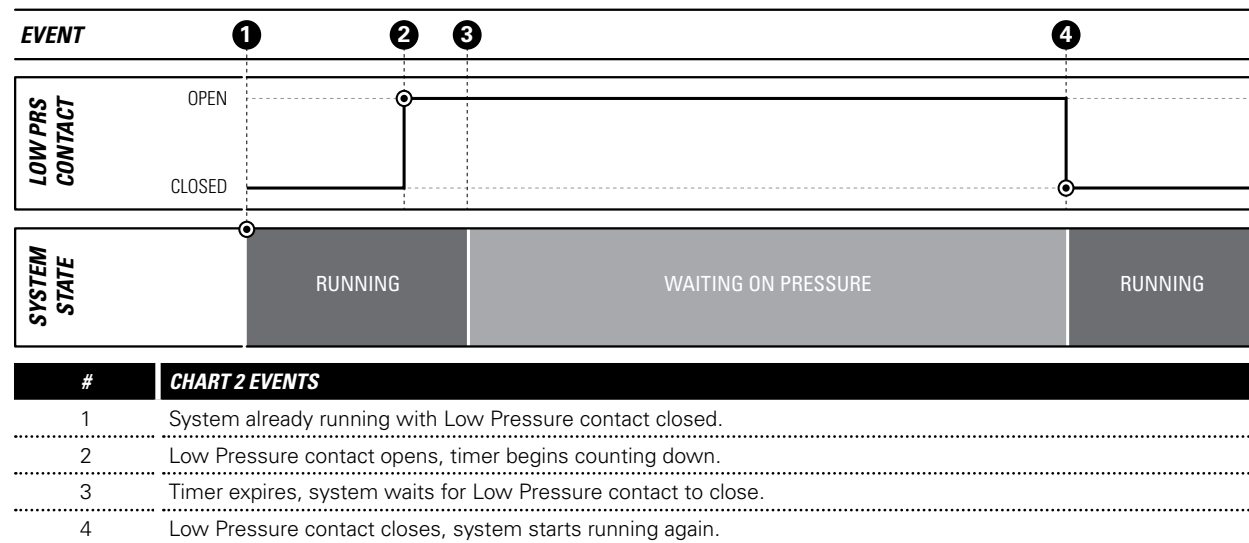

Chart 2: Low Pressure Restart=Enabled



### HIGH PRESSURE INPUT

The High Pressure Input Contact is used to monitor fuel train pressure when excess fuel pressure may result in damage to the pilot nozzle or otherwise cause improper operation. A high pressure switch can be installed on the fuel train and then connected to the High Pressure Input Contact on the PF2100. If the fuel pressure increases above the switch's mechanically set pressure setting, the switch opens and the PF2100 will close all valves and stop running. The system always shuts down from a High Pressure Event and cannot be programmed to automatically restart if the event clears.

The system cannot be started when the High Pressure Contact is open. The response to the contact opening is always immediate and cannot be configured.

If this contact is not needed, it must be shorted out with the provided jumper or a wire.

## 5 | EXPANSION CARDS

### 5.1 | 4-20mA Repeater Expansion Card

An optional 4-20mA Repeater Expansion Card can be installed in the PF2100 which provides 4-20mA inputs for level and pressure, 2 dry level contacts and a 4-20mA output which mirrors the input 4-20mA level signal.

#### 4-20MA FUEL TRAIN PRESSURE MEASUREMENT

This card can be used as an alternative to the High and Low Pressure Contacts which are built into the PF2100. This input can be wired to a 4-20mA Pressure Transmitter to obtain an actual reading of the fuel train pressure. The transmitter range and units can be set along with low and high pressure thresholds. The reading can be displayed on the PF2100 display or read remotely via Modbus if either the optional Modbus Expansion Card or the Data logging Expansion Card is also installed.

#### 4-20MA TANK LEVEL MEASUREMENT

This can be used as an alternative to the Level Contact which is built into the PF2100. This input can be wired to a 4-20mA Level Transmitter to obtain an actual reading of the tank level. The transmitter range and units can be set along with low and high level thresholds. The reading can be displayed on the PF2100 display or read remotely via Modbus if either the optional Modbus Expansion Card or the Data Logging Expansion Card is also installed.

#### TANK HIGH LEVEL DRY CONTACTS

Both Normally Open (NO) and Normally Closed (NC) contacts are provided. When the Level reading is above the High Level Setpoint, the NO contact will close and the NC contact will open. The opposite is true whenever the Level reading is below the High Level Setpoint. This can be used to control auxiliary equipment such as a warning light, an alarm, or the pump that is filling the tank.

Refer to the "4-20mA Repeater Expansion Card Manual" for details on installation and operation of this card.

#### 4-20MA LEVEL OUTPUT

This output can be wired to a PLC to monitor tank level remotely. The output echoes the signal applied to the 4-20mA level input contacts.

If the 4-20mA level output is not required, it must be shorted out with the provided jumper or a wire.



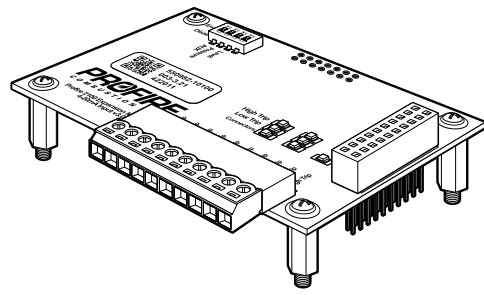

#### 4-20MA REPEATER EXPANSION CARD

Some PF2100 models come with this card pre-installed.

#### 4-20MA REPEATER EXPANSION CARD SETTINGS

These settings all apply to the 4-20mA Repeater Expansion Card which must be installed in the PF2100's expansion slot. These settings can all be found in Menu 6. Some of these settings will be hidden if the card is not installed or enabled.

#### 4-20 REPEATER EXPANSION CARD ENABLE (MENU 6)

For the Tank Level Settings to be visible, the LVL DIP Switch on the 4-20mA Repeater Card must be enabled.

##### Tank Level Settings:

1. 4-20 LEVEL ZERO OFFSET (menu 6): Specifies the offset value for the tank's level transmitter.
2. 4-20 LOW LEVEL SETPOINT (menu 6): If the 4-20mA LVL input drops below this setpoint, the burner will turn off to prevent damage to the tank and fire tube.
3. 4-20 HIGH LEVEL SETPOINT (menu 6): If the 4-20mA LVL input exceeds this setpoint, the LVL output contacts on the 4-20mA Input Card will toggle.
4. 4-20 LEVEL RANGE (menu 6): Specifies the maximum capacity of the tank's 4-20mA level transmitter.
5. 4-20 LEVEL UNITS (menu 6): Specifies the units of measurement. Note that this may have an impact on measurement accuracy.

##### Fuel Train Pressure Settings

For the Fuel Train Pressure Settings to be visible, the PRS DIP Switch on the 4-20mA Input Card must be enabled.

1. 4-20 LOW PRESSURE SETPOINT (menu 6): If the 4-20mA PRS input drops below this setpoint, the burner will turn off to prevent flame from burning back into the fuel train.
2. 4-20 HIGH PRESSURE SETPOINT (menu 6): If the 4-20mA PRS input exceeds this setpoint, the system will shut down.
3. 4-20 PRESSURE RANGE (menu 6): Specifies the maximum capacity of the tank's 4-20mA Pressure transmitter.
4. 4-20 PRESSURE UNITS (menu 6): Specifies the units of measurement. Note that this may have an impact on measurement accuracy.

#### 4-20MA LEVEL INPUT & OUTPUT CONTACTS

The 4-20mA Level Input is used to monitor tank level in the same way as the Level Contact. The behavior and features are identical to those described in the previous [Contact Behavior](#) section. The difference is that a Level Transmitter is used instead of a Level Switch and the Low Level setpoint is set via a menu instead of the physical position of the switch on the tank. When the 4-20mA signal is below the Low Level setpoint, the system will stop. When it is above the setpoint, the system will run.

The 4-20mA Expansion Card also has a pair of High Level Output Contacts which toggle when the Level Input exceeds the Level High Setpoint. One contact is normally open and the other is normally closed. "Normally," in this case, means "when the level is below the high setpoint." The normally closed contact could be used to turn off the pump that is filling the tank and the normally open contact could be used to sound a remote alarm to signal that the tank is full.

#### To use the 4-20mA Level Input, it must be setup as follows:

1. Attach a properly calibrated Level Transmitter to the 4-20 Level Input
2. Enable the Level DIP Switch on the 4-20 Card
3. Enable the 4-20 Card in menu 6
4. Set the Level Low Setpoint, High Setpoint, Range, and Units in menu 6
5. Disable the Level Contact by installing a jumper in it



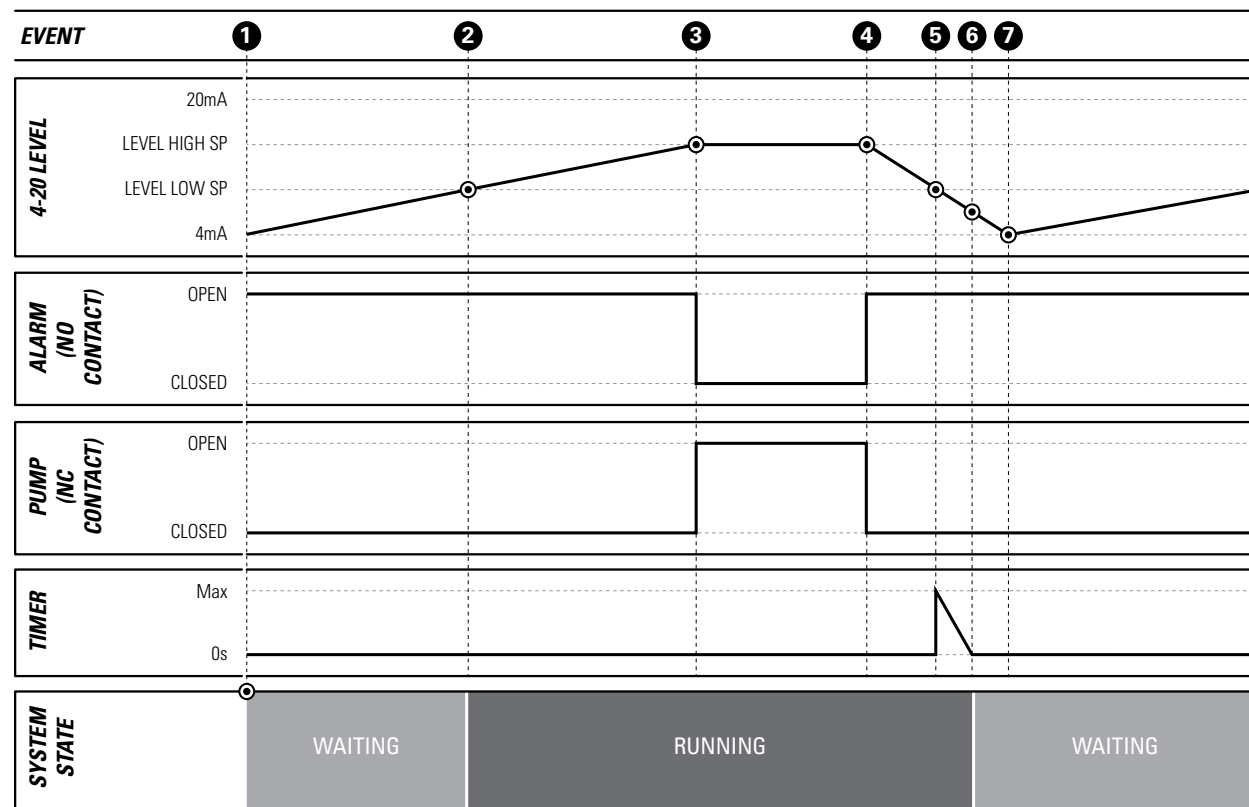

#	CHART 1 EVENTS
1	System started with tank empty. Pump starts filling tank. Burner is off and system is waiting on level input because 4-20mA level input is below the low setpoint.
2	Tank level rises above low setpoint. System begins running (heating tank).
3	Tank level rises above the high setpoint, the pump turns off and the remote alarm turns on to signal a truck to come and empty the tank.
4	An operator arrives on site and begins emptying the tank into a tanker truck. The pump turns back on and the alarm turns off.
5	The tank level drops below the low setpoint and the level delay timer begins counting down.
6	The level delay timer reaches zero after 2 or 20s (depending on the "Pressure/Level Delay" setting) and the system stops heating the tank and returns to the "Waiting on Level" state.
7	The tank is empty and the tanker truck leaves the site. The tank level begins rising again.

#### 4-20MA PRESSURE INPUT

The 4-20 Pressure Input is used to monitor fuel train pressure in the same way as the Pressure Contacts. The behavior and features are similar to those described in the previous [Low Pressure Contact](#) and [High Pressure Contact](#) sections. One difference is that a Pressure Transmitter is used instead of a pair of Pressure Switches and the setpoints are set via a menu instead of mechanically on the switches. When the 4-20 signal is below the low setpoint or above the high setpoint, the system will stop. When it is between the two setpoints, it will run. The system can be started when the input signal is above the

high pressure setpoint. This is to allow for easy recovery from the common issue of leaky regulators. If the regulator upstream from the high pressure switch is leaky, it can allow pressure to accumulate at the switch's position over time while the system is not running. Since there is no way to relieve this pressure other than to open a downstream valve, the system must be allowed to start running under this condition. The system will start, light the pilot, and open the main valve to allow the built-up pressure to be relieved. If the pressure does not drop below the high pressure setpoint within 2 seconds after the main valve has been opened, the system will shutdown. Otherwise it will continue running. This behavior is depicted in charts 2 and 3 below. The system can be setup to restart from a low pressure event but not from a high pressure event.

#### To use the 4-20 Pressure Input, it must be setup as follows:

1. Attach a properly calibrated Pressure Transmitter to the 4-20 Pressure Input
2. Enable the Pressure DIP Switch on the 4-20 Card
3. Enable the 4-20 Card in menu 6
4. Set the Pressure Low Setpoint, High Setpoint, Range, and Units in menu 6
5. Disable the Low Pressure and High Pressure Contacts by installing a jumper in each of them

Chart 1: Pressure Increases While Running

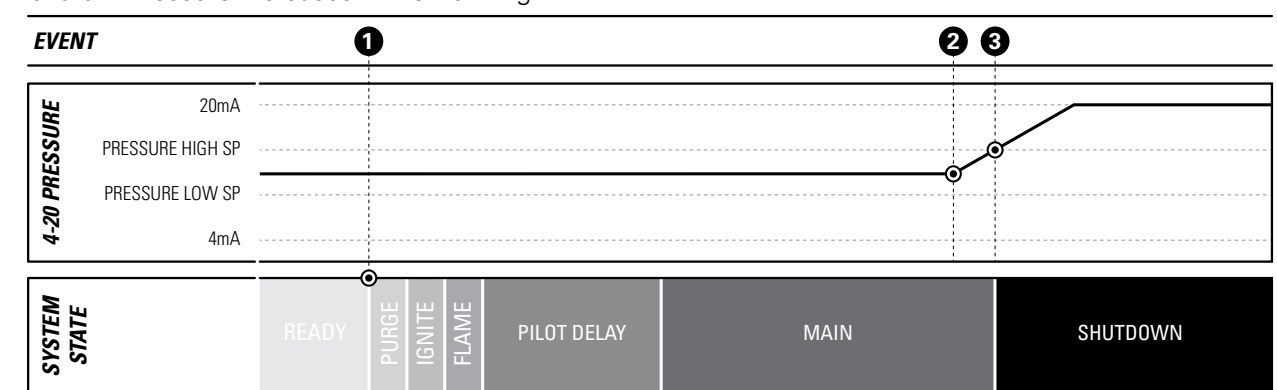

#	CHART 1 EVENTS
1	System started by user with pressure between low and high setpoints.
2	Pressure regulator fails while the mains are turned on. Pressure begins increasing.
3	Pressure exceeds High Setpoint. High pressure timer begins counting down.
4	Pressure continues to climb. After 2s, system shuts down.

Chart 2: Pressure High From Start

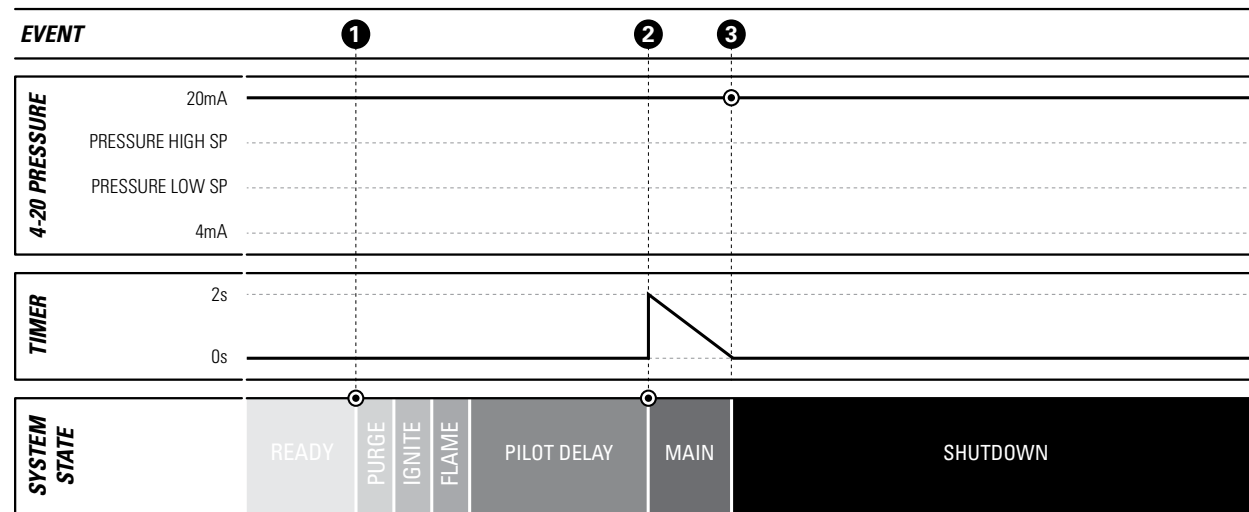

#	CHART 2 EVENTS
1	System started by user with pressure above high setpoint.
2	Main turns on and timer starts counting down 2s.
3	The timer expires and the pressure signal does not drop below the high setpoint. The system shuts down.

Chart 3: Pressure High On Start But Clears When Main Opens

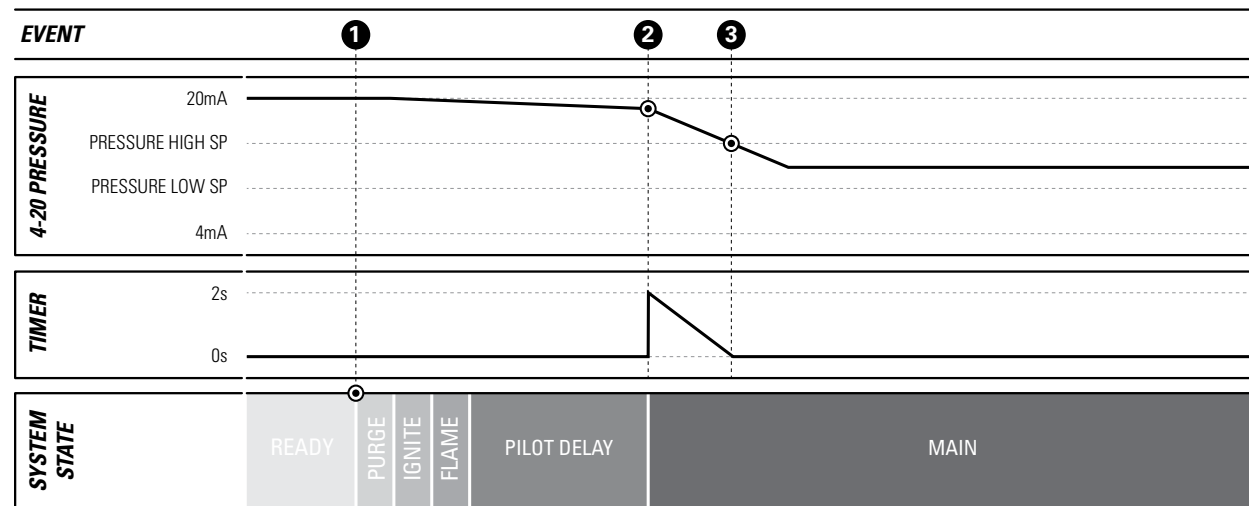

#	CHART 3 EVENTS
1	System started by user with pressure above high setpoint due to a slow leak in the regulator. Pressure begins to drop slowly through pilot valve.
2	Main valve opens and pressure begins to drop faster through main valves.
3	The pressure drops below the high setpoint within 2s of the main valves opening and the system continues running.

Chart 4: Auto Restart = Enabled

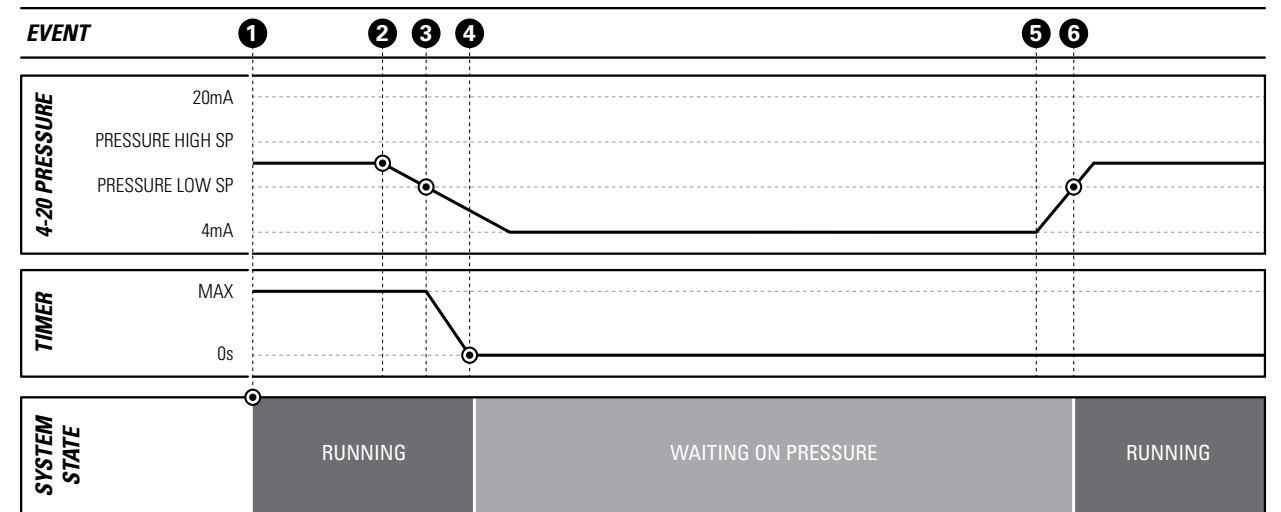

#	CHART 4 EVENTS
1	System already running with pressure between High and Low setpoints.
2	Hand valve on fuel train closed. Pressure begins to drop.
3	Pressure falls below the low set point. Delay timer starts counting down. (max valve depends on the Level/Pressure Delay setting)
4	Delay timer expires and burner turns off. System state is now "Waiting on Pressure."
5	Hand valve is opened and pressure increases quickly.
6	Pressure rises above low setpoint and system begins running again.

Chart 5: Level Event Restart = Disabled

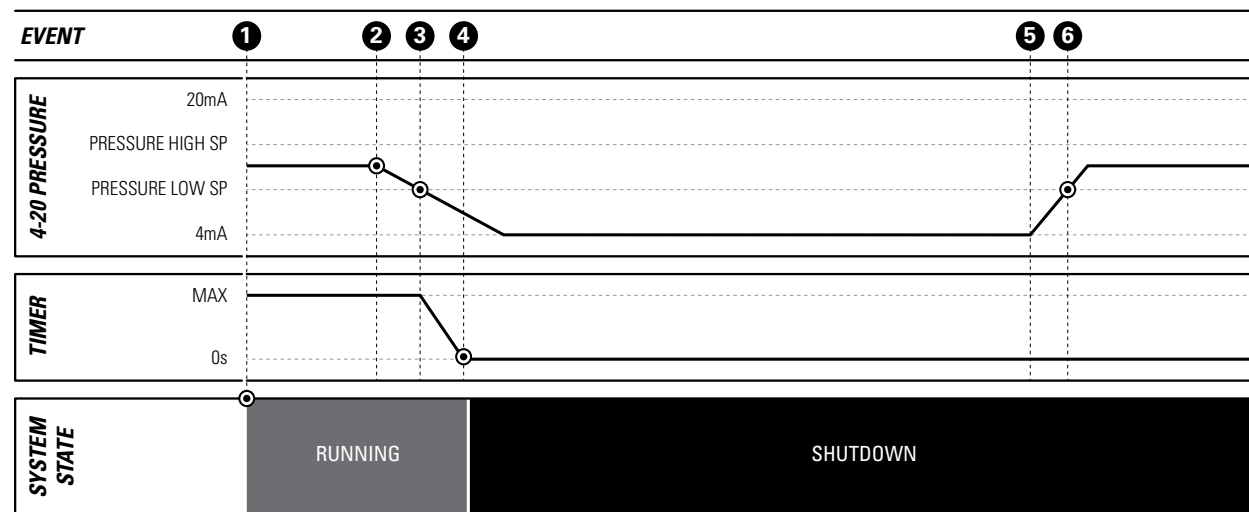

#	CHART 5 EVENTS
1	System already running with pressure between High and Low setpoints.
2	Hand valve on fuel train closed. Pressure begins to drop.
3	Pressure falls below the low set point. Delay timer starts counting down. (max valve depends on the Level/Pressure Delay setting)
4	Delay timer expires and system shuts down.
5	Hand valve is opened and pressure increases quickly.
6	Pressure rises above low setpoint but system does not restart and remains shut down.

#### 4-20MA TEMPERATURE OUTPUT

If the 4-20mA Output is not being used to control a proportional valve, it can be configured to output the process temperature encoded as a 4-20mA signal. This is useful if a PLC on site needs to know the process temperature. In this case, wire the PF2100's 4-20mA Output to a PLC's 4-20mA Input. Note that the PF2100 provides the loop power. The PLC resistance is expected to be in the range of 120 Ohms and 250 Ohms.

The 4-20mA output signal will be scaled such that 4mA represents OC and 20mA represents HT ESD Setpoint.

## 5.2 | Modbus Expansion Card

An optional Modbus Expansion Card can be installed in the PF2100 which provides the following additional features:

#### REMOTE MONITORING

This card allows for remote monitoring of the PF2100 status including process temperature, auxiliary temperature, and 4-20mA Input Card status (if installed).

#### REMOTE START / STOP

This card can also be used to remotely start and stop the system and to adjust some setpoint values.

#### REMOTE SETPOINT ADJUSTMENT

This card can be used to remotely adjust some setpoints such as High Fire, Low Fire, and Pilot Off setpoints. Note that these settings are not stored in memory. If the system is powered off and then on again, these settings will revert back to the last values entered directly using the keypad.

Refer to the "Modbus Expansion Card Manual" for further details on installation and operation of this card.

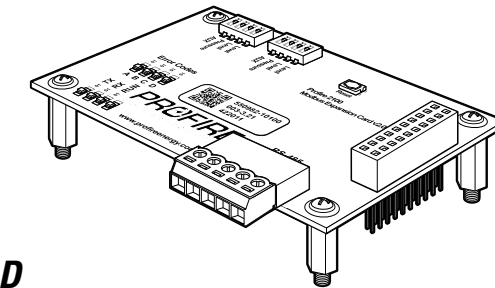

#### MODBUS EXPANSION CARD

Some PF2100 models come with this card pre-installed.

#### MODBUS EXPANSION CARD SETTINGS

This setting applies to the Modbus Expansion Card which must be installed in the PF2100's expansion slot.

##### Modbus Enable/Address (menu 6)

The Modbus Card is disabled by setting the address to zero and enabled by setting the address to any non-zero value. The address is shown on the display as a decimal number which can be set to any value in the range of 1 to 254. This corresponds to hexadecimal values 0x01 to 0xFE.

# 6 | TROUBLESHOOTING

This section is designed to help you troubleshoot the PF2100. A list of common issues and solutions, reference tables containing Shutdown Messages, Alarm Codes, and Warning Messages, and step-by-step guides for troubleshooting specific issues are included in this section.

If you are having trouble with your PF2100 System, please consult the following resources in this order:

1. Consult this section for solutions to see if one matches your needs.
2. Consult the support section of our website at [www.profireenergy.com](http://www.profireenergy.com).
3. Contact us on our support line at 1-855-PRO-FIRE (776-3473).

## 6.1 | Common Issues & Solutions

Under each issue is a list of possible solutions.

### EXPANSION CARDS

#### Cannot Write Setpoints via Modbus

1. Check that the system has the latest firmware. Firmware older than v1.8.005 did not support this feature.
2. Check that the Modbus Card has the latest firmware. Firmware older than v4.0 did not support this feature.

### FLAME DETECTION

#### System Has Visible Flame But Cannot Detect It

1. The flame rod, pilot assembly and the gap between them should be fully engulfed in flame. If not, adjust the rod positioning.
2. Check that the flame detection wiring does not exceed the recommended maximum length.
3. Check that the Ion+ wire is securely connected as per the appropriate wiring diagram.
4. Check that the ground connection between the PF2100 and the pilot assembly is secure.
5. Put the PF2100 into Manual Mode and use the Review Menu to check the flame quality level.
6. Consult the instructions in the Flame Detection Troubleshooting Guide for further details on Flame Detection.

### SHUTDOWN

#### System Shuts Down with a High/Low Voltage Message Shutdown

1. Make sure that the system voltage setting matches the power supply's nominal voltage.
2. Check that the system has the latest firmware. Firmware older than v1.8.005 was prone to shutdown on transient voltage spikes and dips.
3. Make sure that some other load is not causing the supply to drop periodically. Remove other devices from the supply or, monitor the supply voltage with a data logger.
4. Make sure the power supply is rated appropriately for the valves and other peripheral devices attached to the PF2100.

#### System Shuts Down On High Temperature ESD

1. Check that the HT ESD setpoint is not set too close to the operating temperature of the system. Measurement accuracy and process control overshoot can cause the system to shutdown if they are too close.

#### System Shuts Down On an Open TC Error

1. Check the thermocouple connections inside the PF2100. Note that both the Process and High Temp thermocouples are required.
2. Check for breaks in the thermocouple wiring.

#### System Shuts Down On TCS Not Being Equal

1. Press the Up and Down arrows together.
2. Press the Up arrow until you get to a screen with 4 temperature readings, DH, TH, TP and TA.
3. If the TH and TP readings are close but DH is different, follow these steps:
4. Go to the calibration menu.
5. Step through the menu to Cal High Temp = xxxC.
6. Press the Up arrow once.
7. Press OK.
8. Go back to the screen with the temperature readings and make sure the issue is corrected.

### SOLAR POWER

#### Solar Output Voltage is 12V when 24V is Expected

1. Check solar panel wiring. They should be wired in parallel rather than in series.

#### Expected Battery Life is Not Achieved

1. The PF2100 is not set up by default to use low power valves with a PWM setting of 20%.
2. The PF2100 is not set up to put the display to sleep when not in use.
3. The solar panel is undersized.
4. The solar panel is shaded or not located in full sun.

#### The Battery is Not Being Charged at All

1. Check the Solar Charger for damage or defective parts. Look

- for flashing error codes on the controller's LEDs.
- 2. The solar panel is undersized.
- 3. The solar panel is shaded or not located in full sun.
- 4. The battery is defective.

## SOLENOIDS

### Valves Are Not Opening

1. Check if the positive and negative wires are reversed.
2. Make sure that each valve has a separate negative return wire connected to the correct terminal. A common ground wire cannot be used and will not work.
3. Check if the proper PWM setting is used for each valve.
4. Check if the valve voltage ratings match the system voltage (12V or 24V).

### System Shuts Down With Terminal Card Command Refused, Master Power, Solenoid Feedback.

Check the solenoid wiring to make sure that no wires are crossed and that separate return wires are used for each valve.

## STATUS CONTACT

### Status Contact Opens but System Continues To Run

Check that the system has the latest firmware. Some firmware versions older than v1.8.005 had a bug that might lead to this under certain circumstances. If you can't update your firmware immediately, repositioning the flame rod so that it is more fully immersed in the flame can lessen the occurrence of this issue.

### Status Contact Remains Closed Even When The System is Stopped

The status contacts are polarity sensitive. Try reversing the Status+ and Status- wires.

### Status Contact Never Closes

The current or voltage ratings on the status contact may have been exceeded. Verify that you are not exceeding these ratings. If the ratings were exceeded, check the terminal Card HW version to determine the appropriate solution. (v1.6: Replace the Terminal Card.) (v1.7: Replace the Status Contact Fuse on the Terminal Card.)

## THERMOCOUPLES

### Thermocouple Readings are Bouncing

1. Verify that the Valve PWM Settings are correct for the valves being used. Using incorrect settings for a valve can result in more noise than necessary. The lowest noise will result when the PWM setting is set to 20% for low power valves and

100% for regular valves.

2. Verify that proper system grounding is in place. Especially check that all solenoids are connected to earth ground.

### Thermocouple Readings are Incorrect

1. Check if the thermocouple wiring polarity is reversed. Yellow should be connected to positive, and red to negative.
2. Check that no thermocouple pairs are crossed (ie, positive from one TC paired with negative from another TC).
3. Make sure that only Type-k thermocouple wire and connectors are used. Even small sections of other types of wire can significantly disrupt the measurement.
4. If a head connection is used, verify that none of the above wiring issues exist there either.
5. Check if the thermocouple is defective by trying a different thermocouple that is known to be good or by connecting the suspect thermocouple to a process calibrator.
6. Check that the PF2100 is in proper calibration using a process calibrator. If not, recalibrate the system.

## 6.2 | Shutdown Messages

The following is a list of messages that may flash on the PF2100 display after the system has shutdown. Typically, the word "SHUTDOWN" in large text will flash alternately with one of the messages below. These messages indicate the reason that the system last shutdown and can be cleared by pressing the OK key (except where noted). Use the table below to determine the meaning of these messages. This table is organized alphabetically.

ON SCREEN	DESCRIPTION	POSSIBLE SOLUTIONS
Ambient Temps Not Equal	The Ambient Temperature read by the Door Card does not match the one reported by the Terminal Card.	The door card and terminal card are different temperatures. Check to see if one board is being heated by an external source such as direct sun on the door or being mounted on a hot tank.
Aux High Temp	Aux Temp Mode is set to "Temp ESD" and the Auxiliary Temperature exceeded the High Temp ESD Setpoint.	Verify proper settings and check for issues outside the system.
Aux Thermocouple Error	The Auxiliary Thermocouple is open.	Check wiring.
Comparison Setpoints	One of the Setpoints in the Door Card does not match the corresponding value in the Terminal Card.	Reset system to factory defaults.
Comparison: C_byte x y	The Door Card's internal control byte (x) did not match the Terminal Card's internal status byte (y).	Remove solenoid wires; if the problem is resolved check the solenoid wiring. If the problem remains the same, the boards or ribbon cable may need to be replaced.
Comparison: ESD DC:xxx TC:xxx	The Door Card and Terminal Card do not agree on the state of the ESD Contact." xxx" will be either "ON" or "OFF"	Remove ESD wires and jumper the terminals, if the problem is resolved check the wiring. If the problem remains the boards or ribbon cable may need to be replaced.



ON SCREEN	DESCRIPTION	POSSIBLE SOLUTIONS
Comparison: LVL DC:xxx TC:xxx	The Door Card and Terminal Card do not agree on the state of the Level Contact. "xxx" will be either "ON" or "OFF".	Remove level contact wiring and jumper the terminals, if the problem is resolved check the wiring. If the problem remains the boards or ribbon cable may need to be replaced.
Comparison: MAN DC:xxx TC:xxx	The Door Card and Terminal Card do not agree on the state of the Main Valve Output. "xxx" will be either "ON" or "OFF".	Remove solenoid wires; if the problem is resolved check the solenoid wiring. If the problem remains the same, the boards or ribbon cable may need to be replaced.
Comparison: PLT DC:xxx TC:xxx	The Door Card and Terminal Card do not agree on the state of the Pilot Valve Output. "xxx" will be either "ON" or "OFF".	Remove solenoid wires; if the problem is resolved check the solenoid wiring. If the problem remains the same, the boards or ribbon cable may need to be replaced.
Comparison: PoC DC:xxx TC:xxx	The Door Card and Terminal Card do not agree on the state of the Proof of Closure Contact. "xxx" will be either "ON" or "OFF".	Remove Proof of Closure contact wiring wires and jumper the terminals, if the problem is resolved check the wiring. If the problem remains the boards or ribbon cable may need to be replaced.
Comparison: PRH DC:xxx TC:xxx	The Door Card and Terminal Card do not agree on the state of the High Pressure Contact. "xxx" will be either "ON" or "OFF".	Remove high pressure contact wiring and jumper the terminals, if the problem is resolved check the wiring. If the problem remains the boards or ribbon cable may need to be replaced.
Comparison: PRL DC:xxx TC:xxx	The Door Card and Terminal Card do not agree on the state of the Low Pressure Contact. "xxx" will be either "ON" or "OFF".	Remove low pressure contact wiring and jumper the terminals, if the problem is resolved check the wiring. If the problem remains the boards or ribbon cable may need to be replaced.
Comparison: STRT DC:xxx TC:xxx	The Door Card and Terminal Card do not agree on the state of the Start Contact. "xxx" will be either "ON" or "OFF".	Remove start contact wiring and jumper the terminals, if the problem is resolved check the wiring. If the problem remains the boards or ribbon cable may need to be replaced.
Control Error	The Internal Control State is not valid.	One of the boards will likely need to be replaced.
DC MSP430 No Communications	The TC430 Temperature chip on the Door Card is not responding.	Faulty Door Card
EEPROM Error	The EEPROM settings are corrupted.	Faulty Door Card
ESD Input	The ESD Input was open while the system was running or attempting to start.	Check wiring.
Expansion Card Error / 4-20 Exp Card: 4-20 Level Low	The 4-20mA Level Input was below the Level Low Setpoint while the system was running with the Level Event Restart feature disabled.	Verify proper settings and check for issues outside the system.
Expansion Card Error / 4-20 Exp Card: 4-20 Level Open	The 4-20mA Level Input is open (reading below ~ 3.75mA)	Check wiring.
Expansion Card Error / 4-20 Exp Card: 4-20 PRS High	The 4-20mA Pressure Input was above the Pressure High Setpoint while the system was running with the Main Valve open.	Verify proper settings and check for issues outside the system.
Expansion Card Error / 4-20 Exp Card: 4-20 PRS Low	The 4-20mA Pressure Input was below the Pressure Low Setpoint while the system was running with the Auto Restart feature disabled.	Verify proper settings and check for issues outside the system.
Expansion Card Error / 4-20 Exp Card: 4-20 PRS Open	The 4-20mA Pressure Input is open (reading below ~ 3.75mA)	Check wiring.
Expansion Card Error / 4-20 Exp Card: Card Fail	The 4-20mA Expansion Card is not responding.	This may indicate that the card is not installed correctly or that the feature is enabled when the card is not present.
Expansion Card Error / Modbus Card: Card Fail	The Modbus Expansion Card is not responding.	This may indicate that the card is not installed correctly or that the feature is enabled when the card is not present.

ON SCREEN	DESCRIPTION	POSSIBLE SOLUTIONS
Flame detected before start	Flame was detected prior to the system igniting the pilot.	This may indicate a leaky valve, inadequate purge time, or a faulty Terminal Card.
Flame Fail	The system failed to ignite the pilot within the allocated number of retry attempts.	See the Flame Detection Troubleshooting section.
Flame Rod Test Error / Adjust Flame Rod Position	The Flame Rod or associated wiring may be shorted to ground thus preventing it from properly detecting flame.	If the error shows up immediately and does not allow you to start the system, remove the 4 pin terminal block to the ignition coil and try starting again. If you can start the system, there is a wiring problem. If you cannot start the system, one of the boards or the ribbon cable may be faulty.  If the system runs for a while and then shuts down with this error after a random amount of time, the problem is that the flickering of the flame is lining up with the internal self test. Usually moving the rod more into the flame will resolve this issue.
High Pressure	The High Pressure Contact is open or the 4-20mA pressure reading remained above the 4-20mA Pressure High Setpoint for 2s after the main valve opened.	Verify proper settings and check for issues outside the system.
High Temp	The Process Temperature rose above the High Temp ESD Setpoint.	Verify proper settings and check for issues outside the system.
High Temp Setpoint Mismatch	The Door Card and Terminal Card do not agree on the value of the High Temp ESD Setpoint.	Reset to factory defaults.
High Voltage xx.x Volts	The system voltage remained above the High Voltage Alarm point for 20s or more and Auto Restart is disabled. "xx.x" is the voltage reading at the point in time when the shutdown occurred.	Verify proper settings and check for issues outside the system.
HT Thermocouple Error	The High Temp Thermocouple is open.	Check wiring.
Ignite Key Stuck	The Ignite Key was held for more than 30s while in manual mode.	Check for mechanical failure of the key.
Key Stuck Error / xxxx	One of the keypad keys was stuck at System Startup. The particular key stuck will be displayed in place of xxxx and will be one of the following:  DOWN, IGN, MAIN, MODE, OK, PLT, MENU, STOP, UP	This may indicate a defective keypad. This error must be resolved in order to continue using the system.
Level Input	The Level Contact is open and "Level Event Restart" is set to "Off". This error can also be triggered by the 4-20 Input Card if the Level reading is below the 4-20 Level Low Setpoint and "Level Event Restart" is set to "Off"	Verify proper settings and check for issues outside the system.
Low Pressure	The Low Pressure Contact is open and "Auto Restart" is set to "Off". This error can also be triggered by the 4-20 Input Card if the Pressure reading is below the 4-20 Pressure Low Setpoint and "Auto Restart" is set to "Off".	Verify proper settings and check for issues outside the system.
Low Voltage xx.x Volts	The system voltage remained below the Low Voltage Alarm point for 20s or more and "Auto Restart" is set to "Off" "xx.x" is the voltage reading at the point in time when the shutdown occurred.	Verify proper settings and check for issues outside the system.



ON SCREEN	DESCRIPTION	POSSIBLE SOLUTIONS
Master Power Error	The Master Power switch to the powered valve outputs was in the wrong state.	Remove all valve wires and run the system. If the problem resolves, there is a wiring issue with the solenoids. If the problem remains, the Terminal Card is likely damaged. Check the solenoid connections for shorts to ground or across the terminals before installing a new board.
Modbus Card: Shutdown	The system shut down because a remote shutdown command was received via Modbus.	Check the data being sent through the Modbus connection.
Modbus Card: Shutdown / Remote Cmd Error	The system received an undefined command from the Modbus Expansion Card.	Check the data being sent through the Modbus connection.
Pilot Key Stuck	The Pilot Key was held for more than 30s while in manual mode.	Check for mechanical failure of the key.
Pro Thermocouple Error	The Process Thermocouple is open or shorted.	Check wiring.
Proof of Closure / Should be Closed	The Proof of Closure Contact was detected to be Open when it was not expected to be.	This may indicate a faulty valve or wiring.
Purge Values Mismatch	The Door Card and Terminal Card do not agree on the value of the Purge Time Setting.	Reset to factory defaults.
Run CRC Error	Main Program Memory CRC Error	Reset to factory defaults.
Solenoid Feedback Error / Check Solenoid Wiring	The solenoids were observed to have a state opposite to the one being driven by the PF2100.	Remove all valve wires and run the system. If the problem resolves, there is a wiring issue with the solenoids. If the problem remains, the Terminal Card is likely damaged. Check the solenoid connections for shorts to ground or across the terminals before installing a new board.
System Error	Illegal Process Control or Display State	Reset to factory defaults.
Terminal Card Ambient Fail	The Terminal Card could not measure the ambient temperature. The Door Card failed to detect this.	Reset to factory defaults. Likely a faulty terminal card.
Terminal Card Command Refused	The Terminal Card received a valid command from the Door Card but the command was refused because it would result in an invalid or unsafe state. The Door Card failed to detect this.	Remove all valve wires and run the system. If the problem resolves, there is a wiring issue with the solenoids. If the problem remains, the Terminal Card is likely damaged.
Terminal Card Communication	The Terminal Card is not communicating with the Door Card. This may indicate a faulty ribbon cable or incompatible firmware. The Door Card failed to detect this.	Make sure the ribbon cable is properly installed. Likely a fault with door, ribbon or terminal.
Terminal Card High TC Grounded	The Terminal Card detected that the High Temp Thermocouple was shorted to ground. The Door Card failed to detect this.	Check for continuity from the high temp TC to ground. If there is no connection remove the thermocouple and replace it with a jumper. If the problem persists it is likely a door or terminal card fault.
Terminal Card High Temp Alarm	The Terminal Card detected that the High Temp Thermocouple exceeded the High Temp ESD Setpoint. The Door Card failed to detect this.	Check for continuity from the high temp TC to ground. If there is no connection remove the thermocouple and replace it with a jumper. If the problem persists it is likely a door or terminal card fault.
Terminal Card Reciprocal Comp	The Terminal Card detected that the Door Card status or High Temp ESD Setpoint did not match. The Door Card failed to detect this.	Reset to factory defaults. Remove all wires but power, install default jumpers. If the problem persists there is likely a problem with the one of the boards.
Terminal Card Shutdown Detect	The Terminal Card detected an alarm condition. The Door Card failed to detect this.	Reset to factory defaults. Remove all wires except power; install default jumpers. If the problem persists there is likely a problem with the one of the boards.

ON SCREEN	DESCRIPTION	POSSIBLE SOLUTIONS
Terminal Card Voltage Sense	The Terminal Card detected that the system voltage was outside of allowable limits. The Door Card failed to detect this.	Reset to factory defaults. Remove all wires except power; install default jumpers. If the problem persists there is likely a problem with the one of the boards.
Thermocouples Not Equal / Check Wiring	The High Temp and Process Thermocouples are reading temperatures that are too far apart.  This may indicate a failed thermocouple or improper wiring.	Check thermocouple readings with dry block or process calibrator.
User Stop	The user pressed the Stop key on the keypad.	

## 6.3 | Alarm Codes

The following is a list of alarm codes that may show on the Alarm screen of the PF2100 display. These codes indicate a persistent problem that must be cleared before the system can be restarted. Use the table below to determine the meaning of these codes.

ON SCREEN	DESCRIPTION	POSSIBLE SOLUTIONS
4-20Lvl	The 4-20 Input Card's Level Input is reading a value below the 4-20 Level Low Setpoint and "Level Event Restart" is set to "Off"	Verify proper settings and check for issues outside the system.
4-20Prs	The 4-20 Input Card's Pressure Input is reading a value below the 4-20 Pressure Low Setpoint and "Auto Restart" is set to "Off"	Verify proper settings and check for issues outside the system.
AuxTC	The system is in a mode that requires the Aux Thermocouple and the Aux Thermocouple is open or otherwise wired incorrectly.	Check wiring.
DC_TC	The TC430 temperature sensor on the Door Card is not responding.	
ESD_Inp	The ESD Contact is Open.	Check wiring.
FlmTest	There is a problem with the Flame Detection wiring or circuitry.	Check wiring.
PoC_Inp	The Proof of Closure contact is open.	Check wiring.
HiVolt	The system voltage is above the High Voltage Alarm point.	Verify proper settings and check for issues outside the system.
HT_ESD	The Process Temperature is above the High Temp ESD Setpoint.	Verify proper settings and check for issues outside the system.
HT_TC	The High Temp Thermocouple is open or otherwise wired incorrectly.	Check wiring.
LoVolt	The system voltage is below the Low Voltage Alarm point.	Verify proper settings and check for issues outside the system.
LowPrs	The Low Pressure Contact is Open or the 4-20mA Expansion Card's Pressure Input is reading a value below the 4-20 Pressure Low Setpoint. In either case, "Auto Restart" is set to "Off"	Verify proper settings and check wiring.





ON SCREEN	DESCRIPTION	POSSIBLE SOLUTIONS
Lvl_Inp	The Low Level Contact is Open or the 4-20mA Expansion Card's Level Input is reading a value below the 4-20 Level Low Setpoint. In either case, "Level Event Restart" is set to "Off".	Verify proper settings and check wiring.
MbusErr	The Modbus Card is not responding.	This may indicate that it is not installed correctly or that it is enabled when not present at all.
ProcTC	The Process Thermocouple is open or otherwise wired incorrectly.	Check wiring.
RemShut	Modbus Shutdown Command Received	Check the data being sent through the Modbus connection.
Sys_Err	System Error – The Terminal Card is not communicating with the Door Card.	This may indicate a faulty ribbon cable or incompatible firmware.
TC_MM	The High Temp and Process Thermocouples are reading temperatures that are too far apart.  This may indicate a failed thermocouple, improper wiring, or a damaged Door or Terminal Card.	Check thermocouple readings with dry block or process calibrator.
Va_MM	The Door and Terminal Card's setpoints do not match.	Reset to factory defaults.

## 6.4 | Warning Messages

The following is a list of warning messages that may flash periodically on the PF2100 display. These messages indicate a problem that may be developing or a condition from which the system may automatically restart once cleared. Use the table below to determine the meaning of these messages.

ON SCREEN	DESCRIPTION
Check all settings / Other settings have changed	A major process control setting was changed and the process control setpoints were reset to factory defaults. This includes the High Temp ESD Setpoint, the Pilot Off Setpoint, the Low Fire Setpoint, the Process Setpoint, the Low Temp Alarm Setpoint, the Deadband setting, and the Aux Setpoint.
HI Volt Warning	The system voltage is getting close to the High Voltage Alarm threshold and may stop or shutdown soon.
High Prs Warning	The High Pressure Contact is open or the 4-20 Pressure Input is above the 4-20 Pressure High Setpoint. The contact must be closed for the system to run and the 4-20 Pressure input must be below the setpoint within 2 seconds after the main valve opens to avoid shutdown.
LO Volt Warning	The system voltage is getting close to the Low Voltage Alarm threshold and may stop or shutdown soon.
Low Temp Alarm	The process temperature is below the Low Temp Alarm Setpoint and the Status Contact is Open.
Unit restarted from LVL event	The system has recently restarted from a Level event. Press OK to clear this message.
Unit restarted from PRS event	The system has recently restarted from a Low Pressure event. Press OK to clear this message.
Unit restarted from VLT event	The system has recently restarted from a Low or High Voltage event. Press OK to clear this message.
Waiting: 420 LVL	The system will automatically restart once the 4-20 Input Card's Level Input rises above the Low Setpoint.
Waiting: 420 PRS	The system will automatically restart once the 4-20 Input Card's Pressure Input drops below the High Setpoint.
Waiting: HiVolt	The system will automatically restart once the system voltage falls below the High Voltage Alarm Threshold.
Waiting: LoVolt	The system will automatically restart once the system voltage rises above the Low Voltage Alarm Threshold.
Waiting: Low PRS	The system will automatically restart once the Low Pressure Contact is closed.
Waiting: LVL	The system will automatically restart once the Level Contact is closed.
Waiting:STRT Inp	The system will automatically restart once the Start Contact is closed.



## 6.5 | Flame Detection Troubleshooting Guide

### SYSTEM IS NOT DETECTING FLAME.

The flame quality drops from 100% (pilot) when the main comes on.

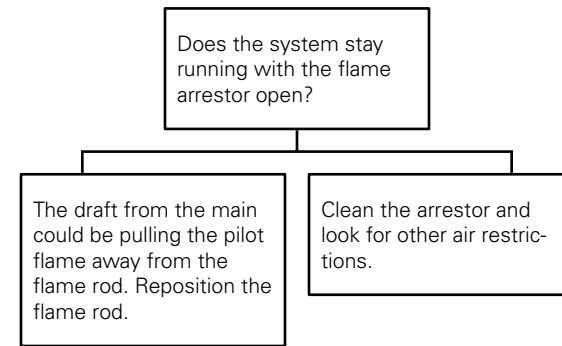

Flame quality remains 100% (pilot) when the main comes on.

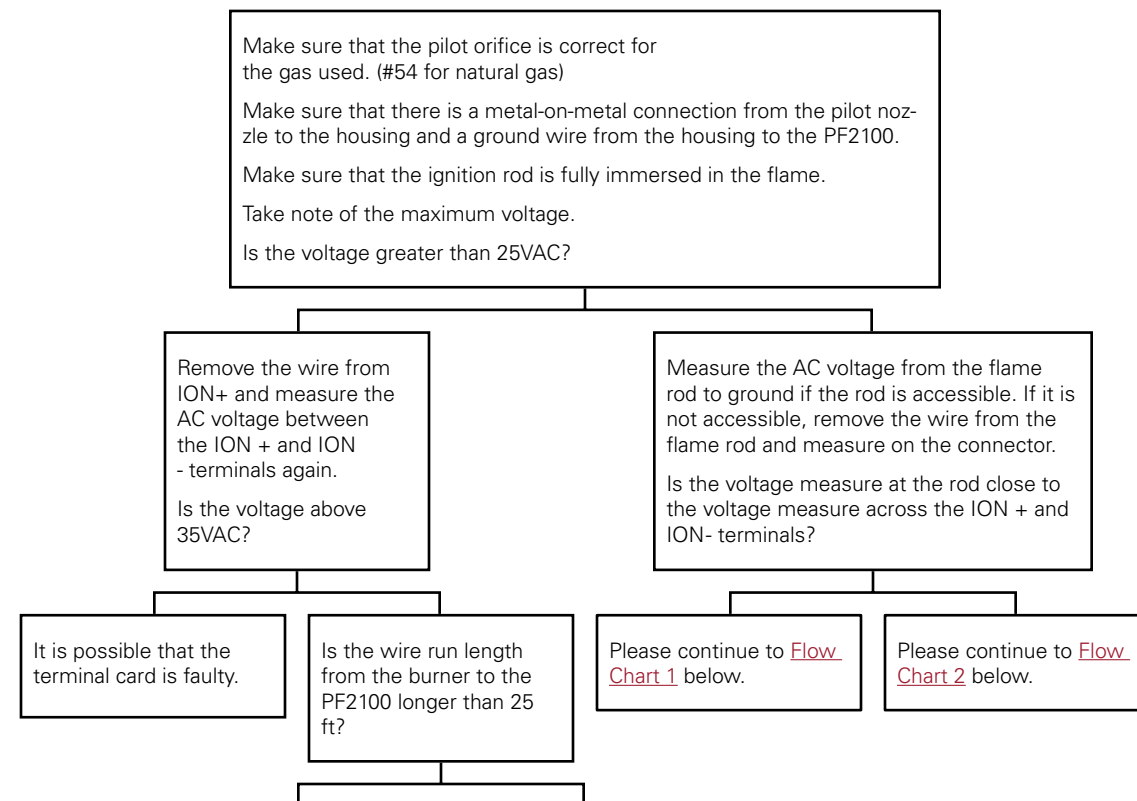

Something is loading the signal. Make sure that the wire type is not shielded. Look for partial ground shorts or nicked wires.

The length loading on the wire is too high. Using ignition wire for ION + will allow the signal to be run up to 50 ft. Using separate rods for flame detection and ignition can also reduce the ION + load by bypassing the coil.

### Flow Chart 1

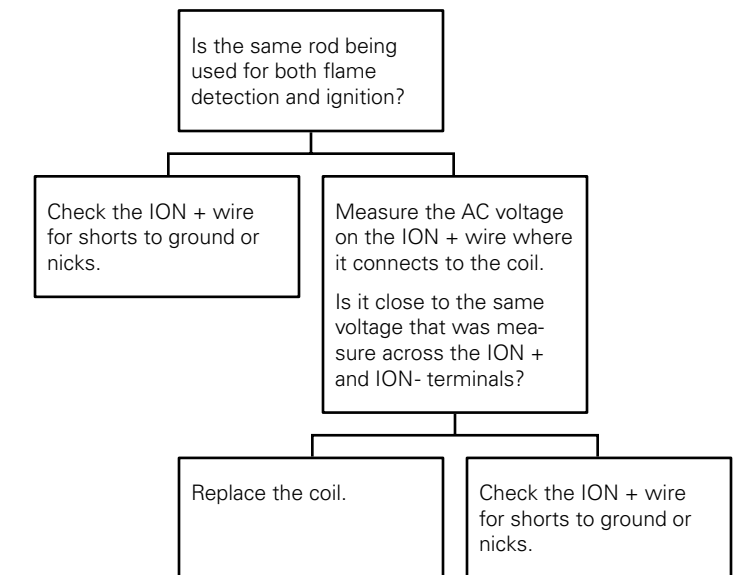

Flow Chart 2

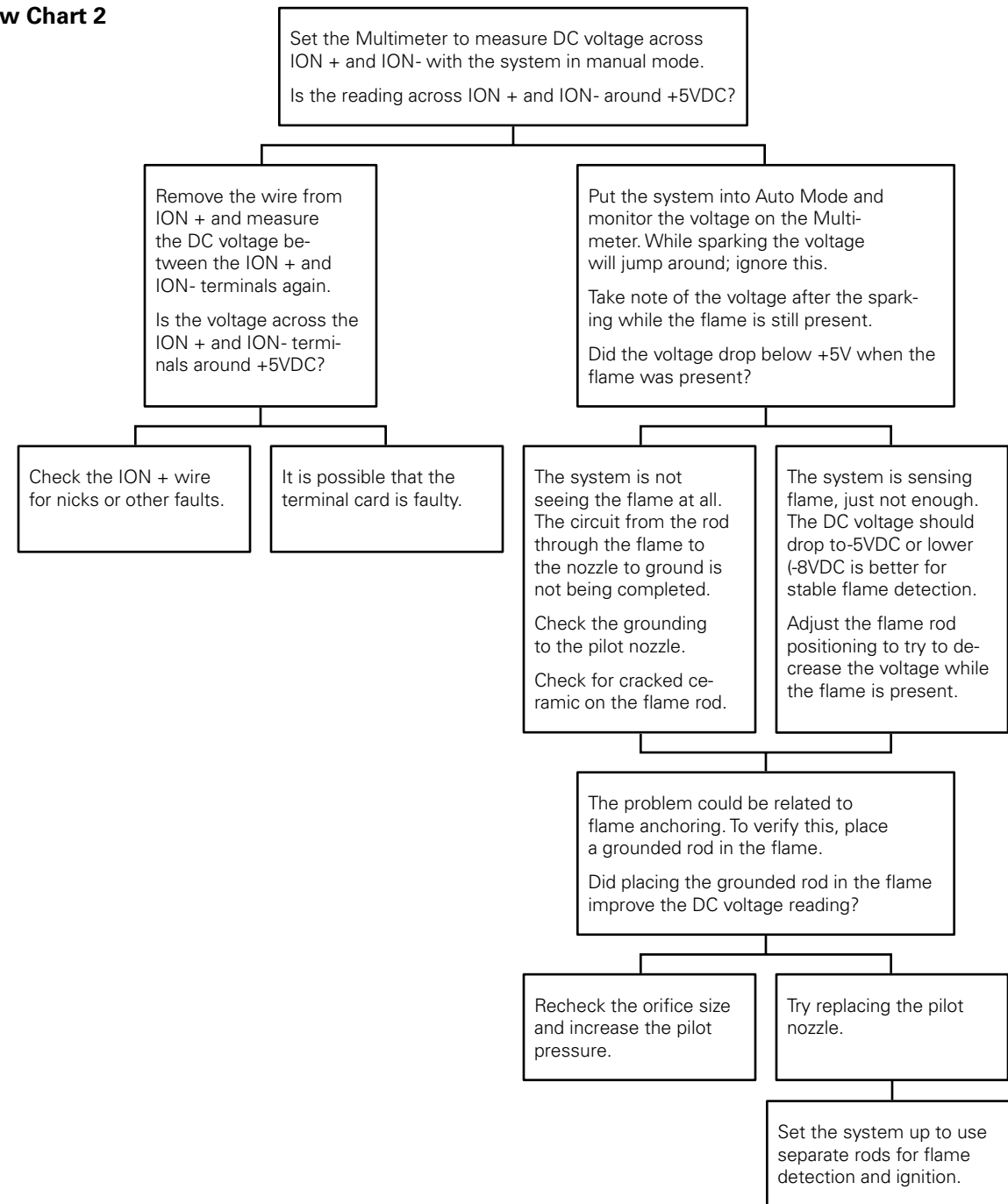

## 6.6 | Thermocouple Troubleshooting Guide

Problem with Thermocouples.

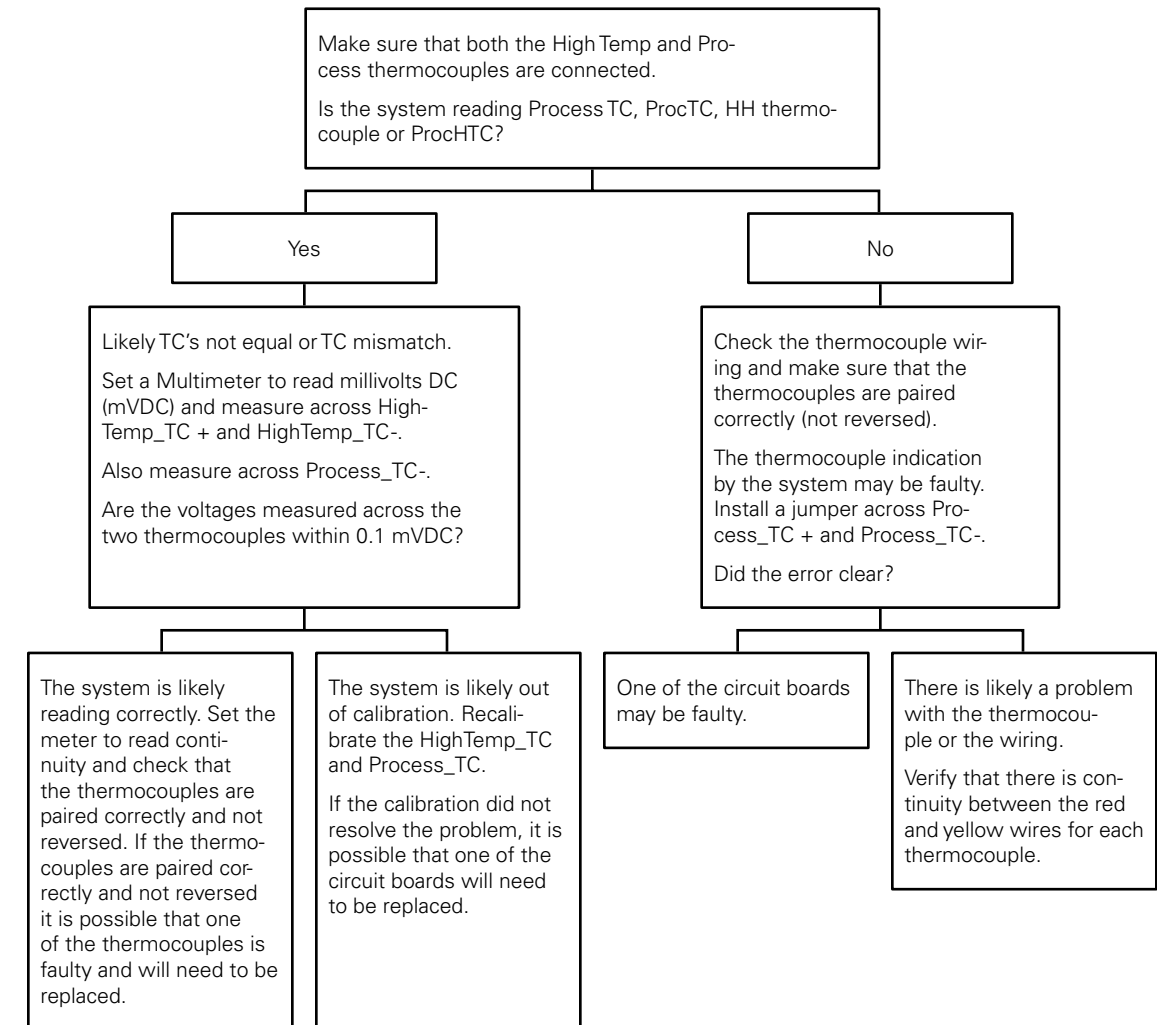

# APPENDICES

## A | PID Tuning Procedure

The PF2100's default PID settings should result in good temperature control in most common heater applications. If the temperature control is unstable or if faster control response is needed, the following procedure can be followed to adjust the PID settings. This procedure is not a comprehensive method for adjusting PID Controllers but provides some general guidelines. This procedure is iterative and therefore may require a significant amount of time to follow.

### TUNE THE PROPORTIONAL BAND SETTING

1. Start with the Proportional Band Setting set to a large value such as 500% and with the Integral and Derivative settings set to their default values (4.0min/rst and 0.0min respectively).
2. Make a small step change (such as 5%) to the Process Setpoint and monitor the resulting temperature change.
3. Repeat decreasing the Proportional Band Setting in 50% steps until a Process Setpoint change results in overshoot of the Process Setpoint or until oscillation results.
4. Increase the Proportional Band Setting until overshoot and oscillation no longer occur.

### TUNE THE INTEGRAL SETTING

1. Set the Integral setting to 10min/rst.
2. Make a small change to the Process Setpoint and monitor the temperature change.
3. Repeat decreasing the Integral in ½ minute steps until a Process Setpoint change results in overshoot of the Process Setpoint or until oscillation results
4. Increase the Integral Setting until stable.

### TUNE THE DERIVATIVE SETTING

If there is noise on the thermocouple inputs, using the Derivative Setting can dampen the effects of the Proportional and Integral Settings. For this reason, the Derivative Setting can usually be left set at zero unless a very fast response is needed. If it is required, follow this tuning procedure:

1. Set the Derivative Setting to 10 minutes.
2. Decrease the Derivative Setting until a small Process Setpoint change results in a fast response with some oscillation
3. Increase the Derivative Setting until the oscillation in response to a Process Setpoint change is dampened

## B | Field Calibration

It is possible to field calibrate the thermocouples, the 4-20mA Output, and the two 4-20mA Inputs on the 4-20mA Expansion Card. In general, it should not be necessary to do this in the field because the system has already been calibrated at the factory. However, there are circumstances where this may be necessary such as if the door or terminal card was replaced in the field or if the system is very old and has drifted out of calibration. Before recalibrating the system, it is strongly recommended that you explore all other possible solutions first. Be sure to verify that system settings are correct and that the devices attached to the system are calibrated correctly. If it is deemed necessary to proceed with recalibrating the PF2100, follow the procedures below carefully. Failure to perform the calibration correctly may result in worse performance than if the system had been left alone.

The PF2100 uses a two-point calibration system to provide readings with greater accuracy than a single-point offset calibration. The first point compensates for any fixed offset in the system and the second point defines the slope. If the calibration fails for any reason, there is an option in the calibration menu to clear all calibration data.

### CALIBRATING THE THERMOCOUPLES

For thermocouples, the first calibration point is zero volts which corresponds to the ambient temperature of the terminal block where the thermocouple plugs into the Terminal Card. The second calibration point is referenced to a known temperature that is well above the ambient temperature. This temperature is typically the hottest temperature at which the system will operate but should not be higher than 750°C above ambient and should not be lower than ambient + 20°C.

1. Make sure that the system is stopped.
2. Remove the 3 pairs of thermocouple wires (High Temp, Process, and Aux) from the P8 Pluggable Header on the Terminal Card.
3. Press the UP and Down Keys simultaneously to unlock the Calibration Menu (menu 7) and to show the temperature debug screen in the ready menu, which are normally hidden.
4. Short each pair of thermocouple inputs individually using a jumper or short piece of copper wire (ie, short HT+ to HT-, short Proc+ to Proc-, and short Aux+ to Aux-) and make note of the TH, TP, and TA temperature values show on the debug screen (press down or up on the ready screen until all temperatures are shown at once).
5. Reconnect the 3 pairs of thermocouple wires (High Temp, Process, and Aux) using the full length of wire used at the installation to the P8 Pluggable Header on the Terminal Card.
6. Set the High Temp, Process, and Aux thermocouples to a calibrated reference temperature equal to the temperature values read in step 4 using a dry block or other calibrated reference.
7. Press the Menu Key repeatedly until menu 7 is shown.
8. Press OK. If prompted, enter the L2 Password: ▲▼▲▲▼▲■
9. "Cal Proc TC Zero" will show on the display.
10. Press OK and the message "Calibrating Wait..." will appear on the display for about 5 seconds. Afterwards, the message "Parameter Saved" will show on the display briefly.
11. Press the Menu Key to go to the next item.
12. Repeat steps 10 and 11 for the "Cal HiTemp TC Zero" and "Cal



Aux TC Zero” menu items.

13. Set the High Temp, Process, and Aux thermocouples to a known reference temperature using a dry block or other calibrated reference. The reference temperature should be at least 20C above the ambient temperature and preferably close to the maximum planned operating temperature.
14. “Cal Proc TC Span” will show on the display.
15. Use the Up and Down Keys to adjust the temperature displayed on the PF2100 to match the temperature being applied to the thermocouple. Note that multiple key presses may be required before the temperature value on the display changes. This is because each key press is adjusting a fractional multiplication factor internal to the system.
16. Press OK and the message “Parameter Saved” will show on the display briefly.
17. Press the Menu Key to go to the next item.
18. Repeat steps 15-17 for the “Cal HiTemp TC Span” and “Cal Aux TC Span” menu items.
19. Press and hold the OK key for 3 seconds until the message “Password Logout” is displayed on the screen. The Calibration Menu is now hidden again.

NOTE: If using a dry block for calibration, make sure that the thermocouple is removed from the bath and inserted into the dry block long enough for the temperature reading to settle before executing the calibration. If a process calibrator is used, ensure that the thermocouple wire is inserted directly into the process calibrator to avoid extra sources of error and be aware that the length of wire within the thermocouple will not be accounted for, resulting in a less accurate calibration result.

#### CALIBRATING THE 4-20mA OUTPUT

For the 4-20mA Output, the first calibration point is 4mA and the second calibration point is 20mA. You will need a current meter capable of measuring current to 0.1mA accuracy.

1. Make sure that the system is stopped.
2. Connect a current meter in series with the 4-20mA Output.
3. Set the current meter to a range setting that covers both 4mA and 20mA.
4. Press the UP and Down Keys simultaneously to unlock the Calibration Menu (Menu 7) which is normally hidden.
5. Press the Menu Key repeatedly until Menu 7 is shown.
6. Press OK. If prompted, enter the L2 Password: ▲▼▲▲▼▲■
7. Press the Menu Key repeatedly until “Cal 4-20 Out Zero” is shown on the display.
8. Use the Up and Down Keys to adjust the output current until the current meter reads 4.0mA.
9. Press OK and the message “Parameter Saved” will show on the display briefly.
10. Press the Menu Key repeatedly until “Cal 4-20 Out Span” is shown on the display.
11. Use the Up and Down Keys to adjust the output current until the current meter reads 20.0mA.
12. Press OK and the message “Parameter Saved” will show on

the display briefly.

13. Press and hold the OK key for 3 seconds until the message “Password Logout” is displayed on the screen. The Calibration Menu is now hidden again.

#### CALIBRATING THE 4-20mA INPUTS

For the 4-20mA Output, the first calibration point is 4mA and the second calibration point is 20mA. You will need a handheld process calibrator such as the Fluke 725.

1. Make sure that the system is stopped.
2. Make sure that the card is installed and enabled in menu 6. The LVL and PRS DIP switches must also be enabled on the 4-20 mA card.
3. Press the UP and DOWN Keys.
4. Press the Menu Key repeatedly until menu 7 is shown.
5. Press OK. If prompted, enter the L2 Password: ▲▼▲▲▼▲■
6. Connect the process calibrator’s negative lead to the ground pin on the 4-20mA Input Card.

##### Calibrate the Level Zero

1. Press the Menu Key repeatedly until “4-20 Level Zero Calibration = No” is shown on the display.
2. Use the Up or Down key to select “Yes” and begin the calibration process. The display will now read “Apply 4mA then press OK”.
3. Disconnect any wiring that is connected to the Level input and instead attach the process calibrator’s positive lead in its place.
4. Turn on the process calibrator and set it to source a current of 4mA (0%).
5. Press the OK key and the message “Calibrating Wait...” will appear for several seconds followed by the message “Parameter Set” after the calibration has successfully completed.

##### Calibrate the Level Input’s Span point:

1. Press the Menu Key repeatedly until “Calibrate 4-20 LVL Span?” is shown on the display.
2. Use the Up or Down key to select “Yes” and begin the calibration process. The display will now read “Apply 20mA then press OK”.
3. Set the process calibrator to source a current of 20mA (100%).
4. Press the OK key and the message “Calibrating Wait...” will appear for several seconds followed by the message “Parameter Set” after the calibration has successfully completed.
5. Disconnect the process calibrator from the Level input and reconnect any wiring that was removed from it previously.

##### Calibrate the Pressure Input’s Zero point:

1. Press the Menu Key repeatedly until “Calibrate 4-20 PRS Zero?” is shown on the display.



2. Use the Up or Down key to select "Yes" and begin the calibration process. The display will now read "Apply 4mA then press OK".
3. Disconnect any wiring that is connected to the Pressure input and instead attach the process calibrator's positive lead in its place.
4. Turn on the process calibrator and set it to source a current of 4mA (0%).
5. Press the OK key and the message "Calibrating Wait..." will appear for several seconds followed by the message "Parameter Set" after the calibration has successfully completed.

**Calibrate the Pressure Input's Span point:**

1. Press the Menu Key repeatedly until "Calibrate 4-20 PRS Span?" is shown on the display.
2. Use the Up or Down key to select "Yes" and begin the calibration process. The display will now read "Apply 20mA then press OK".
3. Set the process calibrator to source a current of 20mA (100%).
4. Press the OK key and the message "Calibrating Wait..." will appear for several seconds followed by the message "Parameter Set" after the calibration has successfully completed.
5. Disconnect the process calibrator from the Pressure input and reconnect any wiring that was removed from it previously.

Disconnect the process calibrator's negative lead from the ground pin on the 4-20mA Input Card.

**RESETTING CALIBRATION DATA**

If you want to reset the calibration settings to default, use the "Cal Data" option at the end of menu 7.

**This process resets the following calibrations to defaults:**

- Calibration of the Thermocouples
- Calibration of the 4-20mA Output
- Calibration of the 4-20mA Input

1. Make sure that the system is stopped
2. Press the UP and Down Keys simultaneously to unlock the Calibration Menu (menu 7) which is normally hidden.
3. Press the Menu Key repeatedly until menu 7 is shown.
4. Press OK. If prompted, enter the L2 Password: ▲▼▲▲▼▲■
5. Press the Menu Key repeatedly until "Cal Data" is shown on the display
6. Use the Up or Down keys to select "Yes".
7. Press OK and the message "Parameter Saved" will show on the display briefly.
8. Press and hold the OK key for 3 seconds until the message "Password Logout" is displayed on the screen. The Calibration Menu is now hidden again.

**CALIBRATION (MENU 7)**

This menu is used to adjust the calibration of thermocouples, 4-20mA Output, and 4-20mA Expansion Card inputs. This menu is hidden by default.

MENU MAP	ON SCREEN	BRIEF DESCRIPTION	RANGE	DEFAULT SETTING	SECTION
Cal Process TC Zero	Cal Proc TC Zero?	Calibrate Process Thermocouple zero point by shorting the Input	N/A	N/A	
Cal High Temp TC Zero	Cal HiTemp TC Zero?	Calibrate High Temp Thermocouple zero point by shorting the Input	N/A	N/A	
Cal Aux TC Zero	Cal AUXTC Zero?	Calibrate Aux Thermocouple zero point by shorting the Input	N/A	N/A	
Cal Process TC Span	Cal Proc TC Span: xxC	Calibrate Process Thermocouple span point by applying a calibrated reference then adjust the on screen value	N/A	N/A	
Cal High Temp TC Span	Cal HiTemp TC Span: xxC	Calibrate High Temp Thermocouple span point by applying a calibrated reference then adjust the on screen value	N/A	N/A	
Cal Aux TC Span	Cal AUXTC Span: xxC	Calibrate Aux Thermocouple span point by applying a calibrated reference then adjust the on screen value	N/A	N/A	
Cal 4-20 Level Zero	Calibrate 4-20 LVL Zero?	Calibrate 4-20mA Level Input zero point by applying a calibrated 4mA reference	N/A	N/A	
Cal 4-20 Level Span	Calibrate 4-20 LVL Span?	Calibrate 4-20mA Level Input span point by applying a calibrated 20mA reference	N/A	N/A	
Cal 4-20 Pressure Zero	Calibrate 4-20 PRS Zero?	Calibrate 4-20mA Pressure Input zero point by applying a calibrated 4mA reference	N/A	N/A	
Cal 4-20 Pressure Span	Calibrate 4-20 PRS Span?	Calibrate 4-20mA Pressure Input span point by applying a calibrated 20mA reference	N/A	N/A	
Cal 4-20 Out Zero	Cal 4-20 Out Zero: x	Calibrate 4-20mA Output zero point by adjusting until a multimeter reads 4mA	N/A	N/A	
Cal 4-20 Out Span	Cal 4-20 Out Span: x	Calibrate 4-20mA Output zero point by adjusting until a multimeter reads 20mA	N/A	N/A	3.5.8
Display TC Zero Factors	Cal Factors Zero w x y z	Thermocouple zero point calibration factors for Debug	N/A	N/A	3.5.8
Display TC Span Factors	Cal Factors Span w x y z	Thermocouple span point calibration factors for Debug	N/A	N/A	3.5.8
Display 4-20 PRS Factors	4-20 PRS Factors Z=x S=y	4-20mA Pressure zero point and span point calibration factors for Debug	N/A	N/A	3.5.8
Display 4-20 LVL Factors	4-20 LVL Factors Z=x S=y	4-20mA Level zero point and span point calibration factors for Debug	N/A	N/A	3.5.8
Clear Cal	Clear All Cal Capital Data	Restore all calibration factors to 0'	Yes/No	No	3.5.8

## C | Resetting to Defaults

The system settings can all be reset to factory defaults by following these instructions:

1. Make sure that the system is stopped.
2. Navigate to the "Reset to Factory Defaults" menu item at the bottom of Menu 4.
3. Use the Arrow keys to change the setting to "Yes" and then press the OK key.
4. The system will display "Parameter Saved" and will then reboot.
5. After rebooting, the system will display the message "CONFIGURATION RESET TO DEFAULT" alternating with "Check Settings and Setpoints."
6. Press the OK key to acknowledge this warning.

This process only resets the user settings back to factory defaults and does not affect the calibration settings. To reset the calibration settings to defaults, refer to the [Field Calibration](#) section.

Note that older versions of firmware did reset both the user settings and the calibration settings to defaults. Also note that all settings are stored on the Door Card. If the Door Card is replaced for any reason, the settings will need to be re-entered and calibration may need to be performed.

**FOR ANY QUESTIONS PLEASE VISIT OR CALL US.**

[www.profireenergy.com](http://www.profireenergy.com) | 1.855.PRO.FIRE



[www.profireenergy.com](http://www.profireenergy.com)  
© 2015 PROFIRE