



PF2100 DOOR CARD REPLACEMENT GUIDE

WARNING

- Do not service or open enclosure unless power has been switched off and the area is known to be non-hazardous.
- No warranty is provided for the PF2100 replacement Door Card for damage resulting from improper application.
- Verify the firmware on the Terminal Card is compatible with the firmware on the replacement Door Card before purchasing.

OVERVIEW

This document contains step-by-step instructions to replace the Profire PF2100 Door Card.

COMPONENTS		INCLUDED WITH REPLACEMENT CARD
A	4 x Hex Nut	—
B	1 x PF2100 Door Card	✓
C	4 x Hex Standoff ^{Note 1}	Note 2
D	4 x Flat Washer	✓
E	1 x Door with Keypad	—
F	1 x Keypad Flat Flex Cable	—
G	1x Door Card to Terminal Card Ribbon Cable	—

Note 1 If the version of Door Card (B) being installed is lower than v1.7.50, ensure that 4 standoffs (C) are installed. If the version of Door Card (B) being installed is v1.7.50 or greater, ensure that 8 standoffs (C) are installed.

Note 2 Replacement Door Cards whose version is lower than v1.7.50 do not come with standoffs. Replacement Door Cards whose version is v1.7.50 or greater do come with standoffs.

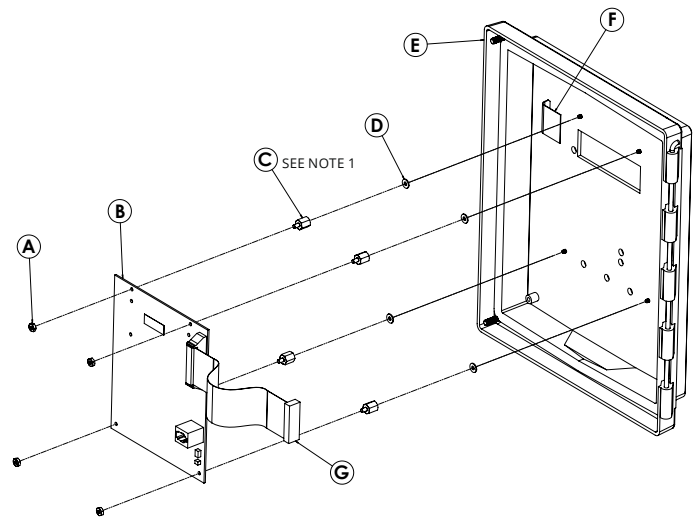

BEFORE YOU GO TO SITE

- ✓ Check that all components listed in the table are included in the box and that you have any others that you may need to complete the repair.
- ✓ If it is not possible to verify the firmware version on the existing Terminal Card is compatible with the replacement Door Card ahead of time, be prepared to replace both cards at the same time to ensure compatibility.

CHECKING COMPATIBILITY

- Referring to the charts below verify the firmware/hardware of the replacement Door Card is compatible with the firmware/hardware of the Terminal Card. Failure to do so may cause a safety issue, a BMS that will not run, or lead to erratic behavior. Unmatched firmware/hardware will also void warranty and product certification. The firmware version can be verified by pressing the Up and Down Keys simultaneously. The hardware/firmware version are also on labels as shown in the image below.

PF2100	
DC FIRMWARE	TC FIRMWARE
E1.8.217	E1.8.217
E1.8.206	E1.8.206
E1.8.116	E1.8.101
E1.8.115	E1.8.101
E1.8.005	E1.8.005
v1.6.3CE	v1.6.3B
v1.6.38	v1.6.36

PF2100C, PF2100F, & PF2100i	
DC FIRMWARE	TC FIRMWARE
C1.8.400	C1.8.400
F1.7.045	F1.7.045
F1.7.202	F1.7.202
i1.9.103	i1.9.101

PF2100 HARDWARE	
DC HARDWARE	TC HARDWARE
v1.6x	v1.6x
v1.7x	v1.7x or v2.4x

Note: x denotes any combination of numbers, letters, or a period.

FIRMWARE/HARDWARE VERSION LABELS ON DOOR CARD AND TERMINAL CARD

FIRMWARE ON PF2100 DISPLAY

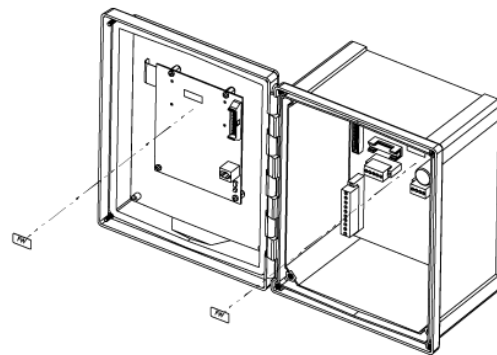

If the firmware/hardware is not compatible or you do not know the Terminal Card firmware/hardware versions, do one of the following:

- Consider replacing both the Door Card and Terminal Card at the same time to ensure that the firmware/hardware versions match.
 - Contact Profire Support to arrange for a card with older firmware loaded.
- Verify the Expansion Card Firmware is compatible. Expansion Cards will only function with Door Card Firmware versions as follows:
 - PF2100: FW v1.6.3CE and higher
 - PF2100C: All FW versions
 - PF2100F: All FW versions except 4-20 cards will only work with FW F1.7.044 and F1.7.045
 - PF2100i: All FW versions except 4-20 cards will only work with FW i1.9.103 (pressure input only)
 Best performance and features will be achieved with expansion cards running the latest firmware:
 - Modbus Card FW v4.4
 - Data Logging Card FW v5.1
 - 4-20 Input/Repeater Card FW v4.3

REMOVING THE OLD DOOR CARD

1. Make note of the old Door Card settings before uninstalling. The BMS settings are stored on the Door Card and will need to be re-entered if the Door Card is replaced. Refer to **PF2100 User Manual** (*scan QR code*) for info on Menus and Settings.
2. Disconnect the flat flex cable (F) connecting the old Door Card and the Keypad.
3. Disconnect the ribbon cable (G) connecting the old Door Card and the Terminal Card.
4. Remove the nuts (A) from the standoffs (C) holding down the old Door Card.
5. Ensure all connections have been disconnected before removing the old Door Card.
6. If returning the old Door Card to Profire for a warranty claim, please place the Door Card in the ESD shielded bag and packaging that came with the replacement card to prevent damage during shipping. Please obtain an RMA number and mark it on the packaging before returning any parts to Profire.



INSTALLING THE REPLACEMENT DOOR CARD

1. If a set of flat washers were not previously installed, install the flat washers (D) included in the package.
 - The washers may be installed on either side of the standoffs (C), but must be in place between the Door Card and door.
2. Tighten the standoffs (C) to **4in*lbs**. Different versions of Door Card use different numbers of standoffs:
 - If the version of Door Card (B) being installed is lower than v1.7.50, ensure that 4 standoffs (C) are installed.
 - If the version of Door Card (B) being installed is v1.7.50 or greater, ensure that 8 standoffs (C) are installed.
3. Gently install the replacement Door Card (B) onto the standoffs (C) in the correct orientation.
4. Secure the replacement Door Card (B) by using the 4 nuts (A) and tightening the nuts to **4in*lbs**.
5. Reconnect the flat flex cable (F) from the Keypad to the replacement Door Card (B).
6. Reconnect the ribbon cable (G) from the Terminal Card to the replacement Door Card (B).
7. Verify the firmware versions again by simultaneously pressing the Up and Down Keys.
8. Re-enter the settings from the old Door Card.
9. Follow the thermocouple calibration procedure outlined in the “calibrating the thermocouples” section of Appendix B in the **PF2100 User Manual** (*Scan QR code*).
10. Always perform the site-specific commissioning procedure after changing a card to ensure that the system is operating correctly.