



4-20mA REPEATER CARD USER MANUAL v1.3

EXPANSION CARD

Table of Contents

1	Overview	1
1.1	System Requirements	1
1.2	Comparison to 4-20mA Input Card	1
2	Level Output	2
2.1	Output Type	2
2.2	Output Specifications	2
2.3	Output Wiring	3
3	Level Offset Compensation	4
3.1	Background	4
3.2	Installation Considerations	5
3.2.1	Level Transmitters With Built-In Compensation	5
3.2.2	Effect on Level Output	5
3.2.3	PF2100 System Requirements	5
3.3	Software Configuration	5

1 Overview

The Profire 4-20mA Repeater Card provides PF2100 systems with two 4-20mA inputs for use with level and pressure transmitters, as well as a 4-20mA output which mirrors the input 4-20mA level signal. This allows a 4-20mA level transmitter to communicate with a PF2100 as well as another device with 4-20mA inputs (such as a PLC) without the use of additional hardware.

1.1 System Requirements

The 4-20mA Repeater Card is supported by PF2100 systems that meet the following minimum requirements:

	Minimum version	Minimum version for Level Offset
Door Card Hardware	v1.6	
Terminal Card Hardware	v1.6	
Door Card Firmware	E1.8.005	E1.8.202
Terminal Card Firmware	E1.8.005	E1.8.200

A Modbus Expansion Card installed with a 4-20mA Repeater Card on the same PF2100 must have v4.1 or newer firmware in order for the system to operate correctly.

1.2 Comparison to 4-20mA Input Card

The 4-20mA Repeater Card is behaviorally identical to the Profire 4-20mA Input Card with the exception of the additional 4-20mA level output. Therefore, if an existing 4-20mA Input Card is replaced with a 4-20mA Repeater Card, there will be no change to system behaviour as long as both expansion cards have the same firmware installed.

Because of the similarity between the 4-20mA expansion cards, this document **does not** cover the basic behaviour of a PF2100 in response to the 4-20mA inputs of the Repeater Card. The hardware specifications/requirements for the inputs/outputs available on the 4-20mA Input Card are also not covered in this document. For this information, please refer to the *4-20mA Input Card Instruction Manual*, available at www.profireenergy.com.

This document covers the 4-20mA level output as well as the level offset feature available to newer PF2100 systems.

2 Level Output

2.1 Output Type

For its level output, the 4-20mA Repeater Card acts as a **self-powered** 4-20mA transmitter. The transmitter is powered by the PF2100, so the 4-20mA receiver does not need to provide power to the 4-20mA Repeater Card in order to receive a signal. This also means that the maximum voltage available to the output to drive the 4-20mA signal is the same as the PF2100 system voltage (12V or 24V).

2.2 Output Specifications

Because the 4-20mA Repeater Card has an active 4-20mA output, there are no power supply requirements for the 4-20mA receiver it is connected to, so all 4-20mA inputs should be compatible with the level output. The level output's electrical specifications are shown in the table below:

Maximum Loop Voltage	Profire system voltage (12V or 24V)
Output Impedance	125Ω to 500 Ω

2.3 Output Wiring

The following diagrams show two possible wiring configurations for the 4-20mA level output. The difference between the two configurations only depends on the type of 4-20mA level transmitter used. Refer to the *4-20mA Input Card Instruction Manual* for details regarding the level transmitter input on the Repeater Card. The PLC wiring shown is appropriate because the 4-20mA Repeater Card acts as a self-powered transmitter. **If the Repeater Card level output is wired as a loop-powered transmitter it will not work.**

Using Passive 4-20mA Level Transmitter

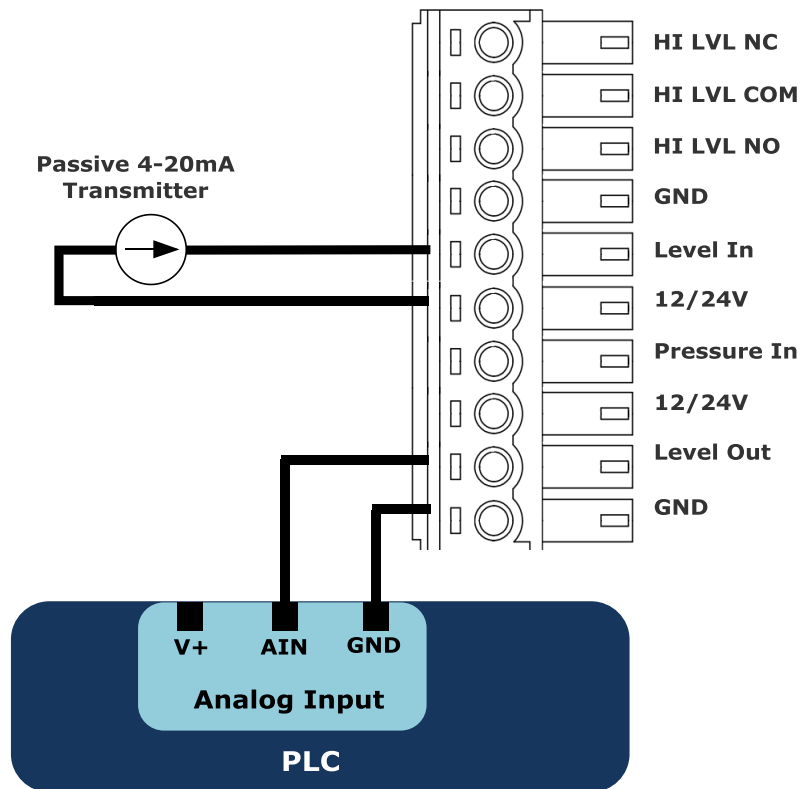

Using Active 4-20mA Level Transmitter

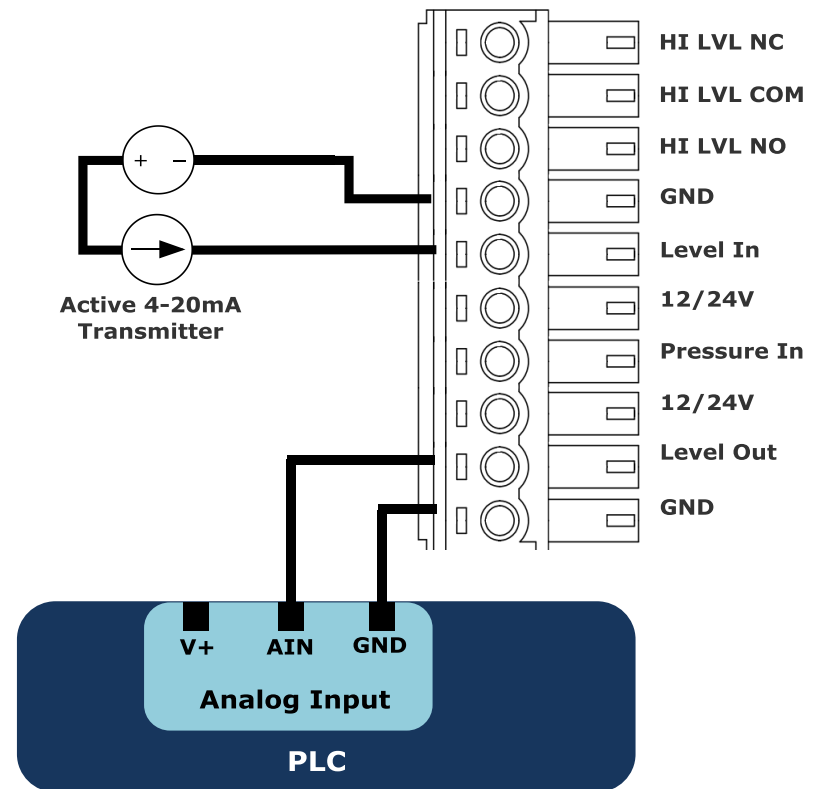

3 Level Offset Compensation

3.1 Background

In certain level measurement applications, it is not possible to place a level sensor at the bottom of a vessel, due to the possibility of accumulation of sand or other solids.

When the level sensor is not at the bottom of the vessel, the level measurement does not actually represent the level of the vessel, since there is an offset between the bottom of the vessel and the bottom of the sensor.

Profire PF2100 systems with Door Card firmware versions later than E1.8.202 and Terminal Card firmware versions later than E1.8.200 provide optional compensation for this offset. If a user enters the volume between the lowest point of the sensor and the bottom of the vessel, the PF2100 will adjust its display/control to compensate for the difference.

The figure to the right illustrates this idea. The level transmitter will read 0m^3 (and output 4mA) because the fluid level is below the sensor. With no level compensation, a PF2100 will display the level transmitter's 4mA signal as 0m^3 with a range of $0\text{-}70\text{m}^3$ for the vessel. With level compensation, the PF2100 can interpret 4mA as 30m^3 with the proper range of $0\text{-}100\text{m}^3$ for the vessel. Note that $0\text{-}30\text{m}^3$ measurements cannot be encoded by the $4\text{-}20\text{mA}$ signal since they are not actually measured by the level sensor.

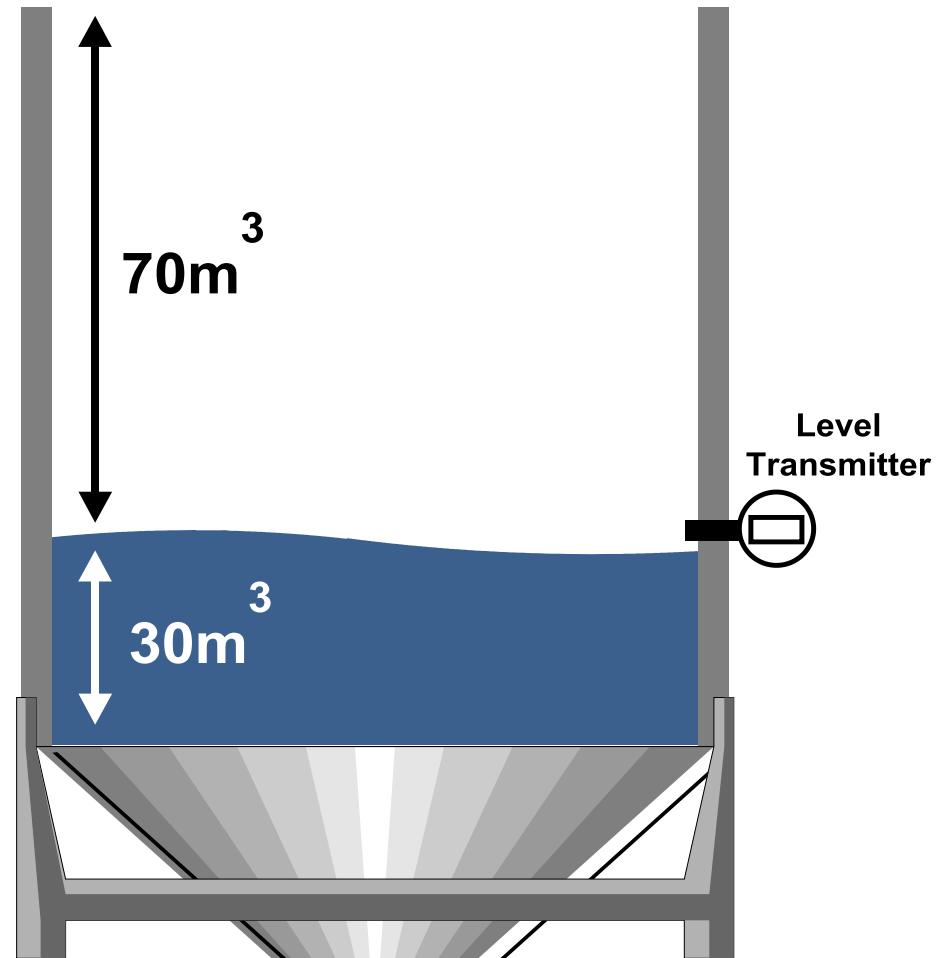

3.2 Installation Considerations

3.2.1 LEVEL TRANSMITTERS WITH BUILT-IN COMPENSATION

Certain transmitters (e.g., Rosemount 2088) allow for level offset compensation independent of the PF2100. This is accomplished by changing the span of the transmitter's 4-20mA signal.

As an example, if a vessel has a level sensor that only measures its top half and an operator enters the offset, the transmitter will encode the full range of the level sensor as a 12-20mA signal. This allows for a PF2100 without level offset compensation to properly display the level in the vessel. Care must be taken to ensure that the PF2100 Level Low and Level High Setpoints are not set to be within the range that the transmitter cannot encode.

Many transmitters do not support this type of offset compensation, so the compensation provided by the PF2100 can be used in these cases. The PF2100 level offset compensation allows the transmitter to use the entire 4-20mA span which improves the resolution of the level measurement.

3.2.2 EFFECT ON LEVEL OUTPUT

It is important to note that the 4-20mA Repeater Card will never adjust its 4-20mA level output signal due to level offset compensation. The 4-20mA level output signal will always directly mirror the 4-20mA level input signal (i.e., mA input = mA output).

3.2.3 PF2100 SYSTEM REQUIREMENTS

As mentioned, the level offset feature is only available on Profire PF2100 systems with the following firmware versions:

Door Card Firmware	E1.8.202 or later
Terminal Card Firmware	E1.8.200 or later

3.3 Software Configuration

Level offset compensation can be enabled on the PF2100 using the following procedure:

1. Navigate to the "6 – Expansion Cards" menu
2. Set the "4-20 LVL Range" entry to the **volume of the entire vessel**. This setting should not have any compensation for the positioning of the level sensor.
3. Set the "Level Zero Offset" entry to the difference between the bottom of the level sensor and the bottom of the vessel.

After these steps have been performed, the PF2100 will automatically compensate the 4-20mA reading for its level offset.

The PF2100 will now apply compensation to the following:

- Level reading on user interface
- Low level shutdowns
- High level contact behaviour
- Level reading via Modbus Expansion Card

Information on navigating the PF2100 menus can be found in the *PF2100 User Manual* available at www.profireenergy.com.